

■ AC Power
For Business-Critical Continuity™

Liebert® STS2/PDU™

User Manual—250A-800A, Three-Phase, 60 Hz



CONTACTING LIEBERT FOR SUPPORT

To contact Liebert Global Services for information or repair service in the United States, call 1-800-LIEBERT (1-800-543-2378). Liebert Global Services offers a complete range of start-up services, repair services, preventive maintenance plans and service contracts.

For repair or maintenance service outside the 48 contiguous United States, contact Liebert Global Services, if available in your area. For areas not covered by Liebert Global Services, the authorized distributor is responsible for providing qualified, factory-authorized service.

For Liebert Global Services to assist you promptly, please have the following information available:

Part Numbers:

Serial Numbers:

Rating:

Date

Purchased:

Date Installed:

Location:

Input Voltage/

Frequency:

Output Voltage/

Frequency:

TABLE OF CONTENTS

CONTACTING LIEBERT FOR SUPPORT	INSIDE FRONT COVER
IMPORTANT SAFETY INSTRUCTIONS	1
1.0 UNPACKING AND INSPECTIONS	3
1.1 External Inspections	3
1.2 Unloading and Handling	3
1.2.1 Handling Considerations	4
1.2.2 Unit Preparation	4
1.3 Internal Inspection	4
2.0 LOCATION CONSIDERATIONS	5
2.1 Recommended Minimum Service Clearances	5
2.2 Heat Output	5
2.3 Operating Environment	5
2.4 Altitude	6
3.0 LOCATING THE LIEBERT STS2/PDU	7
3.1 Anchoring the Unit to the Floor	7
3.2 Leveling of the 250A Only Liebert STS2/PDU Without Anchoring	7
4.0 POWER AND CONTROL WIRING	8
4.1 Input and Output Power Connections	8
4.2 System Grounding	11
4.3 Control Wiring Connections	11
4.4 Remote Source Selection Wiring	11
4.5 Power Supply	12
5.0 OUTPUT POWER WIRING	13
5.1 Customer Connections	13
6.0 OPTIONS	14
6.1 Programmable Relay Board	14
6.2 Input Contact Isolator Board	14
6.3 Comms Board	15
6.4 Liebert IntelliSlot [®] Web/485 Card With Adapter	15
6.5 Remote Source Selection	15
6.6 Key Lockout Switch	15
6.7 Static Switch Redundant Output Breaker	16
6.8 Inline Panelboards	16
6.9 I-Line Panelboards	16
6.10 Subfeed Breakers	16
6.11 K-Factor Transformers	16
6.12 Surge Suppression System	16
7.0 INSTALLATION DRAWINGS	17

8.0	INTRODUCTION TO LIEBERT STS2/PDU OPERATION	68
8.1	System Description.	68
8.1.1	Redundancy	68
8.1.2	Reliability and Agency Requirements	69
8.1.3	Factory Backup and Service Assistance	69
8.2	Modes of Operation.	69
8.2.1	Normal (Preferred Source)	69
8.2.2	Transfer	70
8.2.3	Transfer Inhibit	70
8.2.4	Bypass.	70
8.3	Operator Controls.	70
9.0	THEORY OF OPERATION	71
9.1	General Description	71
9.1.1	Liebert Static Transfer Switch 2/Power Distribution Unit	71
9.1.2	Source Transfer	71
9.1.3	Automatic Transfer/Retransfer.	71
9.1.4	Emergency Transfer	72
9.1.5	Load Current Transfer Inhibit	72
9.1.6	SCR Failure	72
9.1.7	On/Off Sequence.	72
9.2	Detailed Component Description.	72
9.2.1	Controls	72
9.2.2	Circuit Breakers and Non-Automatic Circuit Breakers	73
9.2.3	SCRs	73
9.2.4	Logic Modules.	73
9.2.5	Audible Alarm	73
9.2.6	RS-232 Port	73
10.0	OPERATING INSTRUCTIONS	74
10.1	Normal System Turn-On	74
10.2	Manual Transfer / Preferred Source Selection	76
10.3	Enabling Remote Source Selection	77
10.4	Maintenance Bypass	77
10.4.1	Bypass Procedures for Source 1	78
10.4.2	Bypass Procedures for Source 2	79
10.5	Normal System Shutdown	80
10.5.1	Shutdown in Static Transfer Switch Mode.	80
10.5.2	Shutdown in Maintenance Bypass Mode	80
11.0	ALARMS AND FAULTS.	81
11.1	Event Mask.	81
11.2	Event and History Logs	82
11.2.1	Event Log	82
11.2.2	History Log.	83
11.3	Alarm Notes	83
11.4	List of Messages	83

12.0	COMMUNICATION INTERFACES	86
12.1	Using the RS-232 Port	87
12.1.1	Connecting and Using a Terminal	87
12.1.2	Configuring the Liebert STS2/PDU via the Terminal	88
12.1.3	Setting Bitpacked Options With the Terminal	91
12.1.4	Setting Event Masks with the Terminal	93
13.0	TOUCH SCREEN DISPLAY	95
13.1	Display Overview	95
13.2	Menu Overview	96
13.2.1	Security	97
13.3	Mimic Display	98
13.4	Event Controls	98
13.5	Event Display	98
13.6	Menu Bar	98
13.7	Configuration Menu	98
13.7.1	Logs	112
13.7.2	Source Transfers	113
13.7.3	Startup Procedure	113
13.7.4	Bypass Procedure	113
13.7.5	Help	113
13.7.6	Logo	113
13.8	Cleaning the LCD Touch Screen	113
14.0	SPECIFICATIONS	114
14.1	System Configuration	114
14.1.1	Frequency	114
14.1.2	Input Voltage	114
14.1.3	Output Voltage	114
14.1.4	System Current Ratings	114
14.1.5	Grounding	114
14.1.6	Electrical Requirements	115
14.1.7	Surge Suppression	115
14.1.8	Response Time	115
14.1.9	Environmental Requirements	115
14.2	System Components	115
14.2.1	Frame and Enclosure	116
14.2.2	Caster and Leveling - 250A only	116
14.2.3	Cooling	116
14.2.4	Access	117
14.2.5	Circuit Breakers	117
14.2.6	Cable Entrance	117
14.2.7	Doors	117
14.2.8	Color Graphical Display	117
14.2.9	RS-232 Port	118
14.2.10	Terminal Port Connections	118
14.2.11	RS-232 Interface Parameters	119
14.2.12	Maintenance Bypass	119
14.2.13	Fuseless Design	119
14.2.14	Options	119

15.0	EVENT MESSAGE HELP TEXT	120
16.0	MAINTENANCE	143
16.1	Proper Tightening of Nuts and Bolts	143
16.2	Testing the Liebert STS2/PDU	143
16.3	Changing the Air Filter	143
17.0	CUSTOMER SETTINGS.	144
17.1	Programmable Relay Board Settings	144
17.2	Input Contact Isolator Settings	146

FIGURES

Figure 1	Recommended derating for high altitude operation	6
Figure 2	Maximum ambient temperature for full load operation at higher altitudes.	6
Figure 3	Typical Liebert STS2/PDU, one-line diagram	9
Figure 4	Typical Liebert STS2/PDU, one-line diagram, with dual static switch output circuit breakers (not available on 250A units)	9
Figure 5	Typical Liebert STS2/PDU, one-line diagram, with inline distribution, dual static switch output circuit breakers.	10
Figure 6	Typical Liebert STS2/PDU, one-line diagram, with I-Line distribution, dual static switch output circuit breakers.	10
Figure 7	Outline drawing, 250A Liebert STS2/PDU	17
Figure 8	Outline drawing, 250A Liebert STS2/PDU with right side I-Line distribution	18
Figure 9	Outline drawing, 250A Liebert STS2/PDU with right side inline distribution.	19
Figure 10	Outline drawing, 250A Liebert STS2/PDU with left side I-Line distribution.	20
Figure 11	Outline drawing, 250A Liebert STS2/PDU with left side Inline distribution	21
Figure 12	Outline drawing, 400-600A Liebert STS2/PDU with right side inline distribution.	22
Figure 13	Outline drawing, 400-600A Liebert STS2/PDU with right side output breaker or I-Line distribution	23
Figure 14	Outline drawing, 400-600A Liebert STS2/PDU with left side inline distribution	24
Figure 15	Outline drawing, 400-600A Liebert STS2/PDU with left side output breaker or I-Line distribution	25
Figure 16	Outline drawing, 800A Liebert STS2/PDU with right side output breaker or I-Line distribution	26
Figure 17	Outline drawing, 800A Liebert STS2/PDU with right side inline distribution.	27
Figure 18	Outline drawing, 800A Liebert STS2/PDU with left side output breaker or I-Line distribution	28
Figure 19	Outline drawing, 800A Liebert STS2/PDU with left side inline distribution	29
Figure 20	Outline drawing, 250A Liebert STS2/PDU with key lockout switch option	30
Figure 21	Outline drawing, 400-600A Liebert STS2/PDU, inline distribution, right side with key lockout switch option	31
Figure 22	Outline drawing, 800A Liebert STS2/PDU, inline distribution, right side with key lockout switch option.	32
Figure 23	Electrical field connections, 250A Liebert STS2/PDU input/output with CB8	33
Figure 24	Electrical field connections, 250A Liebert STS2/PDU input with CB3	34
Figure 25	Electrical field connections, 250A Liebert STS2/PDU input with CB3 & CB3A	35
Figure 26	Electrical field connections, 400-600A Liebert STS2/PDU input with CB3	36
Figure 27	Electrical field connections, 400-600A Liebert STS2/PDU input with CB3 and CB3A	37
Figure 28	Electrical field connections, 800A Liebert STS2/PDU input with CB3	38
Figure 29	Electrical field connections, 800A Liebert STS2/PDU input with CB3 and CB3A	39
Figure 30	Electrical field connections, 250A Liebert STS2/PDU output with inline panelboards	40
Figure 31	Electrical field connections, 400-800A Liebert STS2/PDU output with inline panelboards	41

Figure 32	Electrical field connections, Liebert STS2/PDU output with I-Line panelboard	42
Figure 33	Electrical field connections, 400-600A Liebert STS2/PDU with right side output breaker	43
Figure 34	Electrical field connections, 400-600A Liebert STS2/PDU with left side output breaker	44
Figure 35	Electrical field connections, 800A Liebert STS2/PDU with right side output breaker	45
Figure 36	Electrical field connections, 8600A Liebert STS2/PDU with left side output breaker	46
Figure 37	Electrical field connections, 800A Liebert STS2/PDU interconnect wiring.	47
Figure 38	Electrical field connections, 800A Liebert STS2/PDU interconnect wiring, breaker section	48
Figure 39	Electrical field connections, 800A Liebert STS2/PDU interconnect wiring, STS section	49
Figure 40	Electrical field connections, 800A Liebert STS2/PDU interconnect wiring, left side distribution cabinet	50
Figure 41	Electrical field connections, 800A Liebert STS2/PDU interconnect wiring, left side one-line	51
Figure 42	Electrical field connections, 800A Liebert STS2/PDU interconnect wiring, left side one-line with CB3A	52
Figure 43	Electrical field connections, 800A Liebert STS2/PDU interconnect wiring, right side one-line	53
Figure 44	Electrical field connections, 800A Liebert STS2/PDU interconnect wiring, right side one-line with CB3A	54
Figure 45	Control wiring, 800A Liebert STS2/PDU, left side distribution.	55
Figure 46	Control wiring, 800A Liebert STS2/PDU, right side distribution	56
Figure 47	Control connection location, 250A Liebert STS2/PDU	57
Figure 48	Control connection location, 400-800A Liebert STS2/PDU	58
Figure 49	Control location drawing conduit box, top entry, 400-600A Liebert STS2/PDU	59
Figure 50	Control wiring for the programmable relay board option.	60
Figure 51	Control wiring for the input contact isolator board option.	61
Figure 52	Control wiring for comms board.	62
Figure 53	Control wiring for the Liebert IntelliSlot Web/485 Card With Adapter option.	63
Figure 54	Control wiring for the RS-232 Port	64
Figure 55	Control wiring for remote source selection option.	65
Figure 56	Color LCD touch screen display	66
Figure 57	Liebert STS2/PDU touch screen display	70
Figure 58	Liebert STS2/PDU touch screen display	74
Figure 59	Source Transfer screen	76
Figure 60	Gate board viewing slot locations.	77
Figure 61	Liebert STS2/PDU Touch Screen Display	95
Figure 62	Menus	96
Figure 63	Keyboard and keypad displays.	96
Figure 64	Key lockout switch	97
Figure 65	Event Mask dialog box	99
Figure 66	User settings dialog box	100
Figure 67	Source setpoints	101
Figure 68	PDU setpoints	103
Figure 69	Comm options dialog box	104
Figure 70	Modem dialog box	105
Figure 71	Input Contact Isolator dialog box.	107
Figure 72	Programmable relay board dialog box.	109
Figure 73	System options	110
Figure 74	PDU options button	111
Figure 75	Event log	112
Figure 76	History log	112

TABLES

Table 1	Shipping weights (typical)	4
Table 2	Heat output	5
Table 3	Input/output conduit plate specifications	10
Table 4	Remote source selection terminal block.	11
Table 5	Terminal block 1 and terminal block 2 wire connections	12
Table 6	Distribution configurations	13
Table 7	Programmable relay board pinout	14
Table 8	Input circuit breaker schedule, 250-800A	67
Table 9	Output circuit breaker schedule, 250-800A.	67
Table 10	Non-automatic breaker schedule, 250-800A	67
Table 11	Event messages	84
Table 12	Terminal commands	87
Table 13	Value types	89
Table 14	Group settings and values	90
Table 15	Binary-hexadecimal conversions	92
Table 16	Setpoint parameters	101
Table 17	PDU setpoints	103
Table 18	Standard settings for programmable relays	108
Table 19	Input voltage	114
Table 20	Output voltage.	114
Table 21	System current ratings	114
Table 22	Electrical requirements	115
Table 23	Unit short circuit withstand capability	115
Table 24	Frame sizes	116
Table 25	MTA plug pinout	118
Table 26	DB9 pinout	118
Table 27	RS-232 settings	119
Table 28	Torque tightening	143
Table 29	Branch circuit breakers	143
Table 30	Programmable relay board settings record	144
Table 31	Input contact isolator settings record	146

IMPORTANT SAFETY INSTRUCTIONS

SAVE THESE INSTRUCTIONS

This manual contains important instructions that should be followed during the installation and maintenance of the Liebert Static Transfer Switch 2/Power Distribution Unit (Liebert STS2/PDU).

Read this manual thoroughly, paying special attention to the sections that apply to your installation, before working with the Liebert STS2/PDU. Retain this manual for use by installing personnel.

Refer to **1.2.1 - Handling Considerations** before attempting to move the unit.



WARNING

Risk of electric shock. Can cause injury or death.

Before proceeding with installation, read all instructions, verify that all the parts are included and check the nameplate to be sure the voltage matches available utility power.

This unit is supplied by more than one power source. The unit contains hazardous voltages if any of the input sources are on, even when the unit is in bypass. To isolate the unit, turn off and lock out all input power sources.

Verify that all input power sources are de-energized and locked out before making connections inside unit.

Lethal voltages exist inside the unit during normal operation. Only qualified service personnel should perform maintenance on the Liebert STS2/PDU.

Installation and operation must comply with all national and local laws and regulations.



WARNING

Risk of electric shock. Can cause injury or death.

Under typical operation and with all Liebert STS2/PDU doors closed, only normal safety precautions are necessary. The area around the Liebert STS2/PDU should be kept free of puddles of water, excessive moisture, flammable liquids, gases, corrosive substances and debris.

Only properly trained personnel wearing appropriate safety headgear, gloves, shoes and glasses should perform maintenance on the Liebert STS2/PDU. When performing maintenance on any part of the equipment under power, service personnel and test equipment should be located on rubber mats. Service personnel should wear insulating shoes for isolation from direct contact with the floor.

One person should never work alone, even if all power is disconnected from the equipment. A second person should be standing by to assist and summon help in case of an accident.

NOTICE

Risk of damage from improper installation.

The input sources to the Liebert STS2/PDU must be grounded-wye sources. Input sources other than solidly grounded-wye sources may cause damage to the switch.

Liebert neither recommends nor knowingly sells this product for use with life support or other FDA-designated “critical” devices.

The Liebert STS2/PDU is suitable for indoor use only.

The unit is designed to operate from solidly grounded AC power sources only. Provide input over-current protection in accordance with the unit ratings. Wire and ground the unit according to national and local electrical safety codes. All wiring should be installed by a properly trained and qualified electrician.

A thorough equipment inspection and supervised startup by qualified service personnel are strongly recommended at these times:

1. Before unit is placed into service for the first time
2. After equipment relocation, and
3. After the unit has been de-energized for an extended period.



WARNING

Risk of heavy unit falling over. Can cause equipment damage, injury or death.

Locate the center of gravity symbols and determine the unit's weight  before handling the cabinet.

Read all instructions before attempting to move the unit, lift it, remove packaging or prepare the unit for installation.

NOTICE

This unit complies with the limits for a Class A digital device, pursuant to Part 15 Subpart J of the FCC rules and EN550022. These limits provide reasonable protection against harmful interference in a commercial environment. This unit generates, uses and radiates radio frequency energy and, if not installed and used in accordance with this instruction manual, may cause harmful interference to radio communications. Operating this unit in a residential area may cause harmful interference that the user must correct at his own expense.

1.0 UNPACKING AND INSPECTIONS



NOTE

Read the entire manual before beginning to install the Liebert STS2/PDU. Upon delivery of the Liebert STS2/PDU, the installer should perform the following steps to ensure a high-quality installation.

A high-quality installation begins on the receiving dock. The Liebert STS2/PDU and its packaging should be inspected when the unit is delivered. If the packaging is not damaged, unpack the unit and conducting internal inspection before beginning the installation process. This section discusses inspecting and unpacking the Liebert STS2/PDU.

1.1 External Inspections

1. While the Liebert STS2/PDU is still on the truck, inspect the equipment and shipping container(s) for any signs of damage or mishandling. Do not attempt to install the system if damage is apparent.
2. Upon receipt and before unpacking, inspect the shipping crate for damage or mishandling. Check the Shock-Watch™ indicator.
 - If the indicator is red, note the condition on shipper's receipt and check for concealed damage.
 - If any shipping damage is observed, file a damage claim with the shipper within 24 hours and contact your local Liebert representative or Emerson Network Power Liebert Services at 1-800-543-2378 to inform them of the damage claim and the condition of the equipment.
3. Locate the bag containing the keys for the front access door. The bag is attached to the cabinet.
4. Compare the contents of the shipment with the bill of lading. Report any missing items to the carrier and to Liebert Services immediately.
5. Check the nameplate on the cabinets to verify that the model numbers correspond with the one specified. Record the model numbers and serial numbers in the front of this installation manual. A record of this information is necessary should servicing be required.
6. If unit is to be stored before installation, it is recommended to store the unit in a dry environment with temperatures in the range of -40 to 176°F (-40 to 80°C). Use original packing materials or other suitable means to keep the unit clean. When opening the shipping crate, use care not to puncture the container with sharp objects.

1.2 Unloading and Handling



WARNING

Risk of heavy unit falling over. Can cause equipment damage, injury or death.

Locate the center of gravity symbols and determine the unit's weight  before handling the cabinet.

Do not exceed a 15-degree tilt with the forklift. Read all instructions before attempting to move the unit, lift it, remove packaging or prepare the unit for installation.

NOTICE

When moving the unit by forklift, lift the unit from the rear so as to protect the front panel. Also, if moving the unit by forklift or pallet jack after it has been removed from the pallet, be aware of the location of the casters and leveling feet (if the unit is so equipped) so as not to damage them.

Most Liebert STS2/PDU models are contained in one cabinet. The 800 amp units are contained in two cabinets that shipped on two pallets and connected together in the field.

The unit can be moved by forklift or pallet jack. However, because the weight distribution in the cabinet is uneven, use extreme care during handling and transporting.

See **1.2.2 - Unit Preparation** for instructions on removing the Liebert STS2/PDU from the pallet.

1.2.1 Handling Considerations

The Liebert STS2/PDU is bolted to a wood shipping pallet to allow handling by forklift or a pallet jack.



WARNING

Risk of heavy unit falling over. Can cause equipment damage, injury or death.

Exercise extreme care when handling Liebert STS2/PDU cabinets to avoid equipment damage or injury to personnel.

The cabinet can be safely tilted 15 degrees in any direction by forklift. If moving the unit up a ramp on its casters (if the unit is so equipped) or a pallet jack, ensure that the incline does not exceed 15 degrees.

Locate the center of gravity symbols and determine the unit's weight  before handling the cabinet.

Check the unit size and weight. Refer to the cabinet drawings furnished with the unit for size and weight. Typical cabinet dimensions are shown in **Figures 7** through **22**. Typical unit crated weights are:

Table 1 Shipping weights (typical)

Model	Weight - lb. (kg)
250A	3730 lb. (1692 kg)
400A	4900 lb. (2132 kg)
600A	5580 lb. (2531 kg)
800A Module A*	4052 lb. (1838 kg)
800A Module B*	4595 lb. (2084 kg)

*800A ships on two separate pallets

Plan the route. Review the route over which the unit will be transported to its installation location to ensure that all passages are large enough to accommodate the unit and support the weight.

Check for any non-negotiable corners or offsets in hallways. Before moving the unit to the intended location, review **2.0 - Location Considerations**.

1.2.2 Unit Preparation

The unit can be removed from the pallet before it is moved to its location.

Complete the following steps to properly remove the Liebert STS2/PDU from the shipping pallet:

1. Set the pallet in a level area with enough room to maneuver and remove the unit.
2. Remove the bolts holding the unit to the shipping pallet (located in the base of the unit).
3. Remove the shipping blocks from under the frame of the unit.
4. Use a forklift to raise the unit off the pallet and onto the floor. On the 250A unit ensure that the forklift is clear of the unit's casters and leveling feet. Lift the unit from the rear.
5. Conduct an internal inspection of the unit. See the list in **1.3 - Internal Inspection**.

1.3 Internal Inspection

After the Liebert STS2/PDU has been unpacked, conduct an internal inspection:

1. Verify that all items have been received.
2. If spare parts were ordered, verify their arrival.
3. After the Liebert STS2/PDU has been removed from the pallet, open the door and remove cabinet panels to check for shipping damage to internal components.
4. Check for loose connections or unsecured components in the cabinet(s).
5. Check for any unsafe condition that may be a potential safety hazard.

After the Liebert STS2/PDU has been inspected and no problems are found, the unit can be moved to its installation location. If using a forklift, remember to lift the unit from the rear.

2.0 LOCATION CONSIDERATIONS

The Liebert STS2/PDU should be placed in a clean, cool and dry location. The 250A unit without an output cabinet requires only front access for installation and maintenance. Both front and side access are required for installation and maintenance of 400-800A units and 250A units with output cabinet. The output cabinet comes factory-installed or either the right or left side, depending on how it was ordered. It cannot be moved from one side to the other in the field.

Adequate space is required above the unit for conduit (if configured as such) and cooling air flow. This section provides specific information for these considerations.

The unit is designed with top and bottom cable terminations to allow maximum flexibility in its installation. Units with output inline panelboards are bottom exit only. If bottom cable entry and exit is used, sufficient cable bending space must be provided by a raised floor or a floor stand.

For dimensions of each unit, see **Figures 7** through **22**. If your unit is equipped with an optional key lockout switch, see **Figures 13** through **21** for the location of that switch.

2.1 Recommended Minimum Service Clearances

The recommended service clearances are at the front and side, if equipped with output cabinet. The minimum service clearance required by the National Electrical Code (NEC) Article 110-26 is 36 in. (91cm) for units with voltages up to 150V to ground and 42 in. (107cm) for units with voltages over 150V to ground. Clearance of at least 18 in. (46cm) is required above the unit for cooling air flow.

2.2 Heat Output

The unit produces minimal heat during normal operation.

Table 2 Heat output

Switch Size	Heat Output BTU/Hr (kW)
250A	12,590 (3.69)
400A	20,140 (5.90)
600A	30,200 (8.85)
800A	40,270 (11.80)

2.3 Operating Environment

The unit is designed to be installed indoors where the ambient air temperature is in the range of 32° to 104°F (0°C - 40°C) with a relative humidity of 0% to 95% non-condensing, up to an altitude of 4000 feet (1200 meters).

2.4 Altitude

The standard units are designed for full load operation up to 4000 feet (1200m) above sea level. See **Figure 1** for recommended deratings for altitudes greater than 4000 feet (1200m).

Figure 1 Recommended derating for high altitude operation

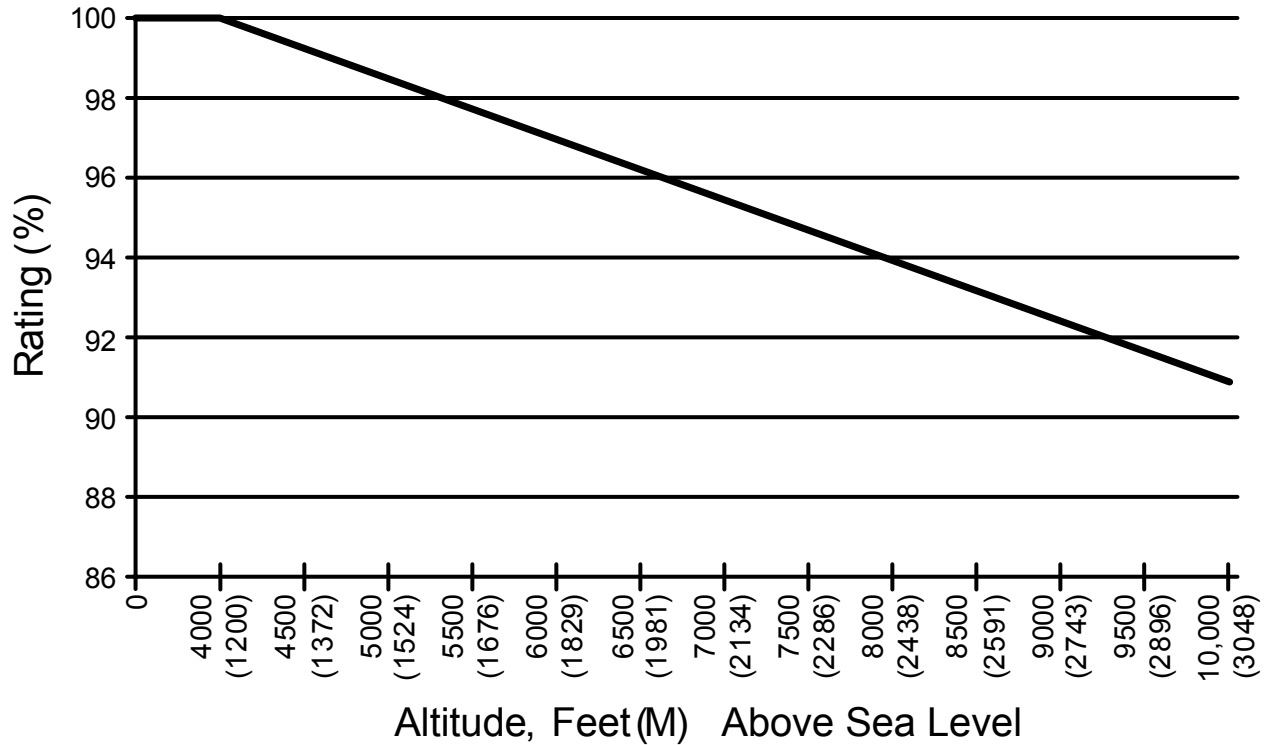

Operation at full load at a higher altitude can be accommodated in ambient temperatures less than 104°F (40°C) ambient. **Figure 2** shows the maximum allowable ambient temperature for full load operation at altitudes above 4000 feet (1200m).

Figure 2 Maximum ambient temperature for full load operation at higher altitudes

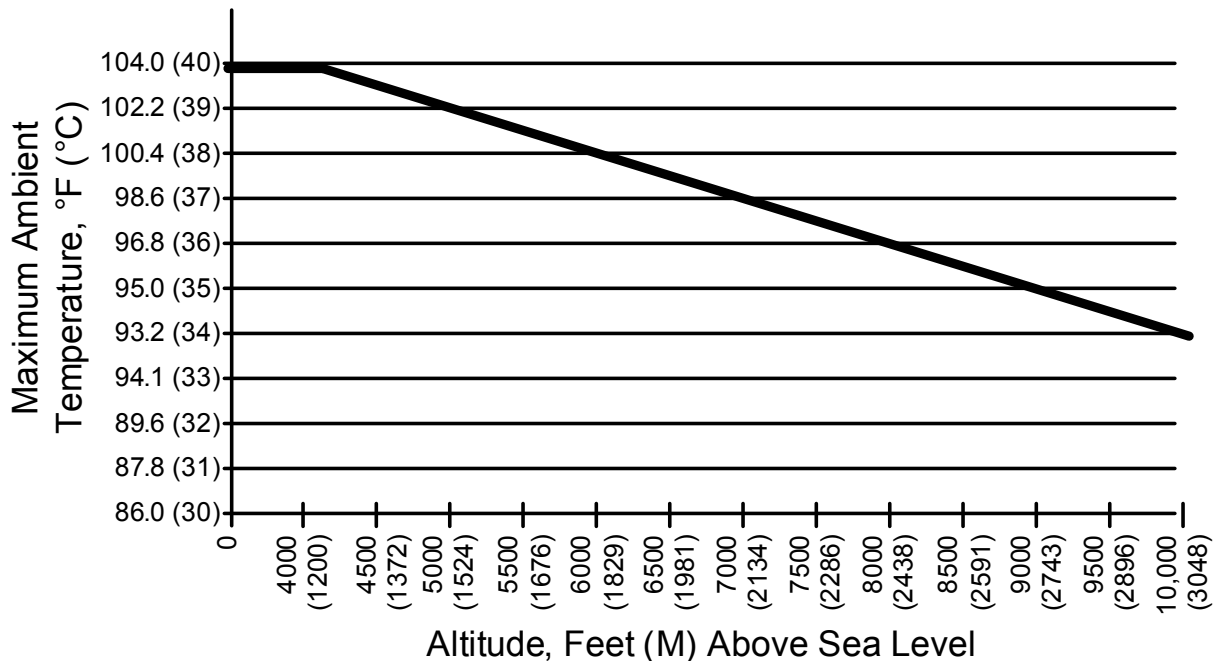

3.0 LOCATING THE LIEBERT STS2/PDU

This section provides instructions for leveling the Liebert STS2/PDU and anchoring the unit to the floor, should that be required.

3.1 Anchoring the Unit to the Floor

The Liebert STS2/PDU can be anchored to the concrete floor to ensure stability for the unit in the event of seismic activity.

3.2 Leveling of the 250A Only Liebert STS2/PDU Without Anchoring

The 250A Liebert STS2/PDU is furnished with casters and leveling feet. After final positioning of the unit, adjust the leveling feet located in each corner of the frame base to level and stabilize the unit.

For leveling feet details, see **Figures 7** through **11**.

4.0 POWER AND CONTROL WIRING



WARNING

Risk of electric shock. Can cause injury or death.

This unit is supplied by more than one power source. The unit contains hazardous voltages if any of the input sources are on, even when the unit is in bypass. To isolate the unit, turn off and lock out all input power sources.

Verify that all input power sources are de-energized and locked out before making connections inside unit.

Lethal voltages exist inside the unit during normal operation. Only qualified service personnel should perform maintenance on the Liebert STS2/PDU.

All power and control wiring must be installed by a licensed, properly trained and qualified electrician. All power and control wiring must comply with the National Electrical Code and all applicable local codes.

The input power busbars are accessible through the front of the unit. Liebert's 250A units have PEM nut inserts designed to allow one-handed tightening. Busbars in the 400-800A units are supplied with holes to accommodate two-hole lugs.

Cables can be installed through the top or bottom of the unit through removable conduits plates. Units with output inline panelboards are bottom exit only for output cables.

Unless otherwise labeled, use the recommended tightening torque shown in **Table 28**.

See **Figures 12** through **21** for wiring entrance locations.

4.1 Input and Output Power Connections

The input power connections are made to the busbars provided inside the unit (see **Figures 26** through **31**). These busbars are accessible through the front of the unit.

Output power connections are handled two different ways, depending on the type of distribution used. Power connections on standard units with an output breaker are made to the busbars inside the unit. These busbars are accessible through the front on 250A units and on the side on 400-800A units. See **Figures 26** through **31** for details on the busbars. Power connections on units with panelboard distribution are made directly to the panelboard breakers. Busbars are provided in the output cabinet for ground and neutral connections.



WARNING

Risk of electric shock. Can cause injury or death.

Verify that all input power and control circuits are de-energized and locked out before making connections inside unit.

The two input power feeds (sources) to the Liebert STS2/PDU should be from two independent sources to avoid a common source failure.

To ensure proper operation of the Liebert STS2/PDU, the two input sources must be the same nominal voltage level and phase rotation.

For uninterrupted automatic transfer, the two input sources should be synchronized within 15 degrees.

NOTICE

The input sources to the Liebert STS2/PDU must be grounded-wye sources. Input sources other than solidly grounded-wye sources may cause damage to the switch.

The Liebert STS2/PDU is designed for operation with 3-wire, solidly grounded sources only.

See **Figures 3** through **6** for typical one-line diagrams. Refer to **Figures 26** through **31** for electrical field connections on all units.

Figure 3 Typical Liebert STS2/PDU, one-line diagram

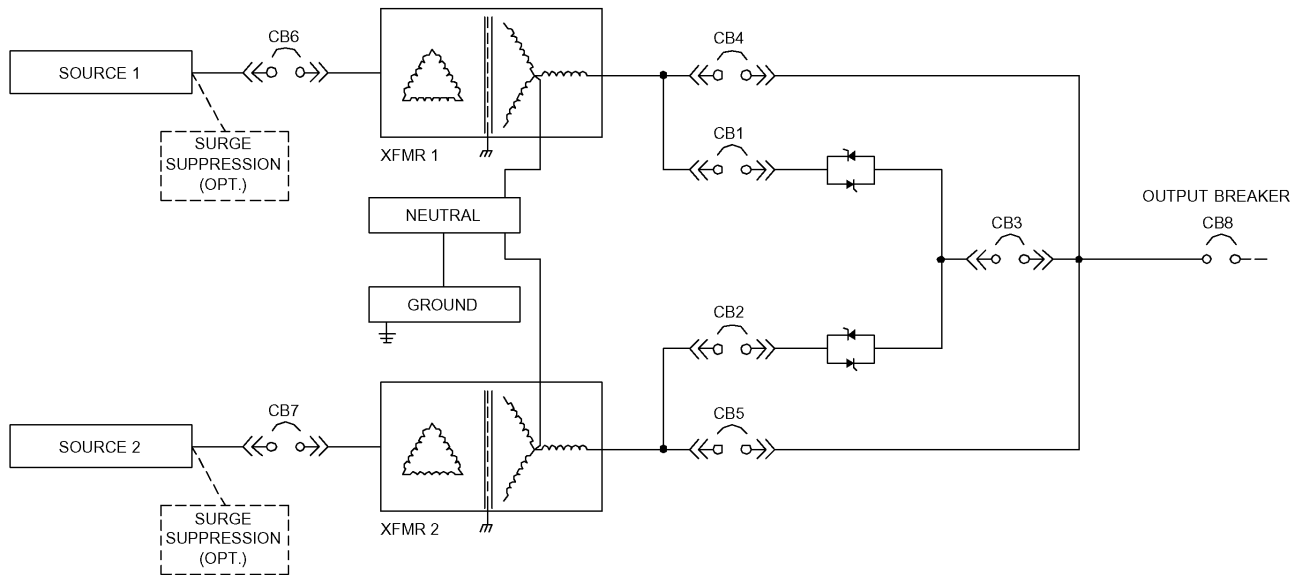

Figure 4 Typical Liebert STS2/PDU, one-line diagram, with dual static switch output circuit breakers (not available on 250A units)

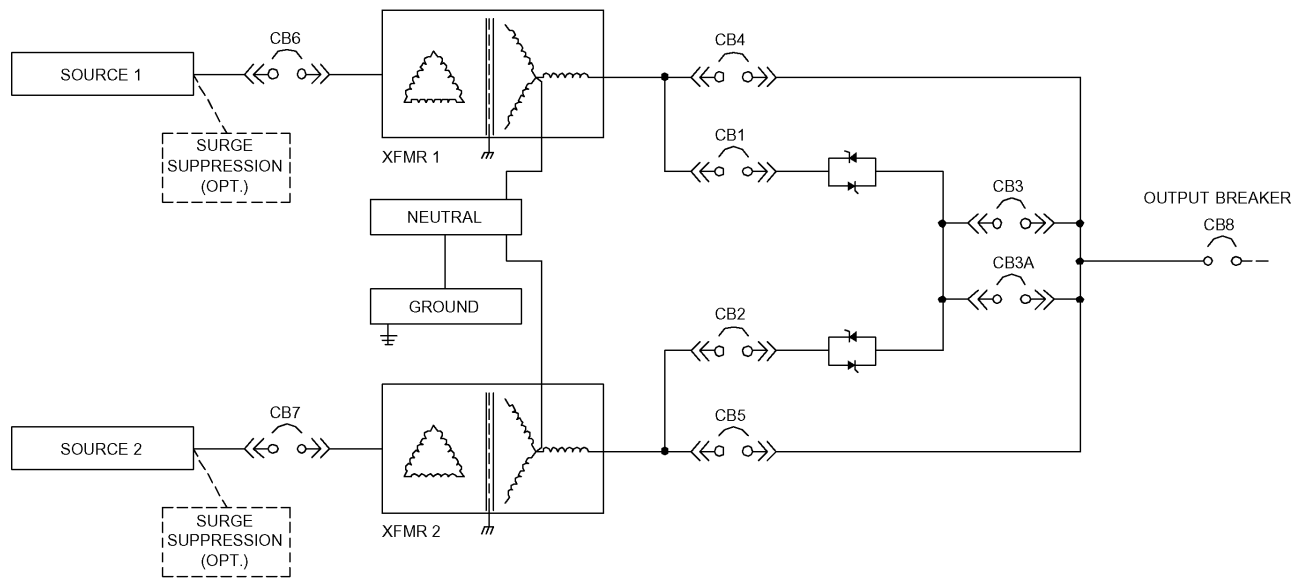

Figure 5 Typical Liebert STS2/PDU, one-line diagram, with inline distribution, dual static switch output circuit breakers

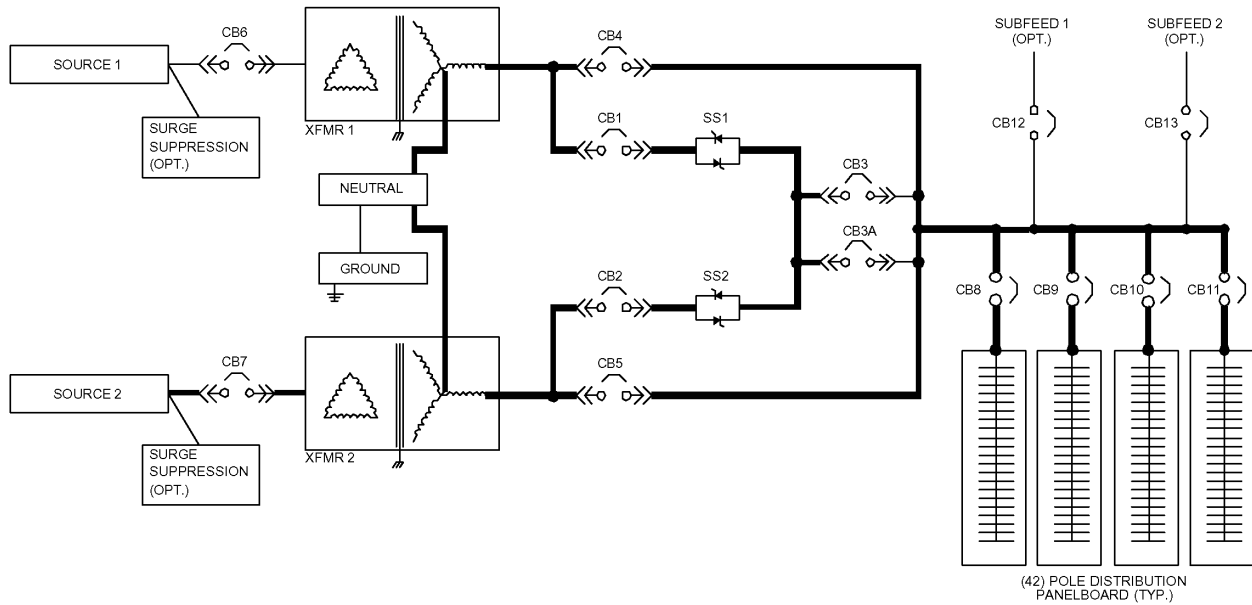
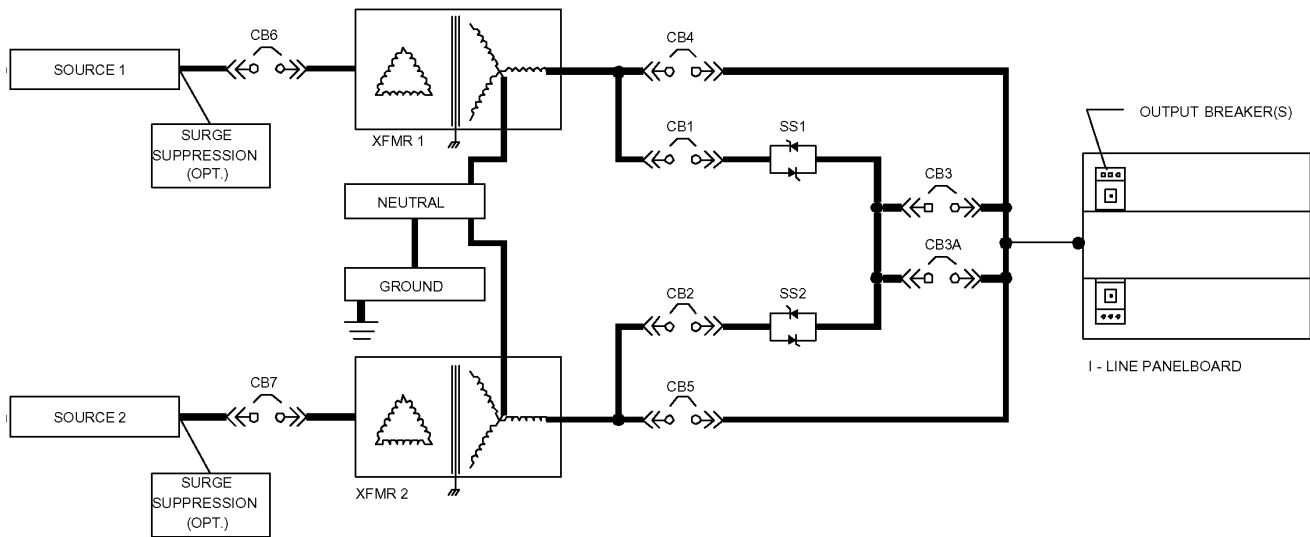

Figure 6 Typical Liebert STS2/PDU, one-line diagram, with I-Line distribution, dual static switch output circuit breakers



The input and output power wire size should be based on the overcurrent protection device, observing the NEC and local codes.

The Liebert STS2/PDU output power, ground and neutral busbars accommodate a wide range of wire sizes. The Liebert STS2/PDU busbars accommodate standard two-hole lugs.

Table 3 Input/output conduit plate specifications

Rating	Maximum Number of Conduits	Size, in.
250A	12	2"
	8	2-1/2"
	6	3" or 3-1/2"
400-600A	6	2"
	4	2-1/2" or 3"
800A	6	2-1/2"
	5	3" or 3-1/2"

4.2 System Grounding

Equipment grounding—Grounding is primarily for equipment and personnel safety, although proper grounding also enhances equipment performance.

All input and output power feeds must include an equipment grounding means as required by the NEC and local codes.

An insulated equipment ground conductor is recommended to run with each input and output power feed. The equipment ground conductors should be at least the minimum size conductor per the NEC based on the upstream overcurrent protection device.



WARNING

Risk of electric shock. Can cause injury or death.

If conduit is used as a grounding means, adequate electrical continuity must be maintained at all conduit connections. Using isolating bushings with a metal conduit can be a safety hazard.

4.3 Control Wiring Connections

No control wiring is needed on the standard Liebert STS2/PDU. Certain options and remote monitoring configurations require external control wiring. See **6.0 - Options** for details.

The customer must supply control wiring to the Liebert STS2/PDU for connection to any monitoring or communication options. Top and bottom removable conduit plates are provided for control wiring conduit.

Control cables can be installed through the top or bottom of the unit through removable control conduit plates. A top hat is provided on the 400-600A units for connecting the top entry control wiring conduits (see **Figures 13 through 21**). The top hat is turned upside down and ships inside the unit. It must be removed from the unit and flipped 180 degrees before being reinstalled (see **Figure 49**). The control wiring top hat does NOT contain any knockouts for conduit. The installer must drill the appropriate-sized holes for the conduit before attaching to the top of the Liebert STS2/PDU.

See **Figures 47 and 48** for arrangement of optional cards.

4.4 Remote Source Selection Wiring

An optional Remote Source Selection board may be installed in your Liebert STS2/PDU. This board is installed in the same bay as the communications options. See **Figures 47 and 48** for the location of these options. See **Figure 55** for information on the control wiring for the Remote Source Selection option.

The Remote Source Selection allows you choose the preferred input source from a remote location.

Terminal connections allow the customer to remotely select a source to be the preferred source in the same process as the local source transfer selection.

If both the input contacts are closed, the current selected preferred source shall be retained. If the unit's preferred source selection and Remote Source Selection are active at the same time, the Liebert STS2/PDU follows the last request for a preferred source change, regardless of whether it was from the local or Remote Source Selection controls.

A six pin terminal block provides the Remote Source Selection connections. Two pairs of wires are used from the switch to trigger the source selection. You can select the type of switch used for this remote control. Connections are made to four of the connections, using Form A dry contacts. The contacts are numbered left to right:

Table 4 Remote source selection terminal block

Contact	Connection
1	Source 1
2	Isolated ground
3	Source 2
4	Isolated Ground
5	DO NOT USE
6	DO NOT USE

See **10.3 - Enabling Remote Source Selection** for instructions on enabling the Remote Source Selection option.

4.5 Power Supply

The Liebert STS2/PDU is supplied with redundant power supplies that are designed to operate from a voltage range of 200V to 600V. The unit is set at the factory to match the nameplate voltage. Field adjustments are not necessary. If the unit needs to operate at a voltage other than what is listed on the nameplate, contact Liebert Services or your local Liebert representative. **Table 5** provides transformer tap information.

Table 5 Terminal block 1 and terminal block 2 wire connections

Voltage	Connect		Connect		Jumper Between
	F1 TB1-XX	F2 TB1-YY	F3 TB2-XX	F4 TB2-YY	
200	1	9	1	9	1-7
220	2	12	2	12	6-8
380	1	8	1	8	2-7
415	1	10	1	10	4-7
600	1	12	1	12	6-7
208	1	10	1	10	1-7
240	1	11	1	11	1-7
400	1	9	1	9	3-7
480	1	11	1	11	5-7

NOTICE

Using **Table 5**, ensure that the wiring for the control transformers matches the input voltage for the unit.

Improper wiring could result in blown fuses.

5.0 OUTPUT POWER WIRING

The Liebert STS2/PDU standard model is provided with a circuit breaker for connecting to the load or a remote distribution cabinet. Other distribution configurations are available.

The three main types of distributions available for the Liebert STS2/PDU are:

- **Output Breaker**
- **Inline Panelboards**—two panelboards (84 poles) on 250A units and four panelboards (168 poles) on 400-800A units. Square D[®] and General Electric panelboards are available to accommodate bolt-in or plug-in breakers.
- **Square D I-Line[®] Panelboard**—designed to accommodate up to 10 plug-in breakers from 100A to 250A. Additionally, 300A to 400A breakers are available on 800A units.

For other optional distribution methods, contact your local Liebert representative or call 1-800-LIEBERT.

The Liebert STS2/PDU distribution may be mounted on either the right or left side at the customer's option. Location of output conduit connections is affected by the location of the output cabinet. See **Figures 8, 9, 12, 13, 16 and 17** for wiring a right-side distribution configuration and **Figures 10, 11, 14, 15, 18 and 19** for wiring a left-side distribution configuration. See **Figures 23 through 44** for wiring.

See **Table 6** for wiring the various output options.

5.1 Customer Connections

The customer is responsible for connections from the Liebert STS2/PDU distribution to the connected load, either directly or through remote distribution cabinets.

Table 6 Distribution configurations

Distribution Type	For Details See Electrical Output Field Connections
Output Breaker	
250A	Figure 23
400-600A	Figure 33
800A	Figure 35
Inline Panelboards	
250A	Figure 30
400-800A	Figure 31
I-Line (Square D)	Figure 32

6.0 OPTIONS

This section discusses the options available for the Liebert STS2/PDU. The communications options are also discussed in **12.0 - Communication Interfaces**.



WARNING

Risk of electric shock. Can cause injury or death.

All options must be installed by Liebert Services or Liebert factory-authorized service provided by a Liebert distributor. The option area and customer control cable area contain hazardous voltages if any of the input sources are on, even when the unit is in bypass. Turn OFF all power sources before installing customer control cables to any option.

6.1 Programmable Relay Board

The programmable relay board (PRB) provides a means to trigger an external device when an event occurs in the Liebert STS2/PDU. Each PRB has 8 channels. Each channel has two sets of Form-C dry contacts, rated 1A @ 30VDC or 250mA @ 125VAC.

Any alarm or event may be programmed to any channel or channels. Up to ten (10) events may be programmed to a relay. If multiple events are grouped to one relay, group the events logically to simplify troubleshooting when an event is triggered. The same alarm or event may be programmed to more than one channel. Up to two programmable relay boards can be installed in the Liebert STS2/PDU for a total of 16 channels. Programming is performed through the touch screen display.

See **Configuring the Programmable Relay Board Settings on page 108** for default settings and instructions for reconfiguring the relays. See **Figures 47 and 48** for the location of the PRB. See **Figure 50** for wiring details. **Table 7** provides the PRB pinout.

Table 7 Programmable relay board pinout

	Channel	Pin No.	C	N.C.	N.O.	
TB1	CH1	A	1-3	1	2	3
		B	4-6	4	5	6
	CH2	A	7-9	7	8	9
		B	10-12	10	11	12
TB2	CH3	A	13-15	13	14	15
		B	1-3	1	2	3
	CH4	A	4-6	4	5	6
		B	7-9	7	8	9
	CH5	A	10-12	10	11	12
		B	13-15	13	14	15
TB3	CH6	A	1-3	1	2	3
		B	4-6	4	5	6
	CH7	A	7-9	7	8	9
		B	10-12	10	11	12
TB4	CH8	A	13-15	13	14	15
		B	1-3	1	2	3

Key: N.O. = Normally Open; N/C. = Normally Closed; C = Common

Note: Pin 16 not used on TB1, TB2 and TB3.

6.2 Input Contact Isolator Board

The Input Contact Isolator Board (ICI) provides a Liebert STS2/PDU module interface for up to eight external user alarm or message inputs to be routed through the Liebert STS2/PDU's alarm network. The eight contacts are normally open dry contacts. When a contact closes, an event is triggered.

The Input Contact Isolator options are configured through the Input Contact Isolator dialog box, which is accessed from the Comm Option dialog box on the touch screen display. You also can program the alarm messages through this dialog box. See **Configuring the Input Contact Isolator Settings on page 106** for instructions on configuring the connections.

See **Figures 47 and 48** for the location of the ICI. See **Figure 51** for wiring details.

6.3 Comms Board

The Comms Board provides a communication interface to Liebert SiteScan[®], site monitoring product and/or an external modem. Liebert SiteLink[®]-12 or Liebert SiteLink[®]-4 is required for Liebert SiteScan to communicate with the Liebert STS2/PDU.

The Comms Board is equipped with an RS-422 communication port for communication to a Liebert SiteScan monitoring system using a 2-wire twisted pair for reliable communication up to 1000 meters (3281 feet). Information available from the RS-422 port includes the present switch status information, all monitoring parameters and all active alarms.

The Comms Board is equipped with a modem interface for remote reporting of the present switch status information, alarm history information and the history of status screens that are triggered upon a major alarm event. The monitoring system software also supports an auto-dial feature that allows the system to automatically dial programmed phone numbers by way of a modem to report designated alarm conditions.

Programming the Comms Board is performed through the touch screen display. See **Comm Options on page 104** for details.

See **Figures 47** and **48** for the location of the Comms Board. See **Figure 52** for information on the control wiring.

6.4 Liebert IntelliSlot[®] Web/485 Card With Adapter

A Liebert IntelliSlot Web/485 Card With Adapter (IS-WEB485ADPT) enables the Liebert STS2/PDU to communicate to a network management system (NMS). The card provides the internal hardware and software to communicate, via SNMP, to any I.P.-based Ethernet network through an RJ-45 connector using Category 5 cabling.

The Liebert IS-WEB485ADPT provides redundant paths for communications that make it possible to connect to a Building Management System (BMS) using Modbus, while simultaneously communicating to a NMS through SNMP. A terminal block provides the connection to Modbus.

See **Figures 47** and **48** for the location of the Liebert IntelliSlot Web/485 Card With Adapter. See **Figure 53** for control wiring information.

If you have questions about the Liebert IS-WEB485ADPT, refer to the user guide SL-52615, available at Liebert's Web site, www.liebert.com

6.5 Remote Source Selection

The Remote Source Selection allows the preferred input source to be chosen from a remote location. A user supplied normally open dry contact allows the user to remotely select a source to be the preferred source in the same process as the local source transfer selection.

If both the input contacts are closed, the current selected preferred source shall be retained. If the unit's preferred source selection and Remote Source Selection are active at the same time, the Liebert STS2/PDU follows the last request for a preferred source change, regardless of whether it was from the local or Remote Source Selection controls.

See **10.3 - Enabling Remote Source Selection** for instructions on enabling the Remote Source Selection.

See **Figures 47** and **48** for the location of the Remote Source Selection option.

See **4.4 - Remote Source Selection Wiring** and **Figure 55** for information on the control wiring.

6.6 Key Lockout Switch

The key lockout switch activates a software lockout of the touch screen display to prevent manual transfers and configuration changes. When locked out, the touch screen becomes a read-only display. A key is needed to do manual transfers or change settings.

The alarm silence button is not disabled when in the lockout position.

The switch is located on the front of the unit next to the display; it is behind the front door but can be operated without opening the front door. See **Figures 20** through **22** for the key lockout switch location on each unit.

See **13.2.1 - Security** and **Figure 64** for instructions on using the key lockout switch.

6.7 Static Switch Redundant Output Breaker

A plug-in, non-automatic circuit breaker is provided which allows redundancy in the static switch output power path. The breaker is connected in parallel with the static switch output plug-in non-automatic circuit breaker.

6.8 Inline Panelboards

An output distribution cabinet with either Square D or General Electric inline panelboards with copper bus to accept bolt-in or plug-in circuit breakers. Each panelboard is individually protected by a 225A, 240V, 3-pole panelboard main circuit breaker.

Each panelboard includes a separate isolated neutral bus bar and a safety-ground bus bar for the neutral and safety-ground connections for at least 42 output circuits.

6.9 I-Line Panelboards

An output distribution cabinet with one vertically mounted Square D I-Line panelboard with copper bus to accept Square D three phase plug-in circuit breakers. The panelboard shall be totally enclosed with an accent cover.

6.10 Subfeed Breakers

Breakers for feeding remote panelboard(s) or other loads. Available in ratings of 225A or 400A.



NOTE

Only available on units with inline panelboards. 400A breaker not available on 250A units.

6.11 K-Factor Transformers

K20-rated double-shielded copper isolation transformer specially designed to accommodate highly nonlinear loads in accordance with UL 1561 (in place of standard isolation transformer).

6.12 Surge Suppression System

A fused and monitored high-energy, 80 kAmp/phase surge suppression system by Control Concepts connected to each input of the unit for superior surge suppression.

7.0 INSTALLATION DRAWINGS

Figure 7 Outline drawing, 250A Liebert STS2/PDU

NOTES:

1. ALL DIMENSIONS ARE IN INCHES AND (MILLIMETERS).
2. 18" (457MM) MIN. CLEARANCE ABOVE UNIT REQUIRED FOR AIR EXHAUST.
3. INSTALLATION AND SERVICE ACCESS REQUIRED IN FRONT ONLY.
4. HEAT OUTPUT: APPROX. 12,590 BTU/HR (3.69 KW/HR).
5. APPROX. WEIGHT - 3,310 LBS. (1510 KG).
6. UNIT BOTTOM IS STRUCTURALLY ADEQUATE FOR FORKLIFT HANDLING.
7. KEEP CABINET WITHIN 15 DEG. OF VERTICAL WHILE HANDLING.
8. COLOR - IBM OFF WHITE.
9. OPEN DOOR TO REPLACE AIR FILTER; DISPOSABLE TYPE, SIZE 1X25X25.
10. THREADED MOUNTING HOLES (SEE DETAIL A) ARE PROVIDED FOR SEISMIC ANCHORING OR FLOOR STAND. MOUNTING BOLTS MUST BE THREADED INTO THE UNIT MOUNTING HOLES FROM UNDERNEATH THE UNIT BASE. IF FLOOR STAND IS USED, THE CASTERS MUST REST ON THE FLOOR STAND TO SUPPORT THE WEIGHT OF THE UNIT.
11. TOP AND BOTTOM CABLE ENTRY AVAILABLE THROUGH REMOVABLE ACCESS PLATES. REMOVE, PUNCH TO SUIT CONDUIT SIZE AND REPLACE.

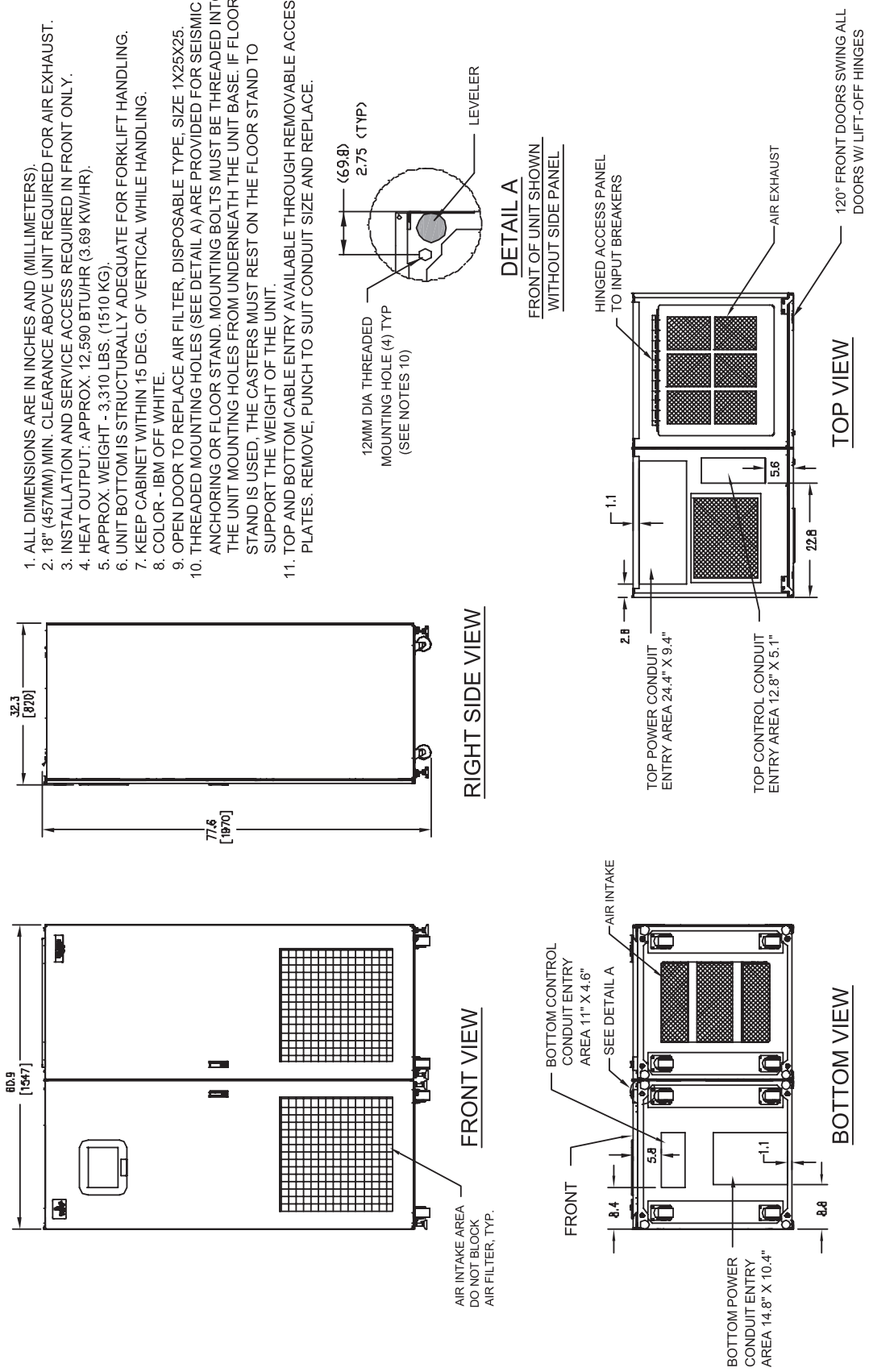

PSP11200
 Rev. 02

Figure 8 Outline drawing, 250A Liebert STS2/PDU with right side I-Line distribution

NOTES:

1. ALL DIMENSIONS ARE IN INCHES AND (MILLIMETERS).
2. APPROX. WEIGHT - 3530 LBS. (1601 KG).
3. 18" (457MM) CLEARANCE ABOVE UNIT REQUIRED FOR AIR EXHAUST.
4. INSTALLATION AND SERVICE ACCESS REQUIRED IN FRONT AND RIGHT SIDE ONLY.
5. KEEP CABINET WITHIN 15 DEG. OF VERTICAL WHILE HANDLING.
6. COLOR - IBM OFF WHITE.
7. UNIT BOTTOM IS STRUCTURALLY ADEQUATE FOR FORKTRUCK HANDLING.
8. HEAT OUTPUT: APPROX. 12,590 BTU/HR (3.69 KW/HR).
9. THREADED MOUNTING HOLES USED FOR SEISMIC ANCHORING OR FLOOR-STAND. NOTE: IF FLOORSTAND IS USED THE WEIGHT OF THE UNIT MUST BE SUPPORTED UNDER ALL CASTERS.
10. EACH MOUNTING LOCATION IS SUPPORTED BY (2) 10 GA. (.135") GALVANIZED STEEL. THE THREADED 12MM INSERT IS APPROX. 3/4" DEEP. MOUNTING BOLTS MUST BE THREADED INTO UNIT MOUNTING HOLES FROM UNDERNEATH UNIT BASE.
11. OPEN DOORS TO REPLACE AIR FILTER, DISPOSABLE TYPE SIZE 1 X 25 X 25.
12. TOP AND BOTTOM CABLE ENTRY AVAILABLE THROUGH REMOVABLE ACCESS PLATES. REMOVE, PUNCH TO SUIT CONDUIT SIZE AND REPLACE.

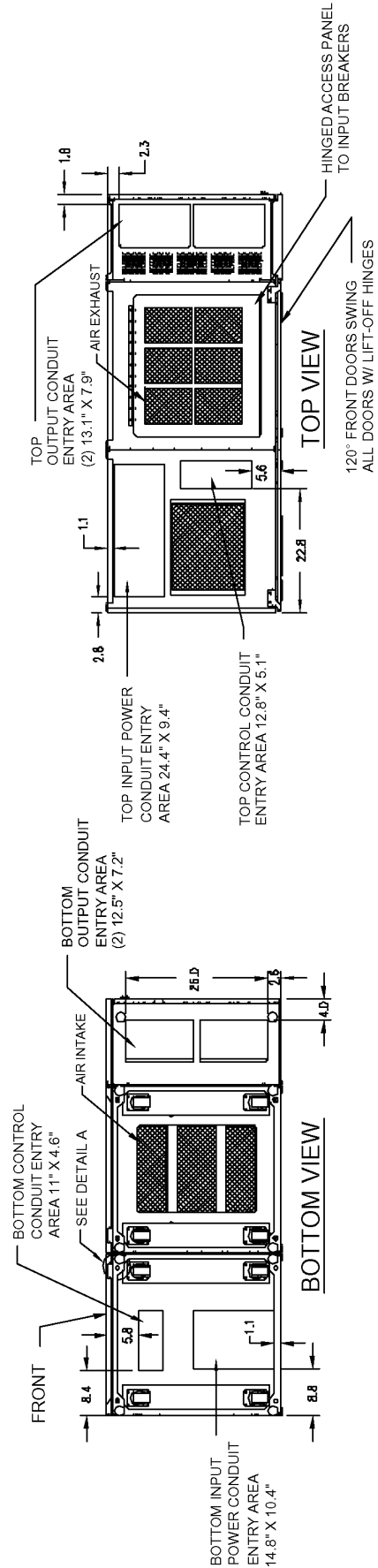
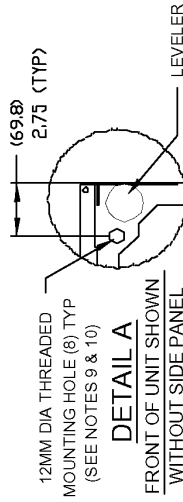
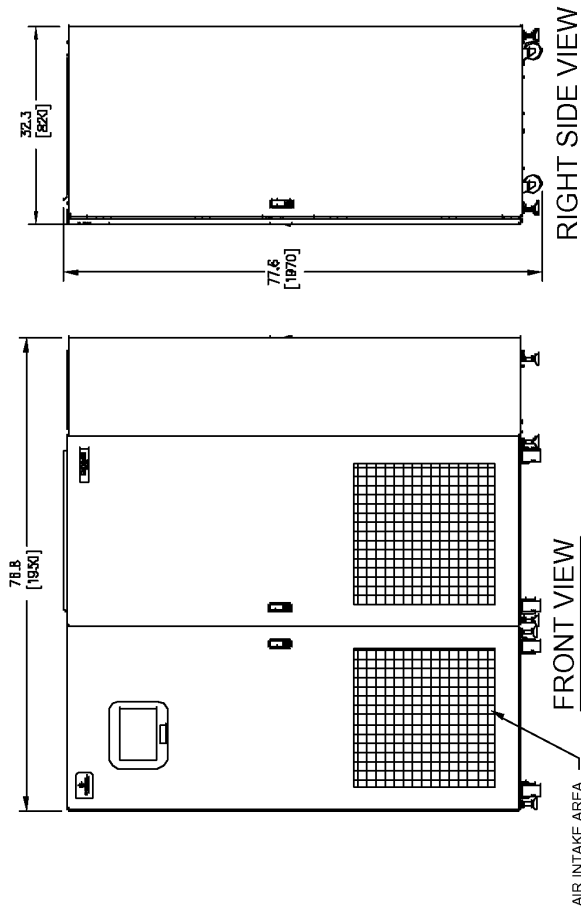

PSP1206
Rev. 0

Figure 10 Outline drawing, 250A Liebert STS2/PDU with left side I-Line distribution

NOTES:

1. ALL DIMENSIONS ARE IN INCHES AND (MILLIMETERS).
2. APPROX. WEIGHT - 3530 LBS. (1601 KG).
3. 18" (457MM) CLEARANCE ABOVE UNIT REQUIRED FOR AIR EXHAUST.
4. INSTALLATION AND SERVICE ACCESS REQUIRED IN FRONT AND LEFT SIDE ONLY.
5. KEEP CABINET WITHIN 15 DEG. OF VERTICAL WHILE HANDLING.
6. COLOR - IBM OFF WHITE.
7. UNIT BOTTOM IS STRUCTURALLY ADEQUATE FOR FORKTRUCK HANDLING.
8. HEAT OUTPUT: APPROX. 12,590 BTU/HR (3.69 KW/HR).
9. THREADED MOUNTING HOLES USED FOR SEISMIC ANCHORING OR FLOOR STAND. NOTE, IF FLOOR STAND IS USED THE WEIGHT OF THE UNIT MUST BE SUPPORTED UNDER ALL CASTERS.
10. EACH MOUNTING LOCATION IS SUPPORTED BY (2) 10 GA. (.135") GALVANIZED STEEL. THE THREADED 12MM INSERT IS APPROX. 3/4" DEEP. MOUNTING BOLTS MUST BE THREADED INTO UNIT MOUNTING HOLES FROM UNDERNEATH UNIT BASE.
11. OPEN DOORS TO REPLACE AIR FILTER, DISPOSABLE TYPE SIZE 1 X 25 X 25.
12. TOP AND BOTTOM CABLE ENTRY AVAILABLE THROUGH REMOVABLE ACCESS PLATES. REMOVE, PUNCH TO SUIT CONDUIT SIZE AND REPLACE.

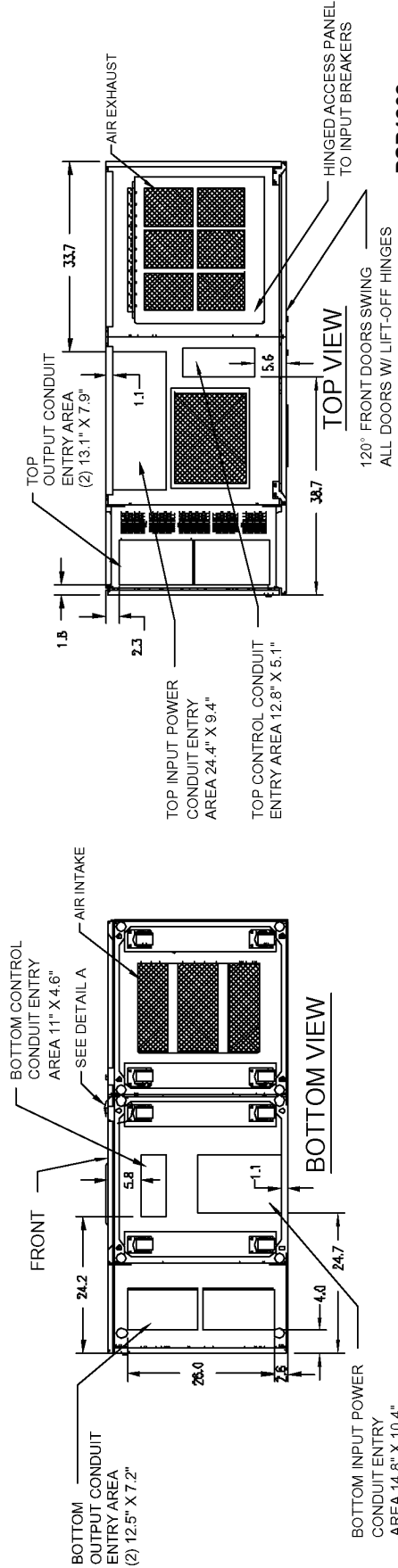
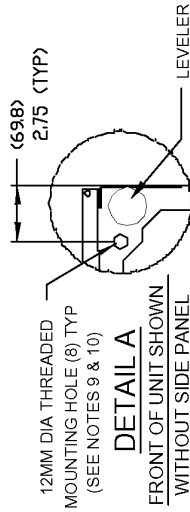
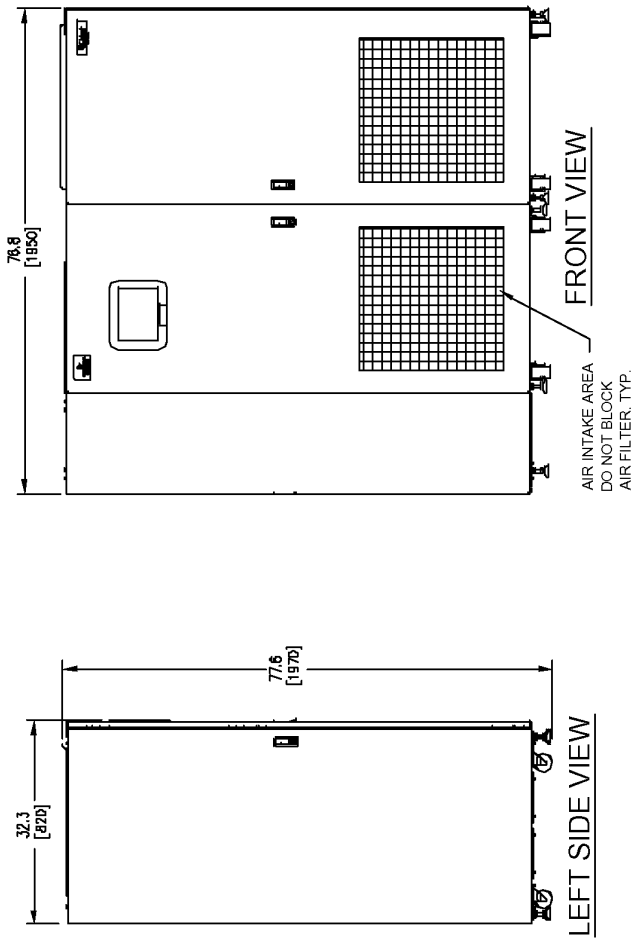

PSP1202
 Rev. 0

Figure 11 Outline drawing, 250A Liebert STS2/PDU with left side Inline distribution

NOTES:

1. ALL DIMENSIONS ARE IN INCHES AND (MILLIMETERS).
2. APPROX. WEIGHT - 3530 LBS. (1601 KG).
3. 18" (457MM) CLEARANCE ABOVE UNIT REQUIRED FOR AIR EXHAUST.
4. INSTALLATION AND SERVICE ACCESS REQUIRED IN FRONT AND LEFT SIDE ONLY.
5. KEEP CABINET WITHIN 15 DEG. OF VERTICAL WHILE HANDLING.
6. COLOR - IBM OFF WHITE.
7. UNIT BOTTOM IS STRUCTURALLY ADEQUATE FOR FORKTRUCK HANDLING.
8. HEAT OUTPUT: APPROX. 12,590 BTU/HR (3.69 KW/HR).
9. THREADED MOUNTING HOLES USED FOR SEISMIC ANCHORING OR FLOOR-STAND. NOTE, IF FLOORSTAND IS USED THE WEIGHT OF THE UNIT MUST BE SUPPORTED UNDER ALL CASTERS.
10. EACH MOUNTING LOCATION IS SUPPORTED BY (2) 10 GA. (.135") GALVANIZED STEEL. THE THREADED 12MM INSERT IS APPROX. 3/4" DEEP. MOUNTING BOLTS MUST BE THREADED INTO UNIT MOUNTING HOLES FROM UNDERNEATH UNIT BASE.
11. OPEN DOORS TO REPLACE AIR FILTER. DISPOSABLE TYPE SIZE 1 X 25 X 25.
12. TOP AND BOTTOM CABLE ENTRY AVAILABLE THROUGH REMOVABLE ACCESS PLATES. REMOVE, PUNCH TO SUIT CONDUIT SIZE AND REPLACE.

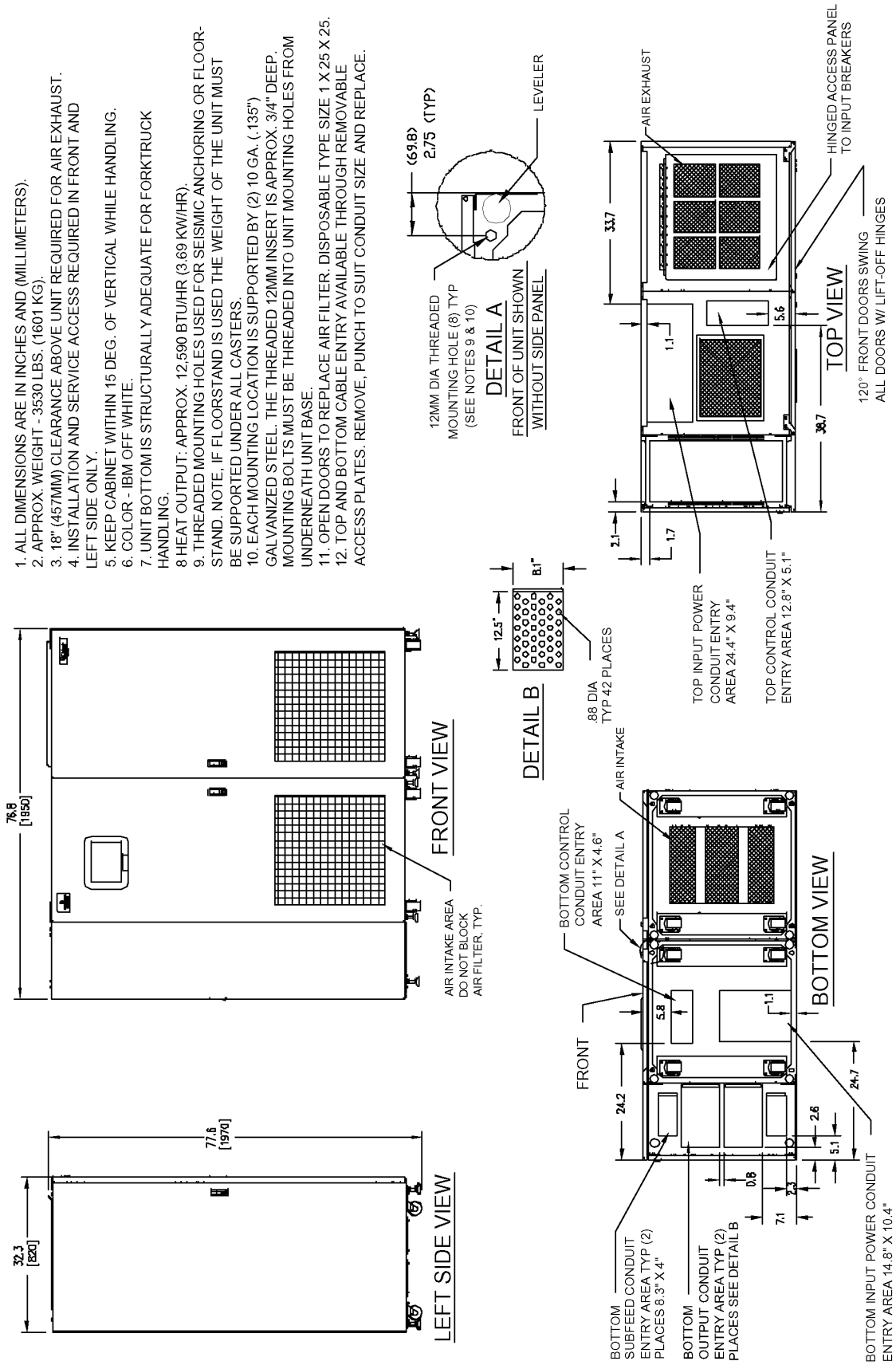

PSP11203
Rev. 0

Figure 12 Outline drawing, 400-600A Liebert STS2/PDU with right side inline distribution

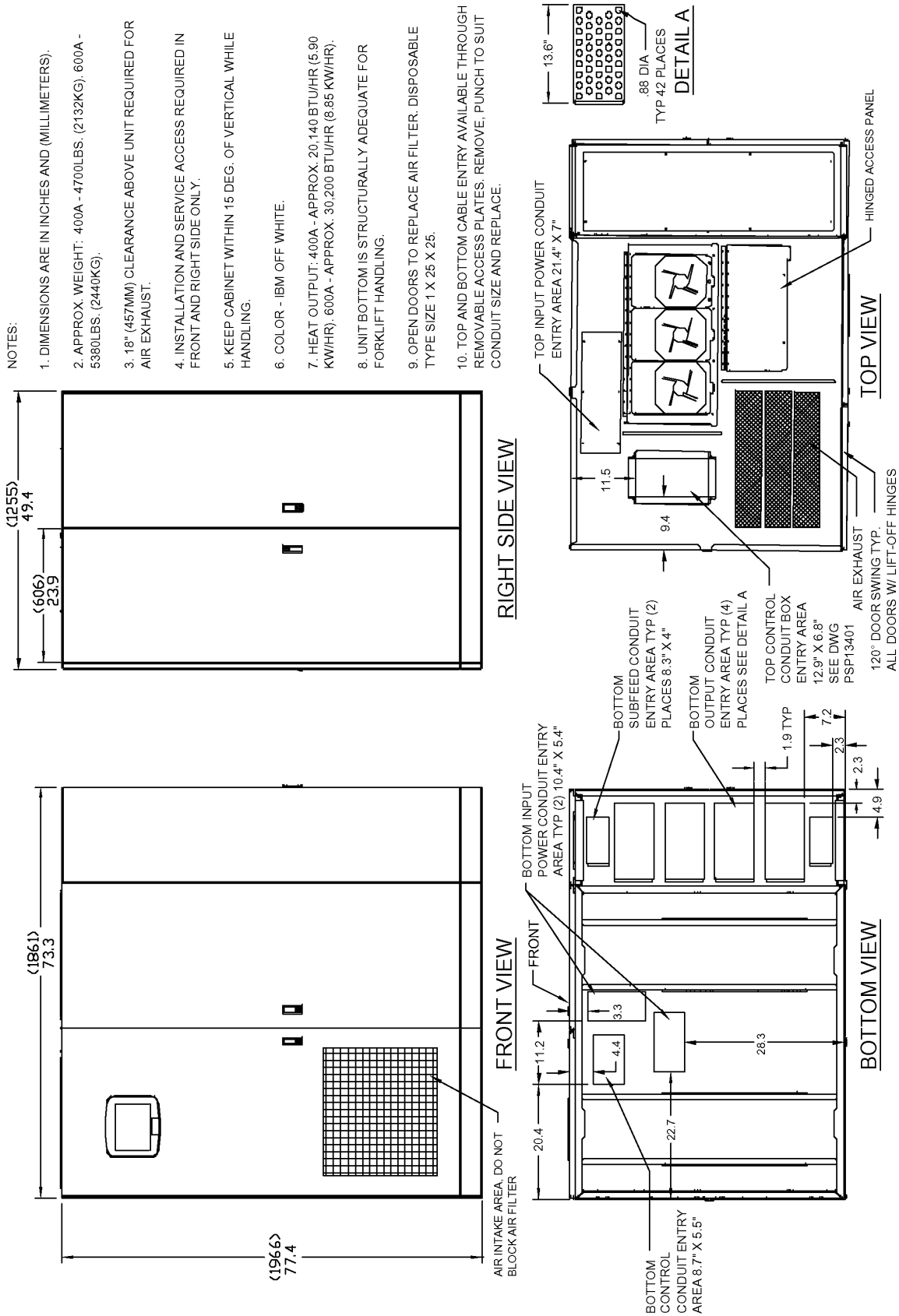

- NOTES:
1. DIMENSIONS ARE IN INCHES AND (MILLIMETERS).
 2. APPROX. WEIGHT: 400A - 4700LBS. (2132KG), 600A - 5380LBS. (2440KG).
 3. 18" (457MM) CLEARANCE ABOVE UNIT REQUIRED FOR AIR EXHAUST.
 4. INSTALLATION AND SERVICE ACCESS REQUIRED IN FRONT AND RIGHT SIDE ONLY.
 5. KEEP CABINET WITHIN 15 DEG. OF VERTICAL WHILE HANDLING.
 6. COLOR - IBM OFF WHITE.
 7. HEAT OUTPUT: 400A - APPROX. 20,140 BTU/HR (5.90 KW/HR); 600A - APPROX. 30,200 BTU/HR (8.85 KW/HR).
 8. UNIT BOTTOM IS STRUCTURALLY ADEQUATE FOR FORKLIFT HANDLING.
 9. OPEN DOORS TO REPLACE AIR FILTER, DISPOSABLE TYPE SIZE 1 X 25 X 25.
 10. TOP AND BOTTOM CABLE ENTRY AVAILABLE THROUGH REMOVABLE ACCESS PLATES. REMOVE, PUNCH TO SUIT CONDUIT SIZE AND REPLACE.

PSP11400
 Rev. 02

Figure 13 Outline drawing, 400-600A Liebert STS2/PDU with right side output breaker or I-Line distribution

- NOTES:
1. DIMENSIONS ARE IN INCHES AND (MILLIMETERS).
 2. APPROX. WEIGHT: 400A - 4700LBS. (2132KG); 600A - 5360LBS. (2440KG).
 3. 18" (457MM) CLEARANCE ABOVE UNIT REQUIRED FOR AIR EXHAUST.
 4. INSTALLATION AND SERVICE ACCESS REQUIRED IN FRONT AND RIGHT SIDE ONLY.
 5. KEEP CABINET WITHIN 15 DEG. OF VERTICAL WHILE HANDLING.
 6. COLOR - IBM OFF WHITE.
 7. HEAT OUTPUT: 400A - APPROX. 20,140 BTU/HR (5.90 KW/HR); 600A - APPROX. 30,200 BTU/HR (8.85 KW/HR).
 8. UNIT BOTTOM IS STRUCTURALLY ADEQUATE FOR FORKLIFT HANDLING.
 9. OPEN DOORS TO REPLACE AIR FILTER. DISPOSABLE TYPE SIZE 1 X 25 X 25.
 10. TOP AND BOTTOM CABLE ENTRY AVAILABLE THROUGH REMOVABLE ACCESS PLATES. REMOVE, PUNCH TO SUIT CONDUIT SIZE AND REPLACE.

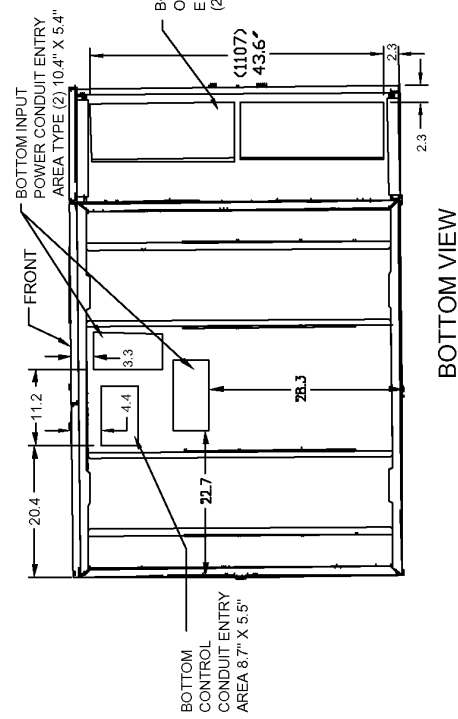
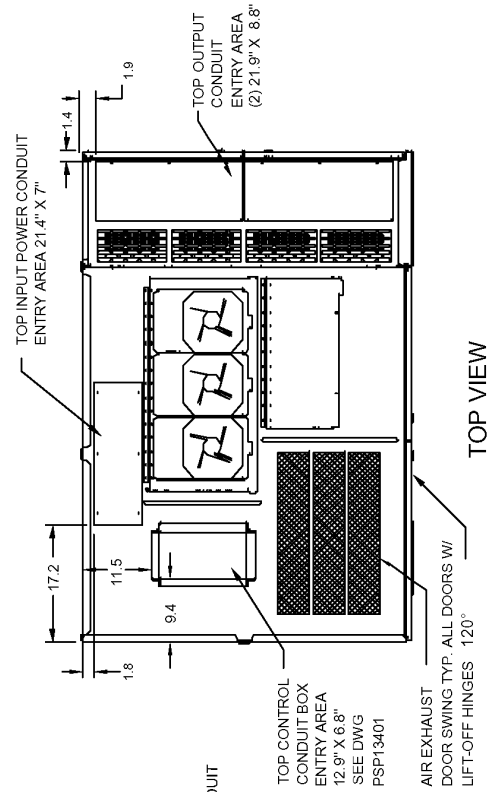
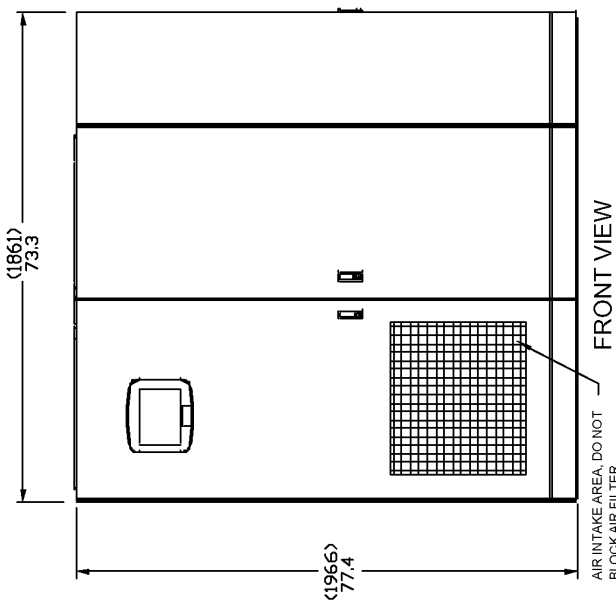

PSP11401
Rev. 02

Figure 14 Outline drawing, 400-600A Liebert STS2/PDU with left side inline distribution

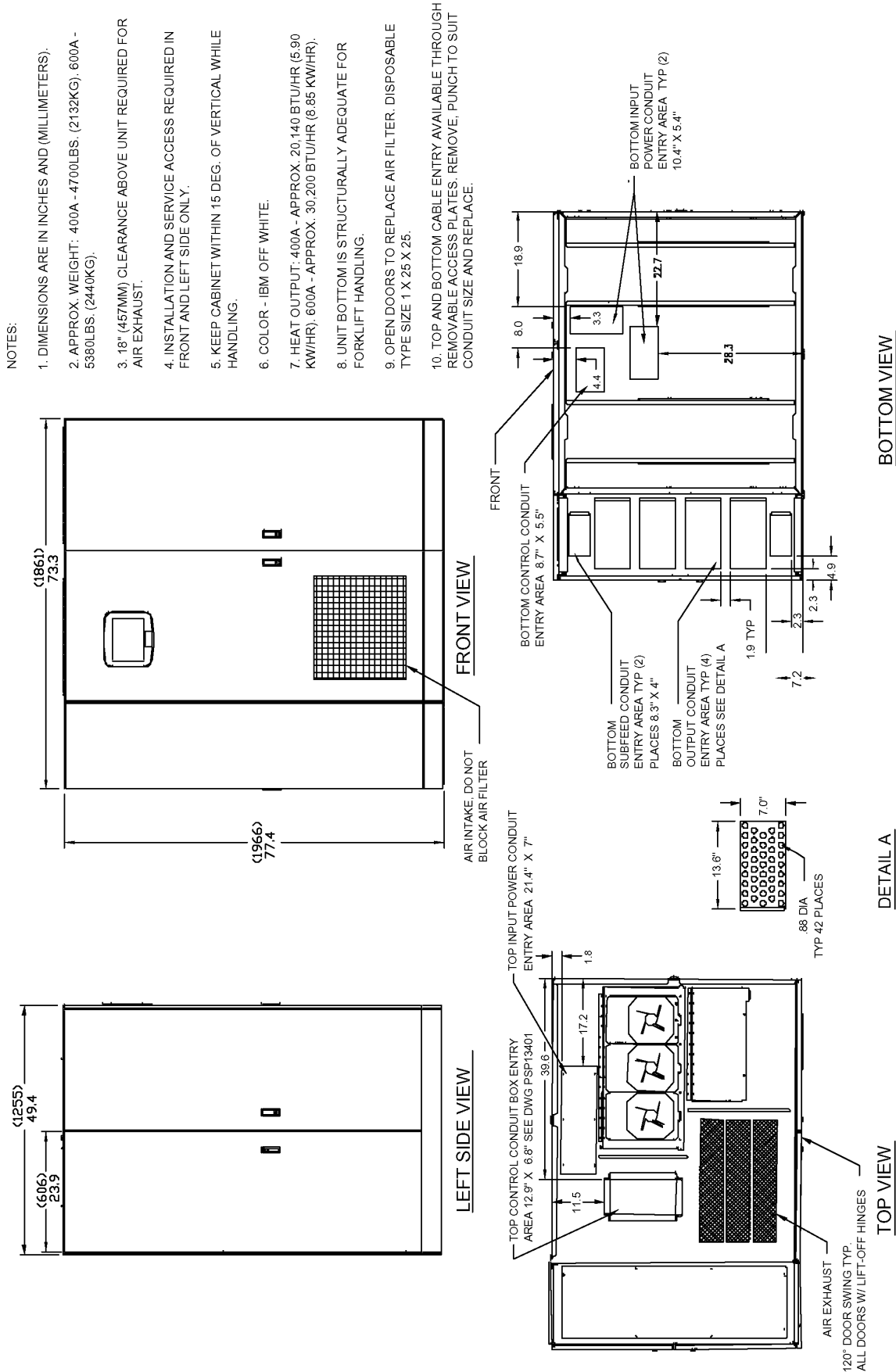

NOTES:

1. DIMENSIONS ARE IN INCHES AND (MILLIMETERS).
2. APPROX. WEIGHT: 400A - 4700LBS. (2132KG); 600A - 5380LBS. (2440KG).
3. 18" (457MM) CLEARANCE ABOVE UNIT REQUIRED FOR AIR EXHAUST.
4. INSTALLATION AND SERVICE ACCESS REQUIRED IN FRONT AND LEFT SIDE ONLY.
5. KEEP CABINET WITHIN 15 DEG. OF VERTICAL WHILE HANDLING.
6. COLOR - IBM OFF WHITE.
7. HEAT OUTPUT: 400A - APPROX. 20,140 BTU/HR (5.90 KW/HR); 600A - APPROX. 30,200 BTU/HR (8.85 KW/HR).
8. UNIT BOTTOM IS STRUCTURALLY ADEQUATE FOR FORKLIFT HANDLING.
9. OPEN DOORS TO REPLACE AIR FILTER. DISPOSABLE TYPE SIZE 1 X 25 X 25.
10. TOP AND BOTTOM CABLE ENTRY AVAILABLE THROUGH REMOVABLE ACCESS PLATES. REMOVE, PUNCH TO SUIT CONDUIT SIZE AND REPLACE.

PSP11402
 Rev. 01

Figure 15 Outline drawing, 400-600A Liebert STS2/PDU with left side output breaker or I-Line distribution

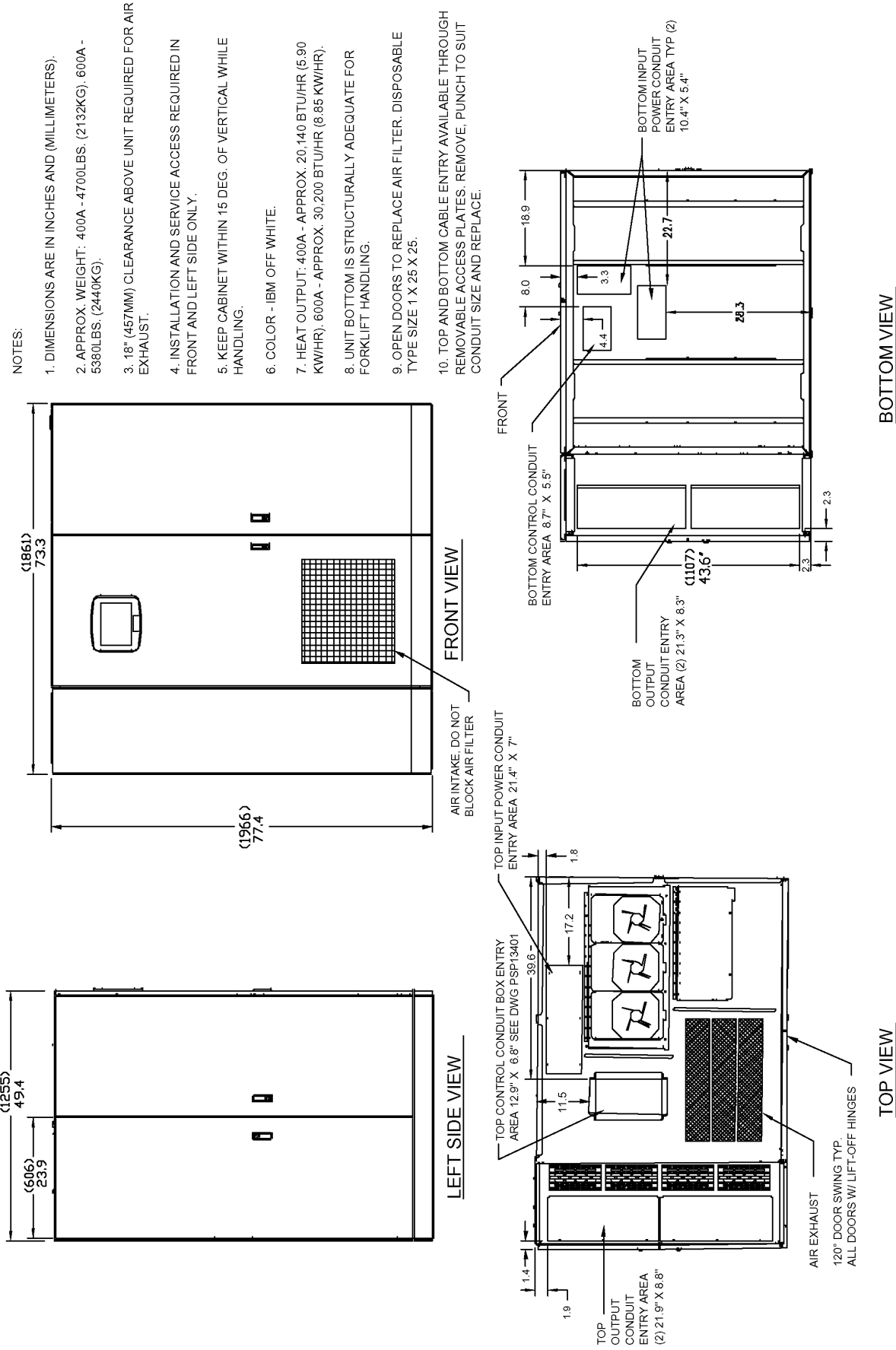

PSP11403
Rev. 01

Figure 16 Outline drawing, 800A Liebert STS2/PDU with right side output breaker or I-Line distribution

- NOTES:
1. DIMENSIONS ARE IN INCHES AND (MILLIMETERS).
 2. APPROX. WEIGHT: 8362LBS. (37893KG).
 3. 18" (457MM) CLEARANCE ABOVE UNIT REQUIRED FOR AIR EXHAUST.
 4. INSTALLATION AND SERVICE ACCESS REQUIRED IN FRONT AND RIGHT SIDE ONLY.
 5. KEEP CABINET WITHIN 15 DEG. OF VERTICAL WHILE HANDLING.
 6. COLOR - IBM OFF WHITE.
 7. HEAT OUTPUT: APPROX. 40,270 BTU/HR (11.8 KW/HR).
 8. UNIT BOTTOM IS STRUCTURALLY ADEQUATE FOR FORKLIFT HANDLING.
 9. OPEN DOORS TO REPLACE AIR FILTER, DISPOSABLE TYPE SIZE 1 X 25 X 25.
 10. TOP AND BOTTOM CABLE ENTRY AVAILABLE THROUGH REMOVABLE ACCESS PLATES. REMOVE, PUNCH TO SUIT CONDUIT SIZE AND REPLACE.

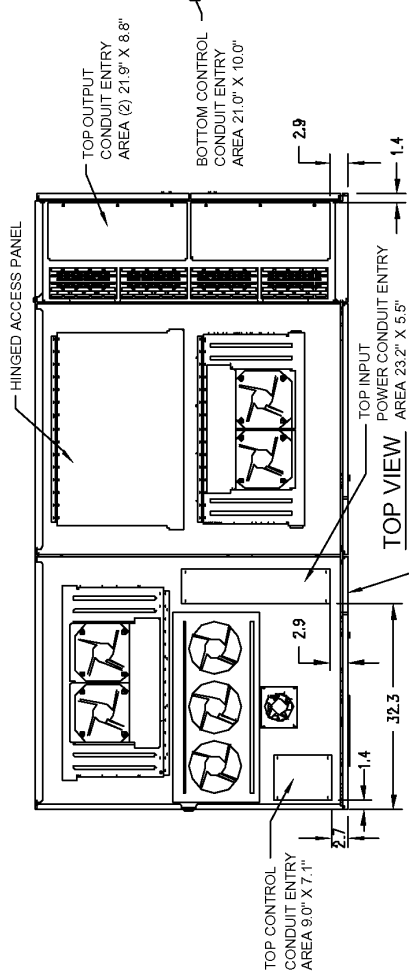
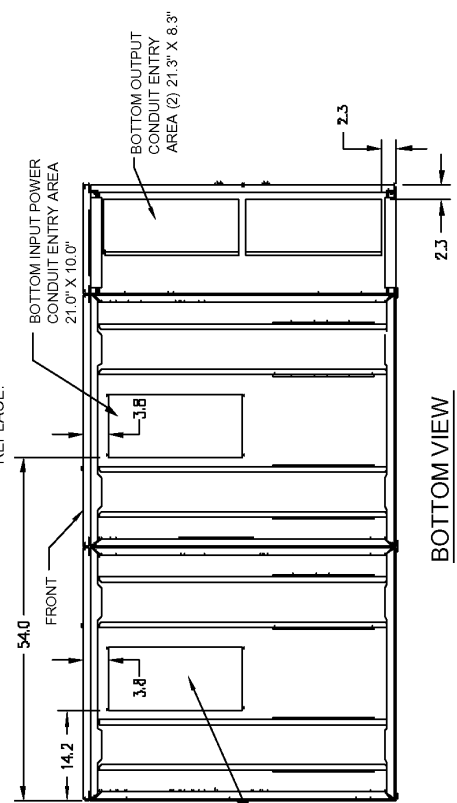
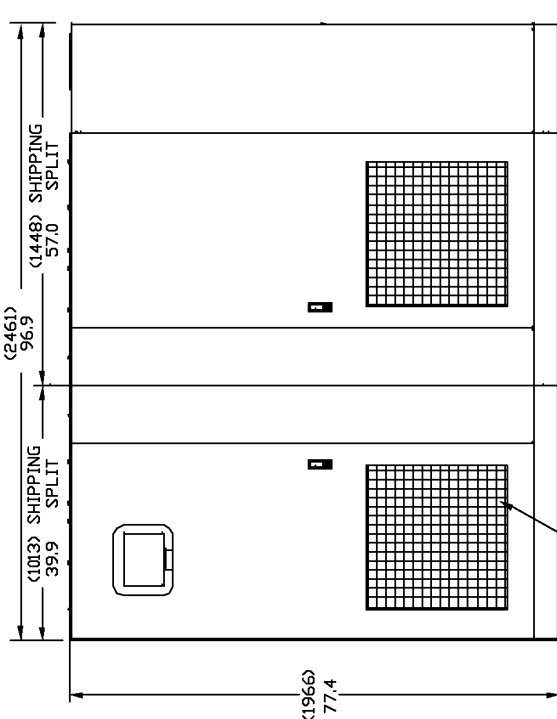
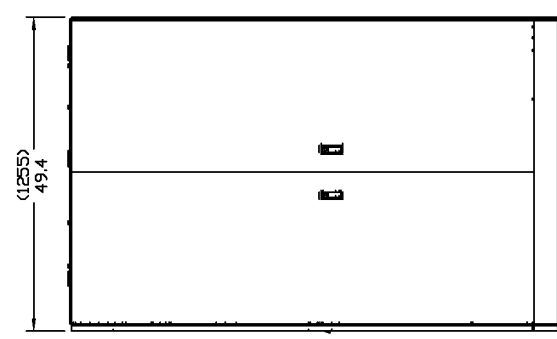

PSP11800
Rev. 01

Figure 17 Outline drawing, 800A Liebert STS2/PDU with right side inline distribution

- NOTES:
1. DIMENSIONS ARE IN INCHES AND (MILLIMETERS).
 2. APPROX. WEIGHT: 8362LBS. (3793KG).
 3. 18" (457MM) CLEARANCE ABOVE UNIT REQUIRED FOR AIR EXHAUST.
 4. INSTALLATION AND SERVICE ACCESS REQUIRED IN FRONT AND RIGHT SIDE ONLY.
 5. KEEP CABINET WITHIN 15 DEG. OF VERTICAL WHILE HANDLING.
 6. COLOR - IBM OFF WHITE.
 7. HEAT OUTPUT: APPROX. 40,270 BTU/HR (11.8 KW/HR).
 8. UNIT BOTTOM IS STRUCTURALLY ADEQUATE FOR FORKLIFT HANDLING.
 9. OPEN DOORS TO REPLACE AIR FILTER. DISPOSABLE TYPE SIZE 1 X 25 X 25.
 10. TOP AND BOTTOM CABLE ENTRY AVAILABLE THROUGH REMOVABLE ACCESS PLATES. REMOVE, PUNCH TO SUIT CONDUIT SIZE AND REPLACE.

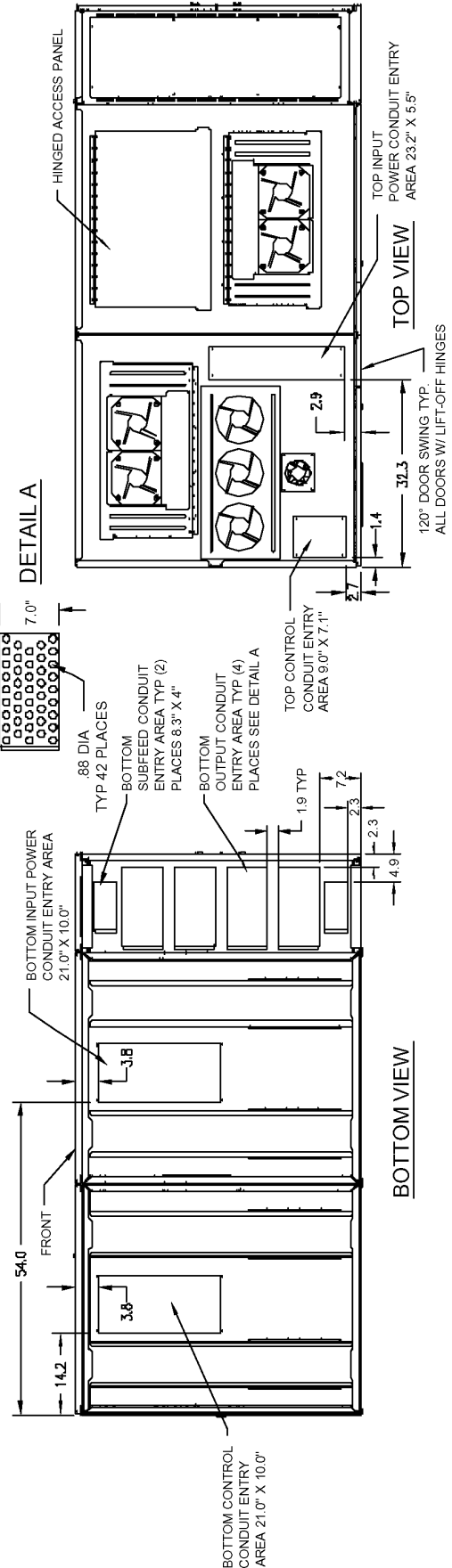
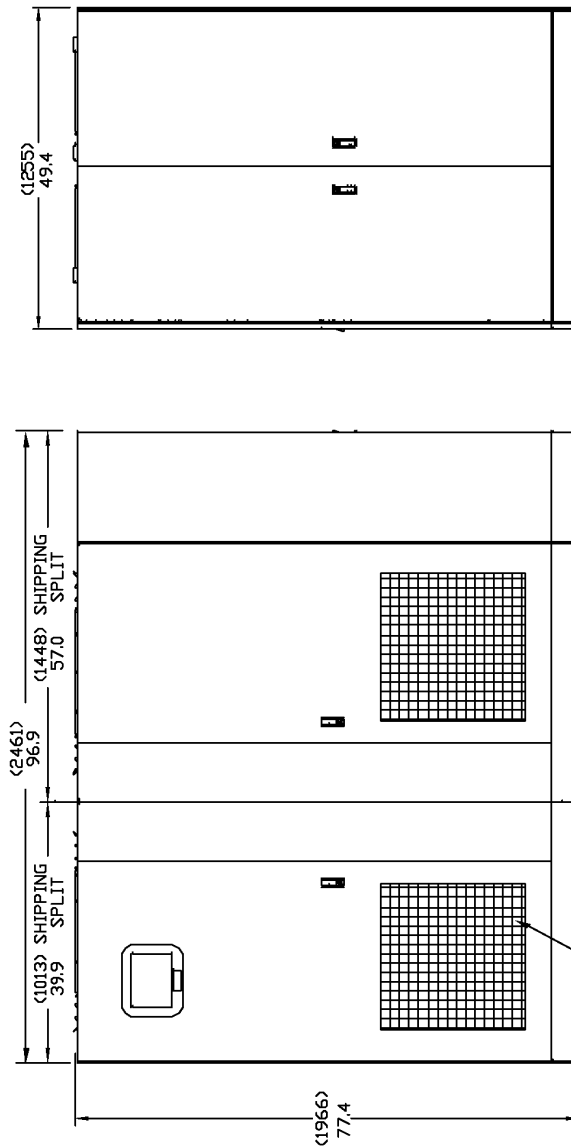

PSP11801
Rev. 0

Figure 18 Outline drawing, 800A Liebert STS2/PDU with left side output breaker or I-Line distribution

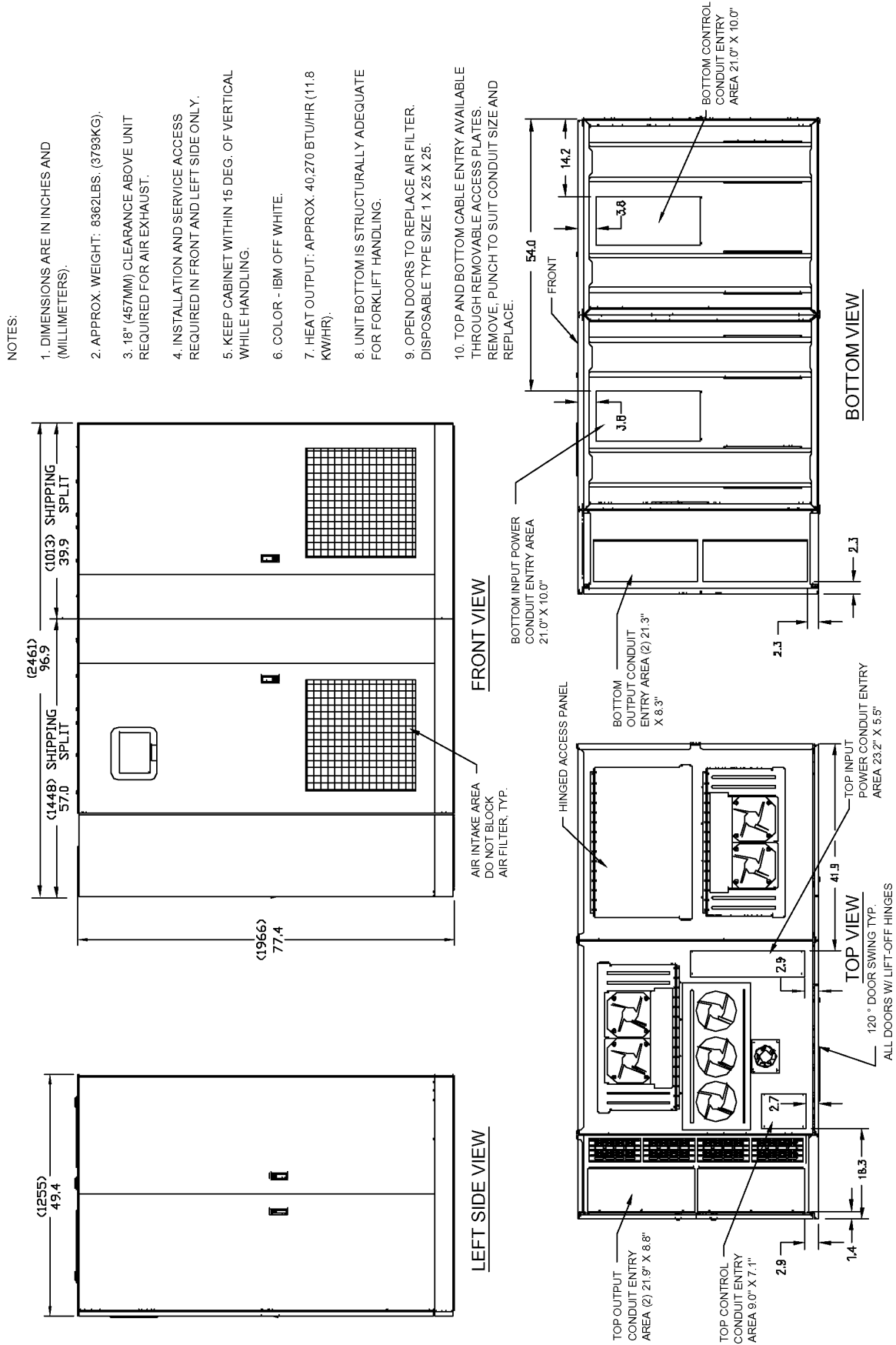

PSP11802
Rev. 0

Figure 19 Outline drawing, 800A Liebert STS2/PDU with left side inline distribution

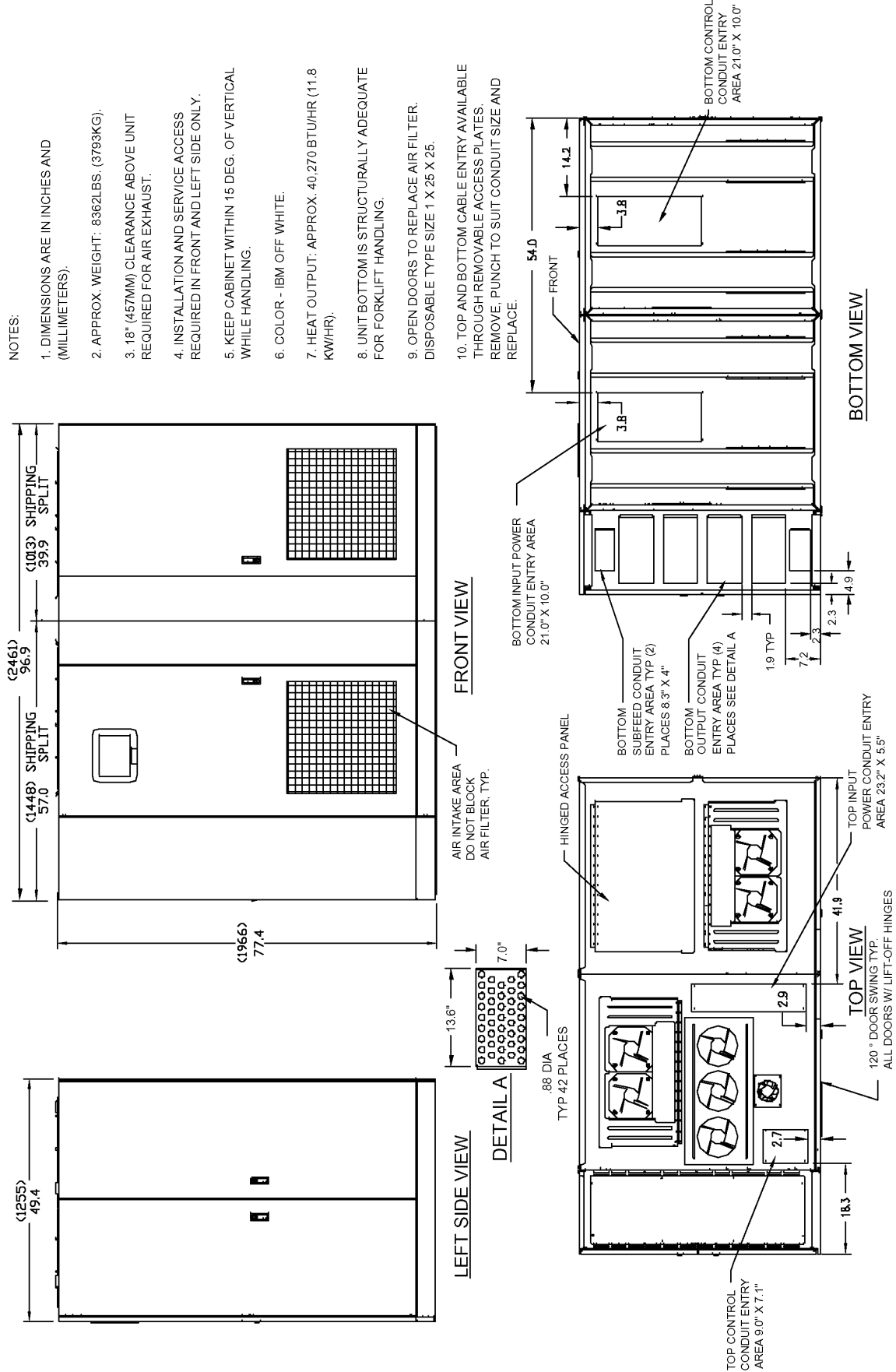

PSP11803
Rev. 0

Figure 20 Outline drawing, 250A Liebert STS2/PDU with key lockout switch option

NOTES:

1. ALL DIMENSIONS ARE IN INCHES AND (MILLIMETERS).
2. 18" (457MM) MIN. CLEARANCE ABOVE UNIT REQUIRED FOR AIR EXHAUST.
3. INSTALLATION AND SERVICE ACCESS REQUIRED IN FRONT ONLY.
4. HEAT OUTPUT: APPROX. 12,590 BTU/HR (3.69 KW/HR).
5. APPROX. WEIGHT - 3,310 LBS. (1510 KG).
6. UNIT BOTTOM IS STRUCTURALLY ADEQUATE FOR FORKLIFT HANDLING.
7. KEEP CABINET WITHIN 15 DEG. OF VERTICAL WHILE HANDLING.
8. COLOR - IBM OFF WHITE.
9. OPEN DOOR TO REPLACE AIR FILTER, DISPOSABLE TYPE, SIZE 1X25X25.
10. THREADED MOUNTING HOLES (SEE DETAIL A) ARE PROVIDED FOR SEISMIC ANCHORING OR FLOOR STAND. MOUNTING BOLTS MUST BE THREADED INTO THE UNIT MOUNTING HOLES FROM UNDERNEATH THE UNIT BASE. IF FLOOR STAND IS USED, THE CASTERS MUST REST ON THE FLOOR STAND TO SUPPORT THE WEIGHT OF THE UNIT.
11. TOP AND BOTTOM CABLE ENTRY AVAILABLE THROUGH REMOVABLE ACCESS PLATES. REMOVE, PUNCH TO SUIT CONDUIT SIZE AND REPLACE.

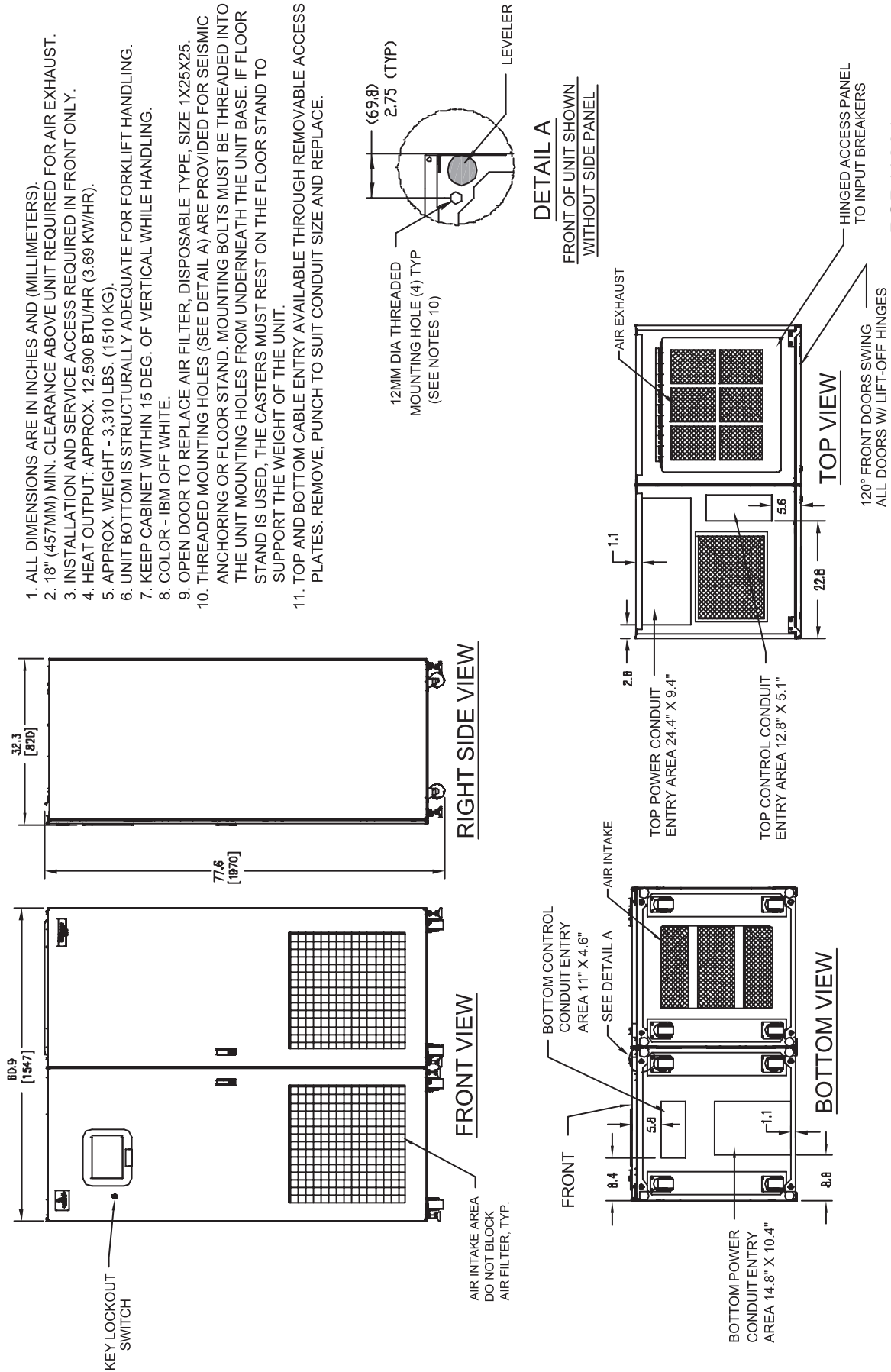

PSP11201
 Rev. 01

Figure 21 Outline drawing, 400-600A Liebert STS2/PDU, inline distribution, right side with key lockout switch option

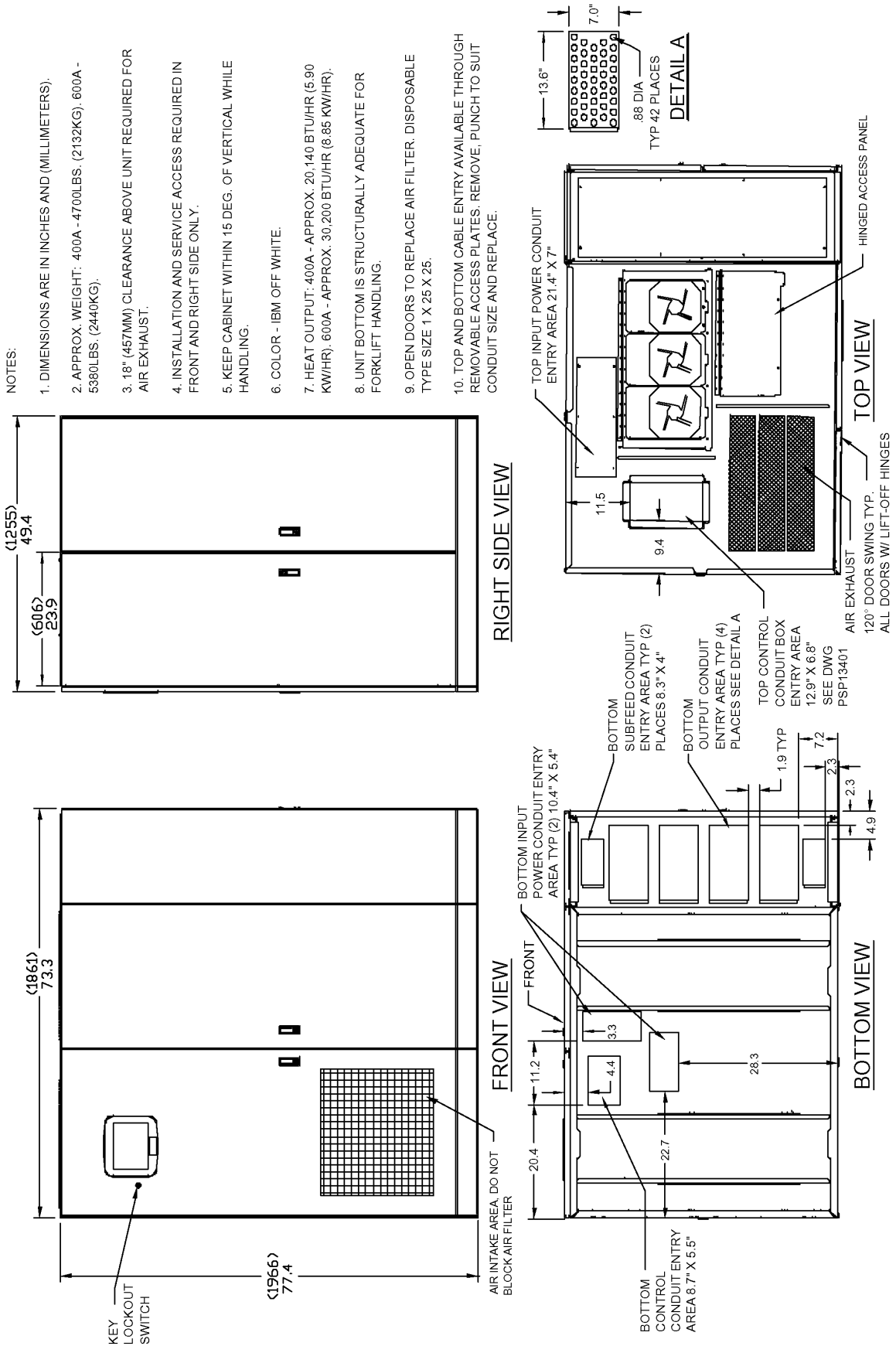

- NOTES:
1. DIMENSIONS ARE IN INCHES AND (MILLIMETERS).
 2. APPROX. WEIGHT: 400A - 4700LBS. (2132KG), 600A - 5380LBS. (2440KG).
 3. 18" (457MM) CLEARANCE ABOVE UNIT REQUIRED FOR AIR EXHAUST.
 4. INSTALLATION AND SERVICE ACCESS REQUIRED IN FRONT AND RIGHT SIDE ONLY.
 5. KEEP CABINET WITHIN 15 DEG. OF VERTICAL WHILE HANDLING.
 6. COLOR - IBM OFF WHITE.
 7. HEAT OUTPUT: 400A - APPROX. 20,140 BTU/HR (5.90 KW/HR), 600A - APPROX. 30,200 BTU/HR (8.85 KW/HR).
 8. UNIT BOTTOM IS STRUCTURALLY ADEQUATE FOR FORKLIFT HANDLING.
 9. OPEN DOORS TO REPLACE AIR FILTER. DISPOSABLE TYPE SIZE 1 X 25 X 25.
 10. TOP AND BOTTOM CABLE ENTRY AVAILABLE THROUGH REMOVABLE ACCESS PLATES. REMOVE, PUNCH TO SUIT CONDUIT SIZE AND REPLACE.

PSP11407
 Rev. 01

Figure 22 Outline drawing, 800A Liebert STS2/PDU, inline distribution, right side with key lockout switch option

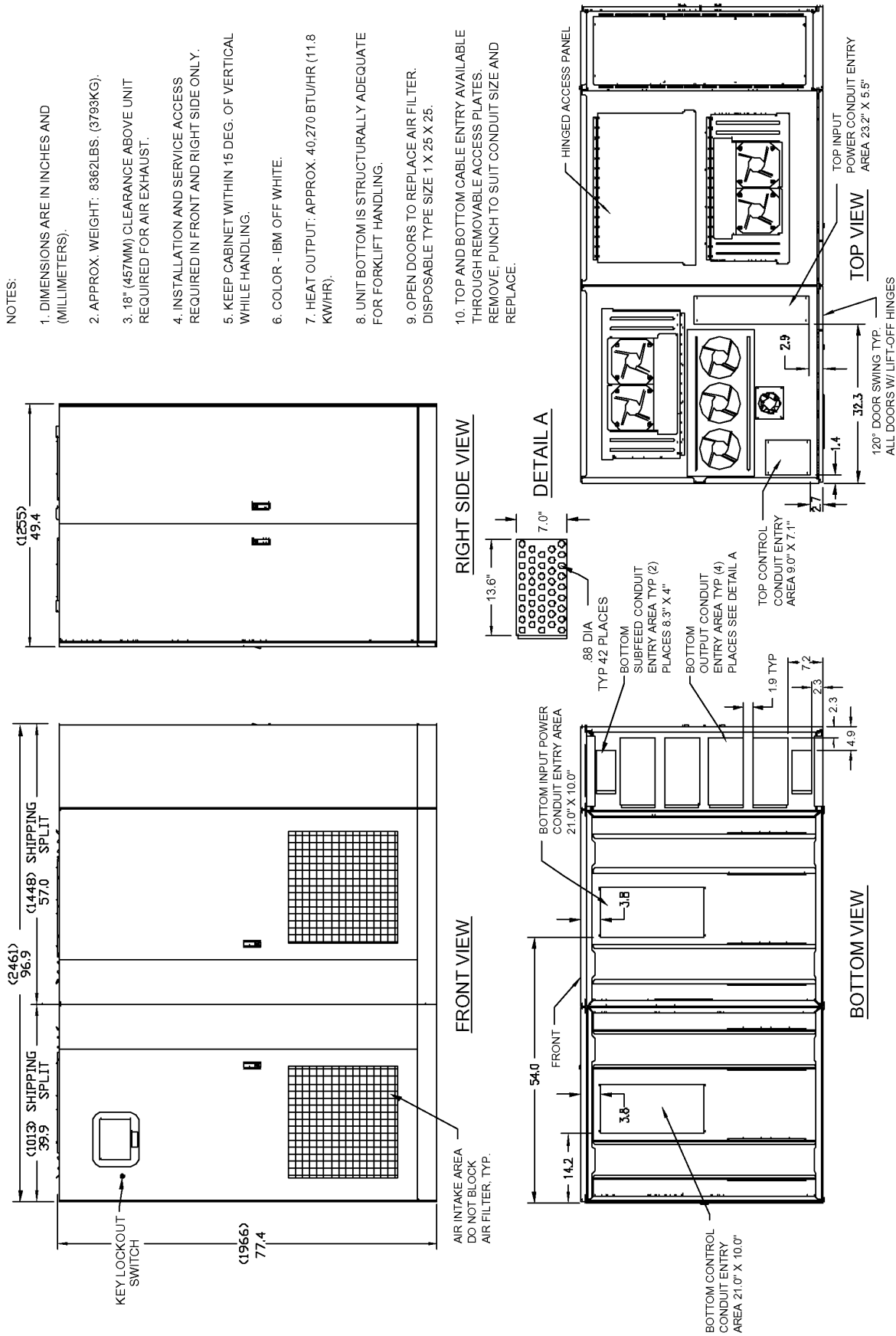

- NOTES:
1. DIMENSIONS ARE IN INCHES AND (MILLIMETERS).
 2. APPROX. WEIGHT: 8362LBS. (3793KG).
 3. 18" (457MM) CLEARANCE ABOVE UNIT REQUIRED FOR AIR EXHAUST.
 4. INSTALLATION AND SERVICE ACCESS REQUIRED IN FRONT AND RIGHT SIDE ONLY.
 5. KEEP CABINET WITHIN 15 DEG. OF VERTICAL WHILE HANDLING.
 6. COLOR - IBM OFF WHITE.
 7. HEAT OUTPUT: APPROX. 40,270 BTU/HR (11.8 KW/HR).
 8. UNIT BOTTOM IS STRUCTURALLY ADEQUATE FOR FORKLIFT HANDLING.
 9. OPEN DOORS TO REPLACE AIR FILTER. DISPOSABLE TYPE SIZE 1 X 25 X 25.
 10. TOP AND BOTTOM CABLE ENTRY AVAILABLE THROUGH REMOVABLE ACCESS PLATES. REMOVE, PUNCH TO SUIT CONDUIT SIZE AND REPLACE.

PSP11807
Rev. 0

Figure 23 Electrical field connections, 250A Liebert STS2/PDU input/output with CB8

NOTES:

1. ALL DIMENSIONS ARE IN INCHES AND (MILLIMETERS).
2. PHASE, NEUTRAL, & GROUND BUSBARS ARE 1/4" THICK.
3. CONTROL WIRING AND POWER WIRING MUST BE RUN IN SEPARATE CONDUIT. OUTPUT CABLES SHOULD BE RUN IN A SEPARATE CONDUIT FROM INPUT CABLES.
4. ALUMINUM AND COPPER CLAD ALUMINUM CABLES ARE NOT RECOMMENDED.
5. ALL WIRING IS TO BE IN ACCORDANCE WITH NATIONAL AND LOCAL ELECTRICAL CODES.

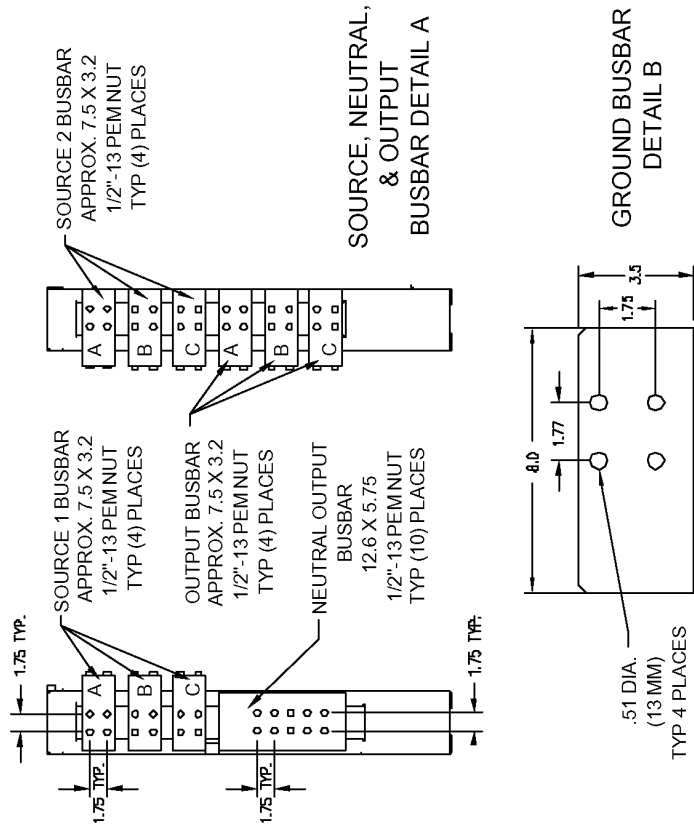
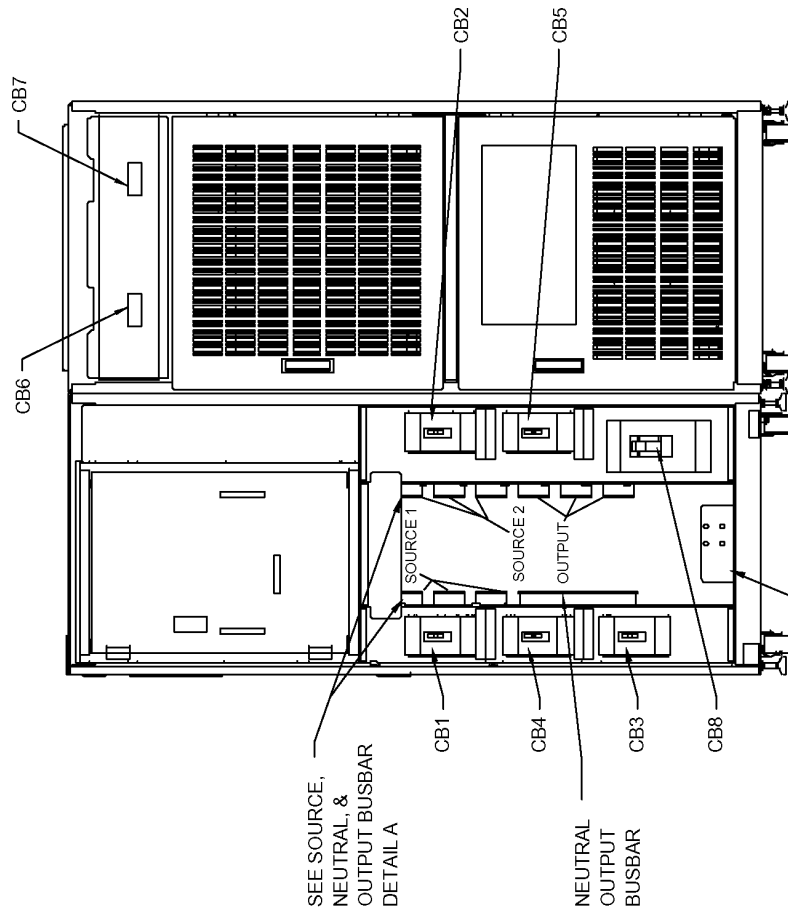

FRONT VIEW WITH DOORS & ACCENT
PANELS REMOVED

PSP11009
Rev. 0

Figure 24 Electrical field connections, 250A Liebert STS2/PDU input with CB3

NOTES:

1. ALL DIMENSIONS ARE IN INCHES AND (MILLIMETERS).
2. PHASE & GROUND BUSBARS ARE 1/4" THICK.
3. CONTROL WIRING AND POWER WIRING MUST BE RUN IN SEPARATE CONDUIT. OUTPUT CABLES SHOULD BE RUN IN A SEPARATE CONDUIT FROM INPUT CABLES.
4. ALUMINUM AND COPPER CLAD ALUMINUM CABLES ARE NOT RECOMMENDED.
5. ALL WIRING IS TO BE IN ACCORDANCE WITH NATIONAL AND LOCAL ELECTRICAL CODES.

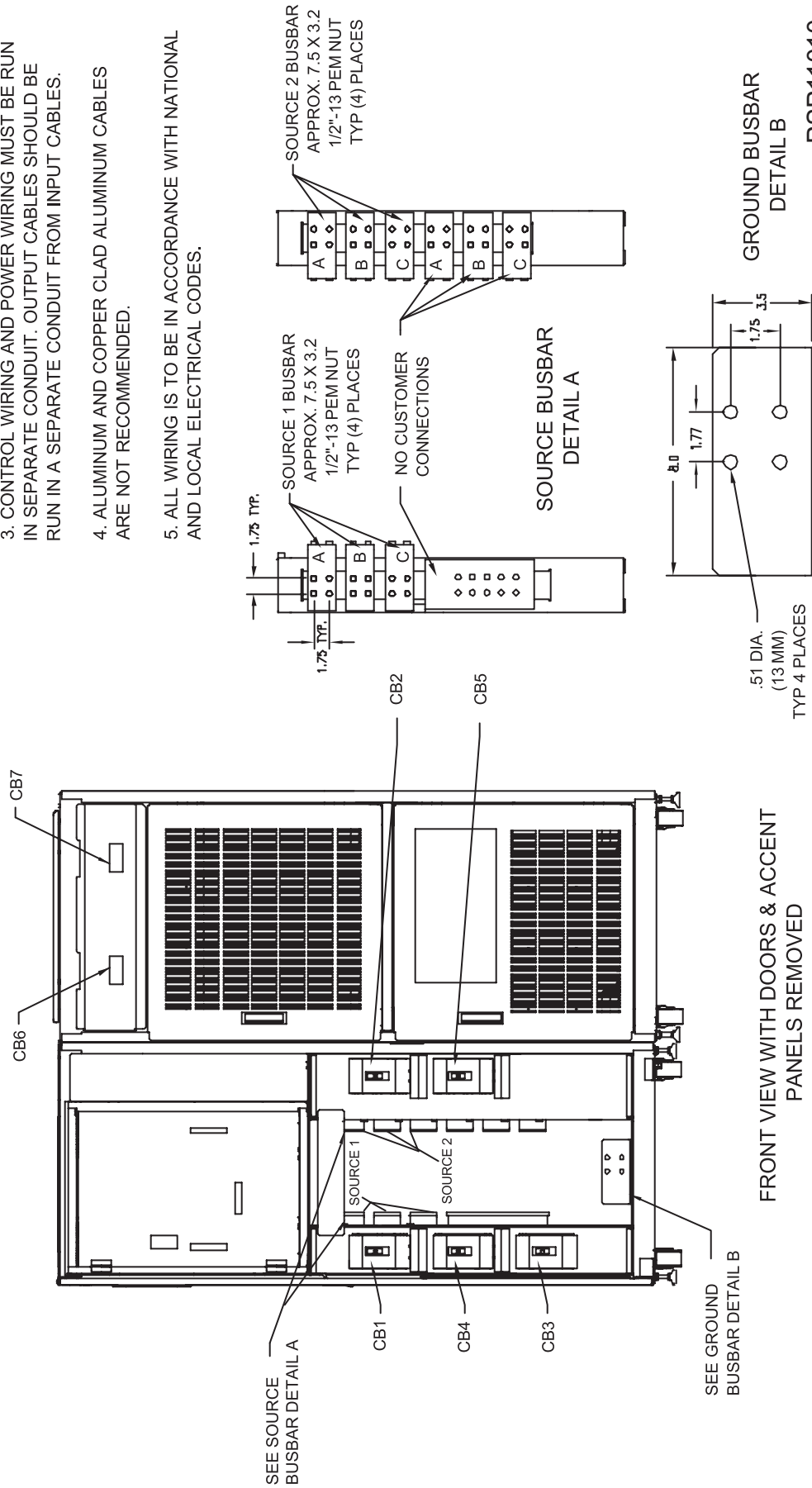

PSP11010
Rev. 01

Figure 25 Electrical field connections, 250A Liebert STS2/PDU input with CB3 & CB3A

NOTES:

1. ALL DIMENSIONS ARE IN INCHES AND (MILLIMETERS).
2. PHASE & GROUND BUSBARS ARE 1/4" THICK.
3. CONTROL WIRING AND POWER WIRING MUST BE RUN IN SEPARATE CONDUIT. OUTPUT CABLES SHOULD BE RUN IN A SEPARATE CONDUIT FROM INPUT CABLES.
4. ALUMINUM AND COPPER CLAD ALUMINUM CABLES ARE NOT RECOMMENDED.
5. ALL WIRING IS TO BE IN ACCORDANCE WITH NATIONAL AND LOCAL ELECTRICAL CODES.

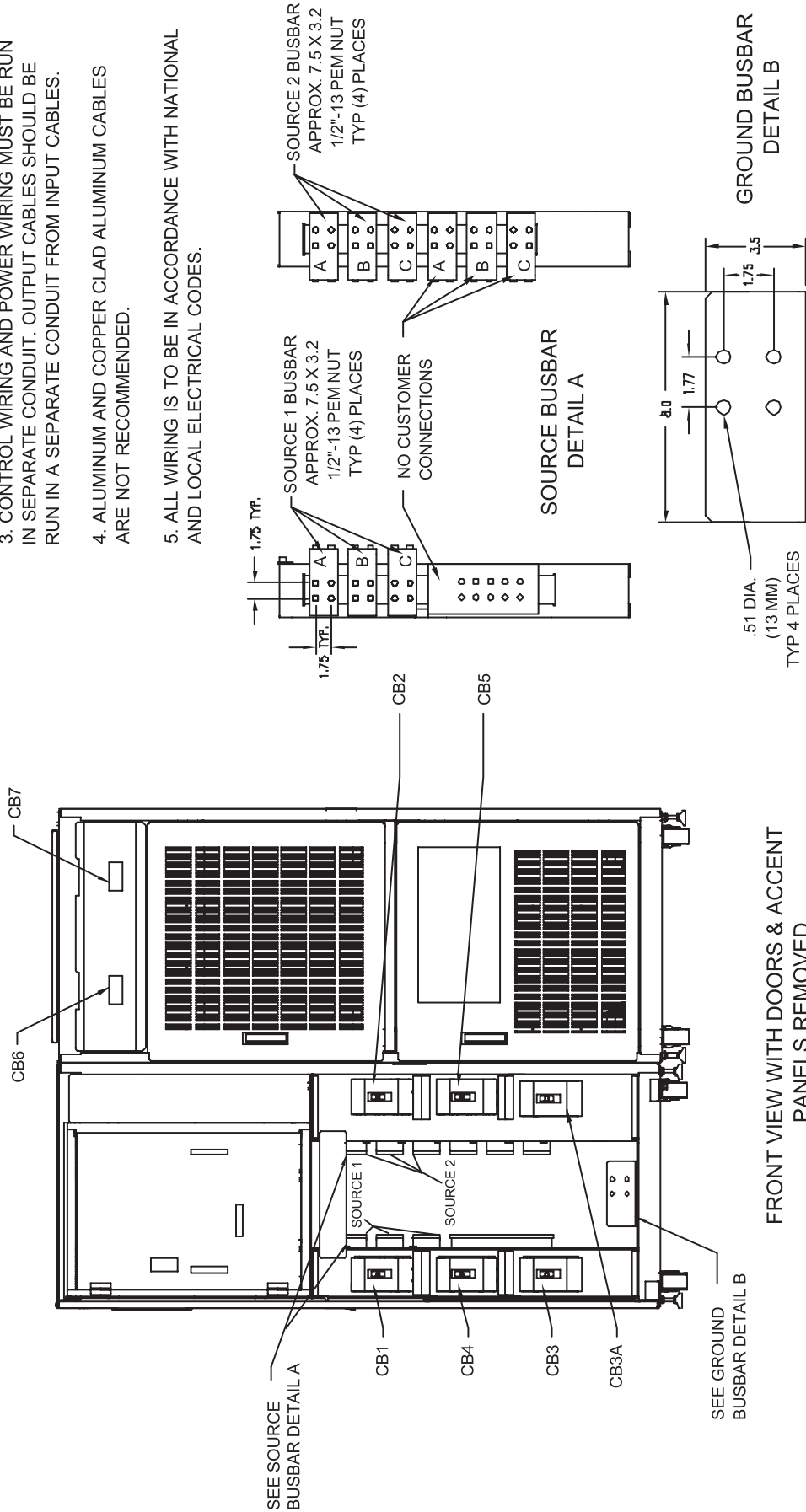

PSP11011
Rev. 01

Figure 26 Electrical field connections, 400-600A Liebert STS2/PDU input with CB3

NOTES:

1. ALL DIMENSIONS ARE IN INCHES AND (MILLIMETERS).
2. PHASE AND GROUND BUSBARS ARE 1/4" THICK.
3. CONTROL WIRING AND POWER WIRING MUST BE RUN IN SEPARATE CONDUIT. OUTPUT CABLES SHOULD BE RUN IN A SEPARATE CONDUIT FROM INPUT CABLES.
4. ALUMINUM AND COPPER CLAD ALUMINUM CABLES ARE NOT RECOMMENDED.
5. ALL WIRING IS TO BE IN ACCORDANCE WITH NATIONAL AND LOCAL ELECTRICAL CODES.

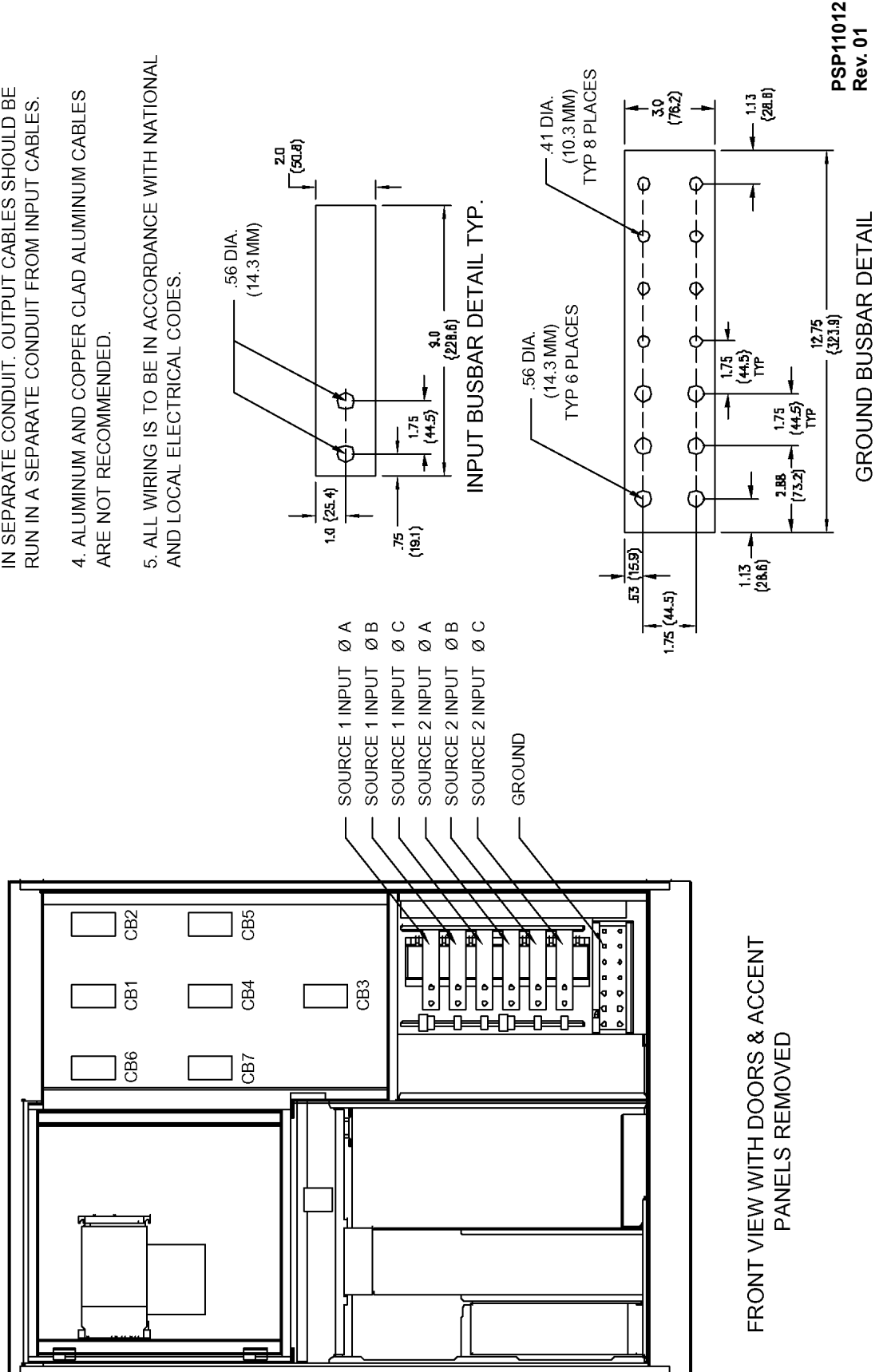

PSP11012
Rev. 01

Figure 27 Electrical field connections, 400-600A Liebert STS2/PDU input with CB3 and CB3A

NOTES:

1. ALL DIMENSIONS ARE IN INCHES AND (MILLIMETERS).
2. PHASE AND GROUND BUSBARS ARE 1/4" THICK.
3. CONTROL WIRING AND POWER WIRING MUST BE RUN IN SEPARATE CONDUIT. OUTPUT CABLES SHOULD BE RUN IN A SEPARATE CONDUIT FROM INPUT CABLES.
4. ALUMINUM AND COPPER CLAD ALUMINUM CABLES ARE NOT RECOMMENDED.
5. ALL WIRING IS TO BE IN ACCORDANCE WITH NATIONAL AND LOCAL ELECTRICAL CODES.

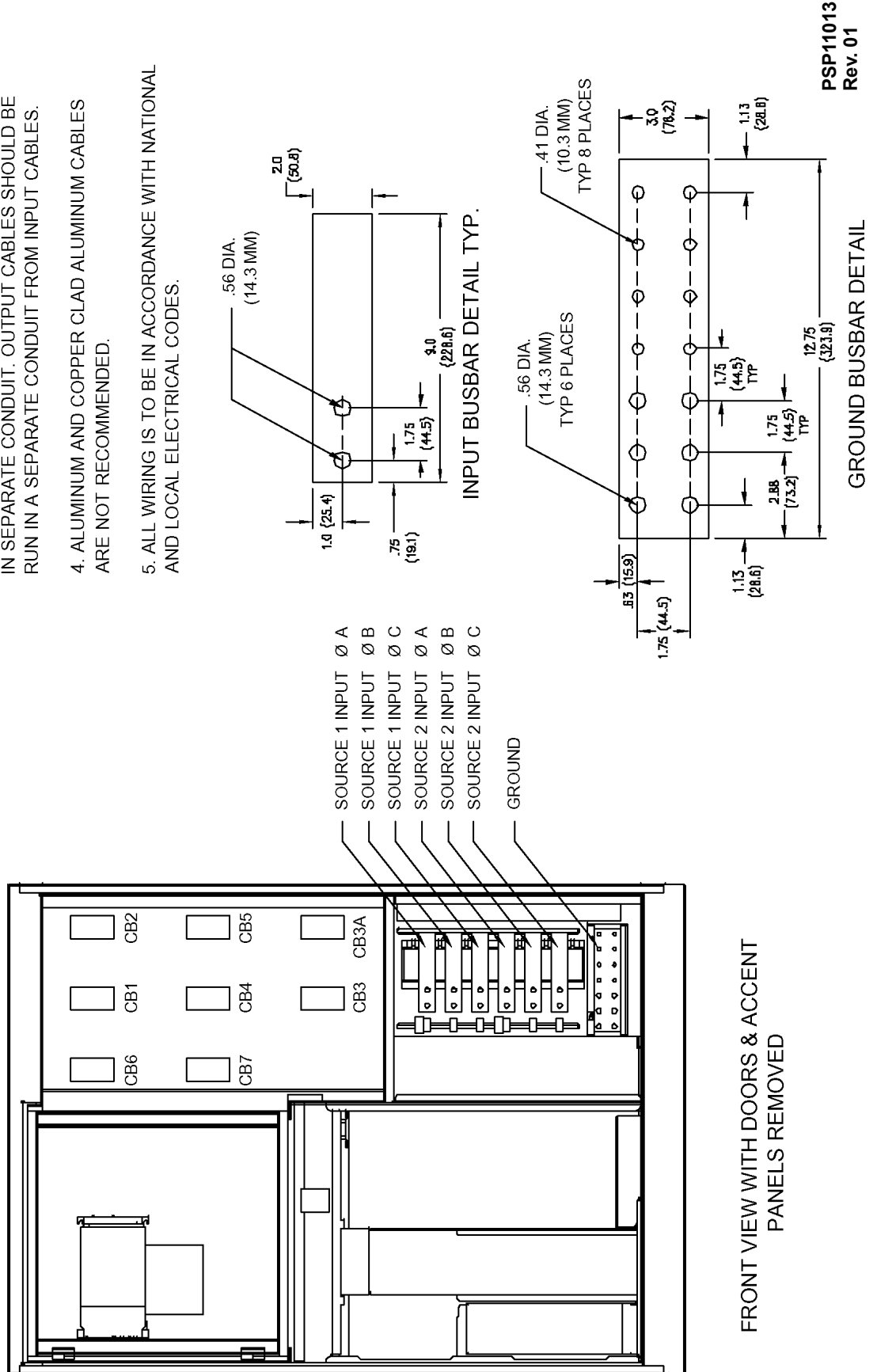
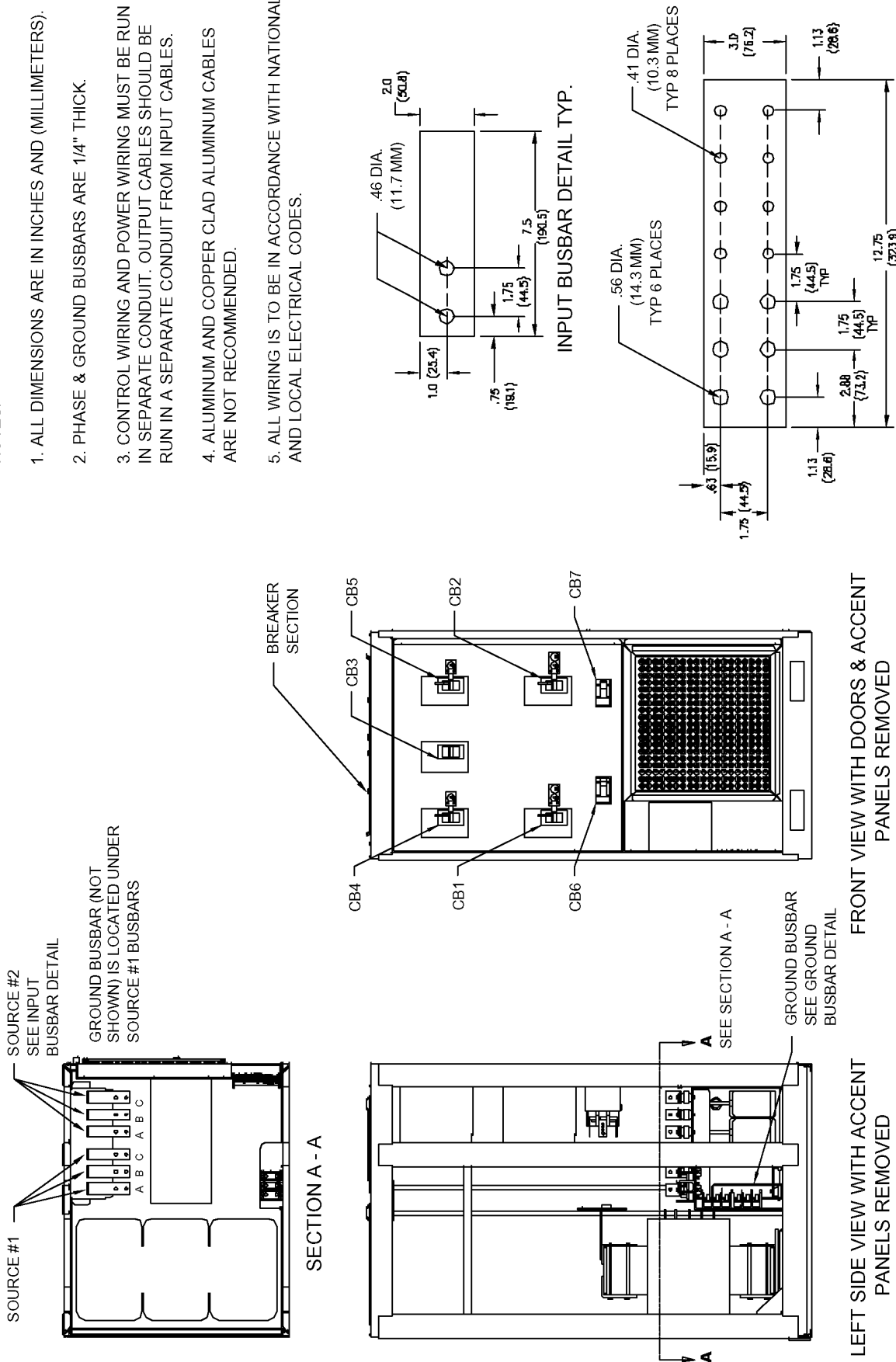

Figure 28 Electrical field connections, 800A Liebert STS2/PDU input with CB3

NOTES:

1. ALL DIMENSIONS ARE IN INCHES AND (MILLIMETERS).
2. PHASE & GROUND BUSBARS ARE 1/4" THICK.
3. CONTROL WIRING AND POWER WIRING MUST BE RUN IN SEPARATE CONDUIT. OUTPUT CABLES SHOULD BE RUN IN A SEPARATE CONDUIT FROM INPUT CABLES.
4. ALUMINUM AND COPPER CLAD ALUMINUM CABLES ARE NOT RECOMMENDED.
5. ALL WIRING IS TO BE IN ACCORDANCE WITH NATIONAL AND LOCAL ELECTRICAL CODES.



PSP11014
Rev. 0

Figure 29 Electrical field connections, 800A Liebert STS2/PDU input with CB3 and CB3A

NOTES:

1. ALL DIMENSIONS ARE IN INCHES AND (MILLIMETERS).
2. PHASE & GROUND BUSBARS ARE 1/4" THICK.
3. CONTROL WIRING AND POWER WIRING MUST BE RUN IN SEPARATE CONDUIT. OUTPUT CABLES SHOULD BE RUN IN A SEPARATE CONDUIT FROM INPUT CABLES.
4. ALUMINUM AND COPPER CLAD ALUMINUM CABLES ARE NOT RECOMMENDED.
5. ALL WIRING IS TO BE IN ACCORDANCE WITH NATIONAL AND LOCAL ELECTRICAL CODES.

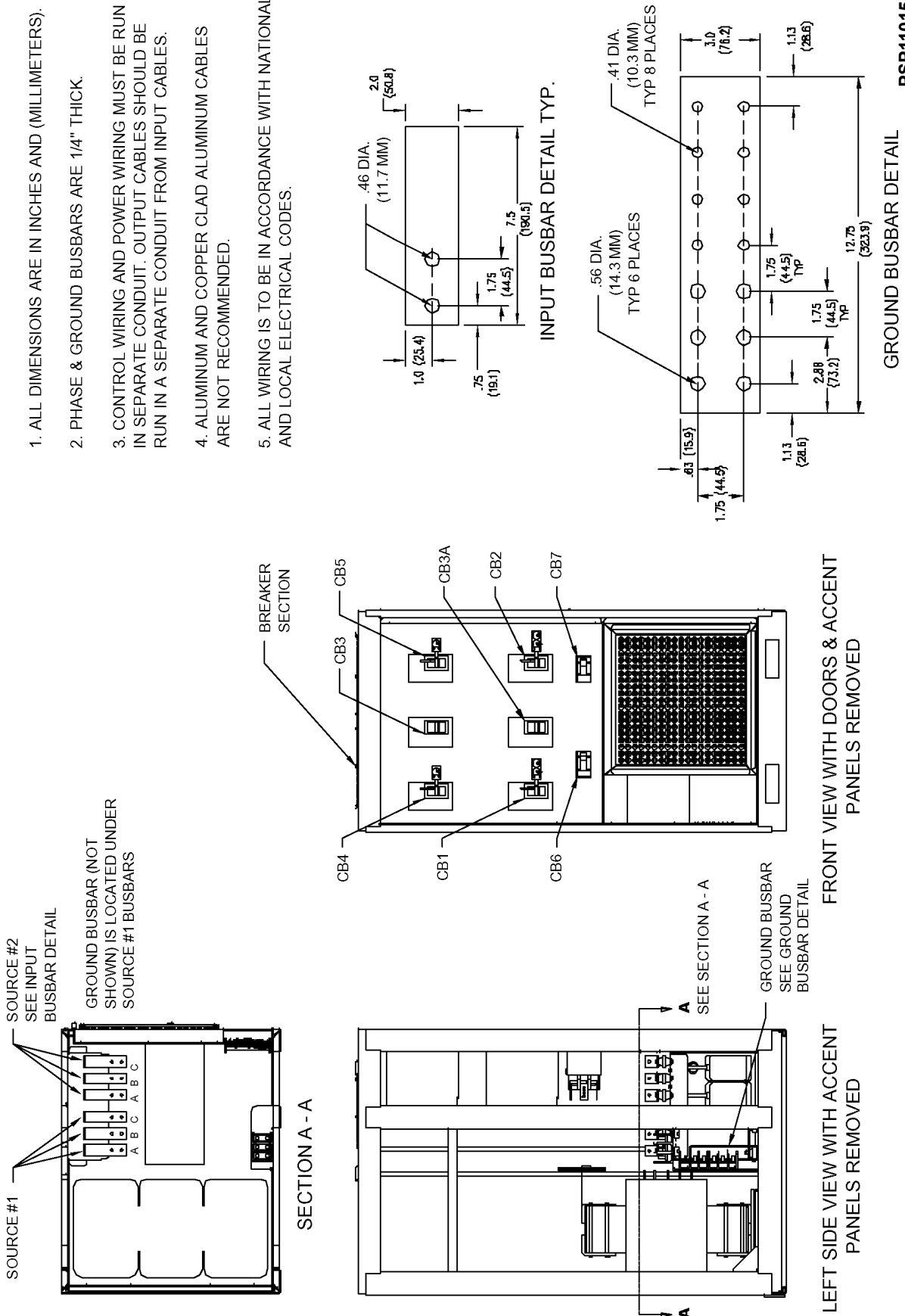

PSP11015
Rev. 0

Figure 30 Electrical field connections, 250A Liebert STS2/PDU output with inline panelboards

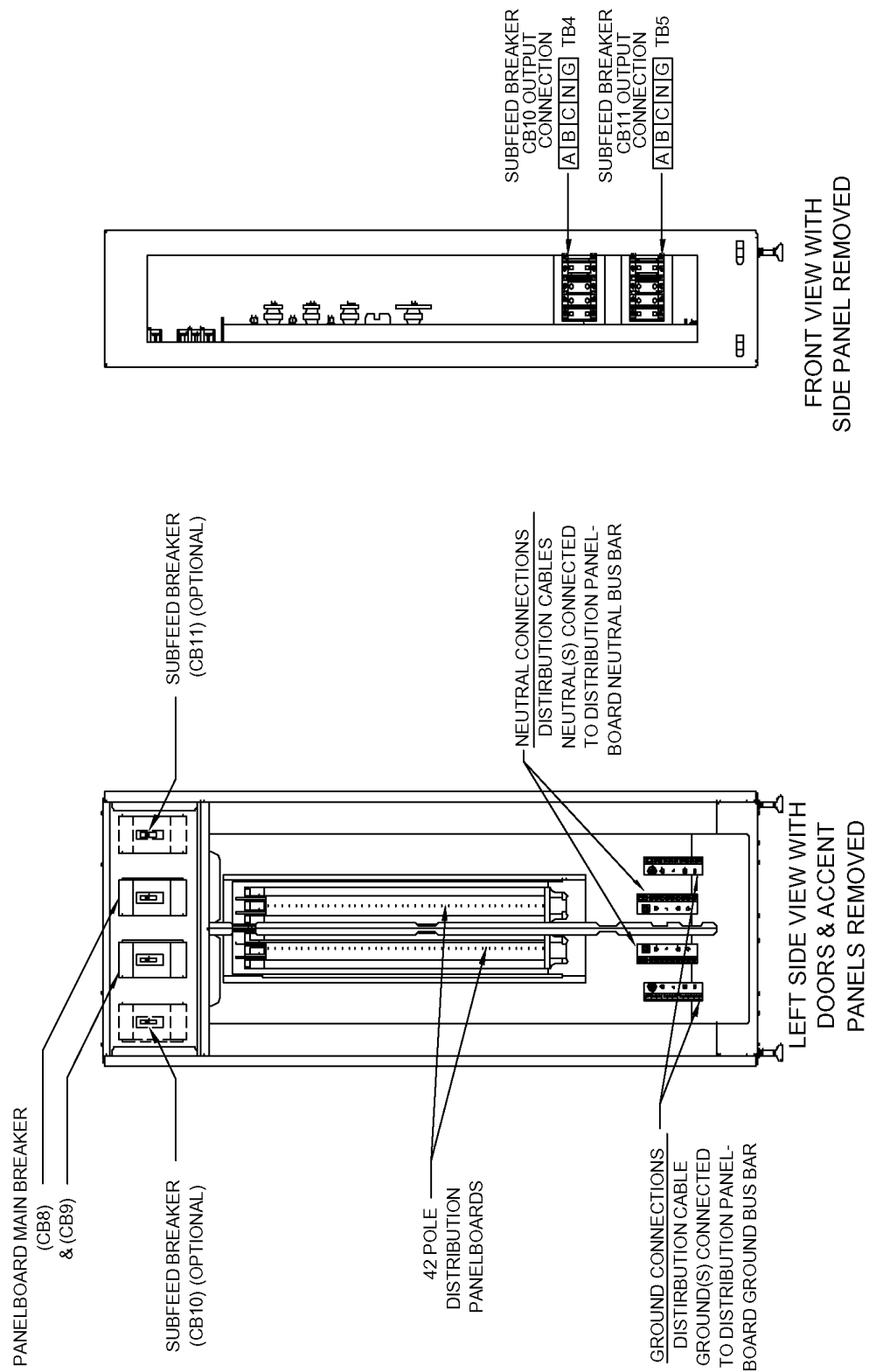

PSP11003
Rev. 0

Figure 31 Electrical field connections, 400-800A Liebert STS2/PDU output with inline panelboards

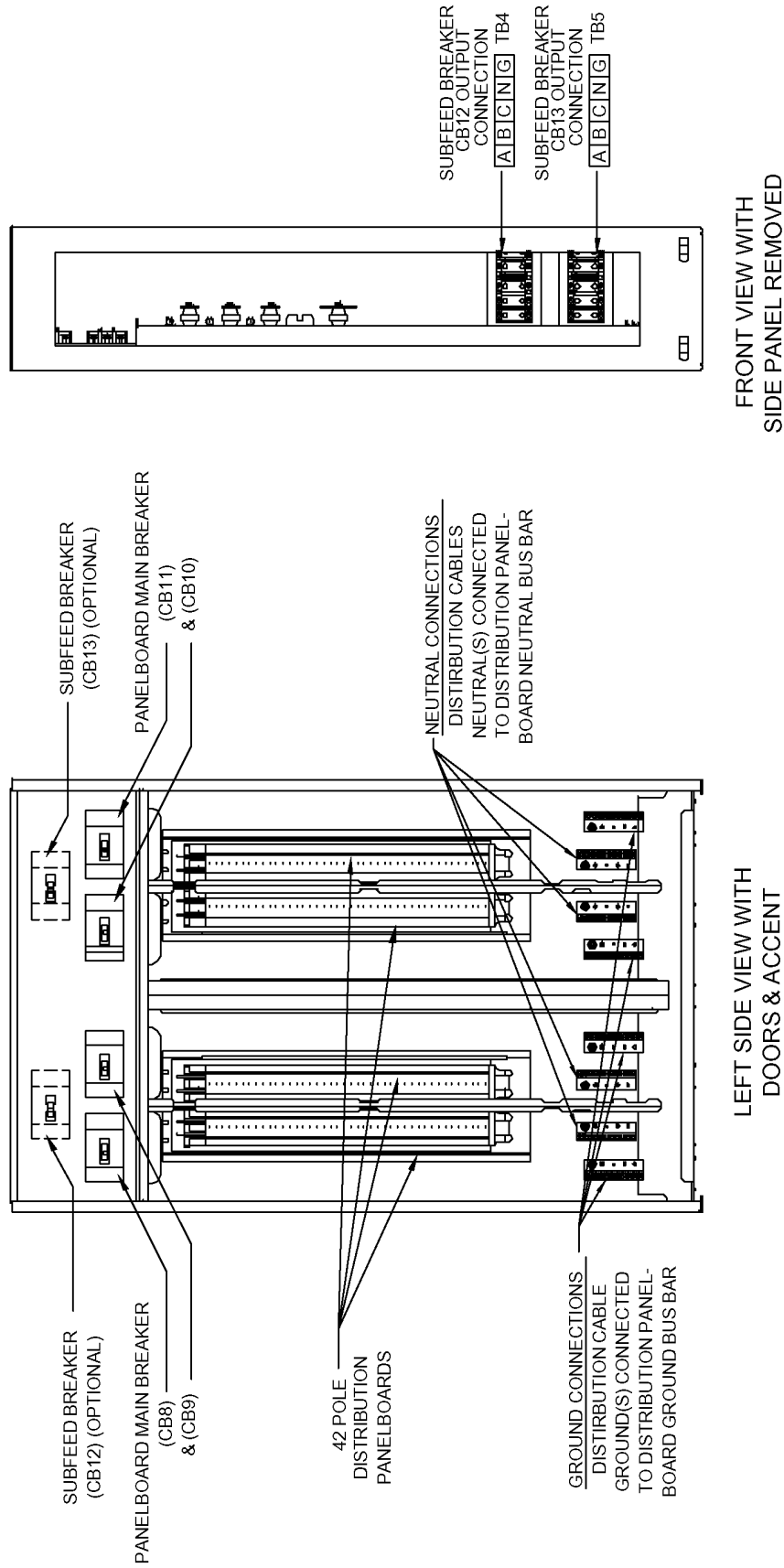

PSP11000
Rev. 02

Figure 32 Electrical field connections, Liebert STS2/PDU output with I-Line panelboard

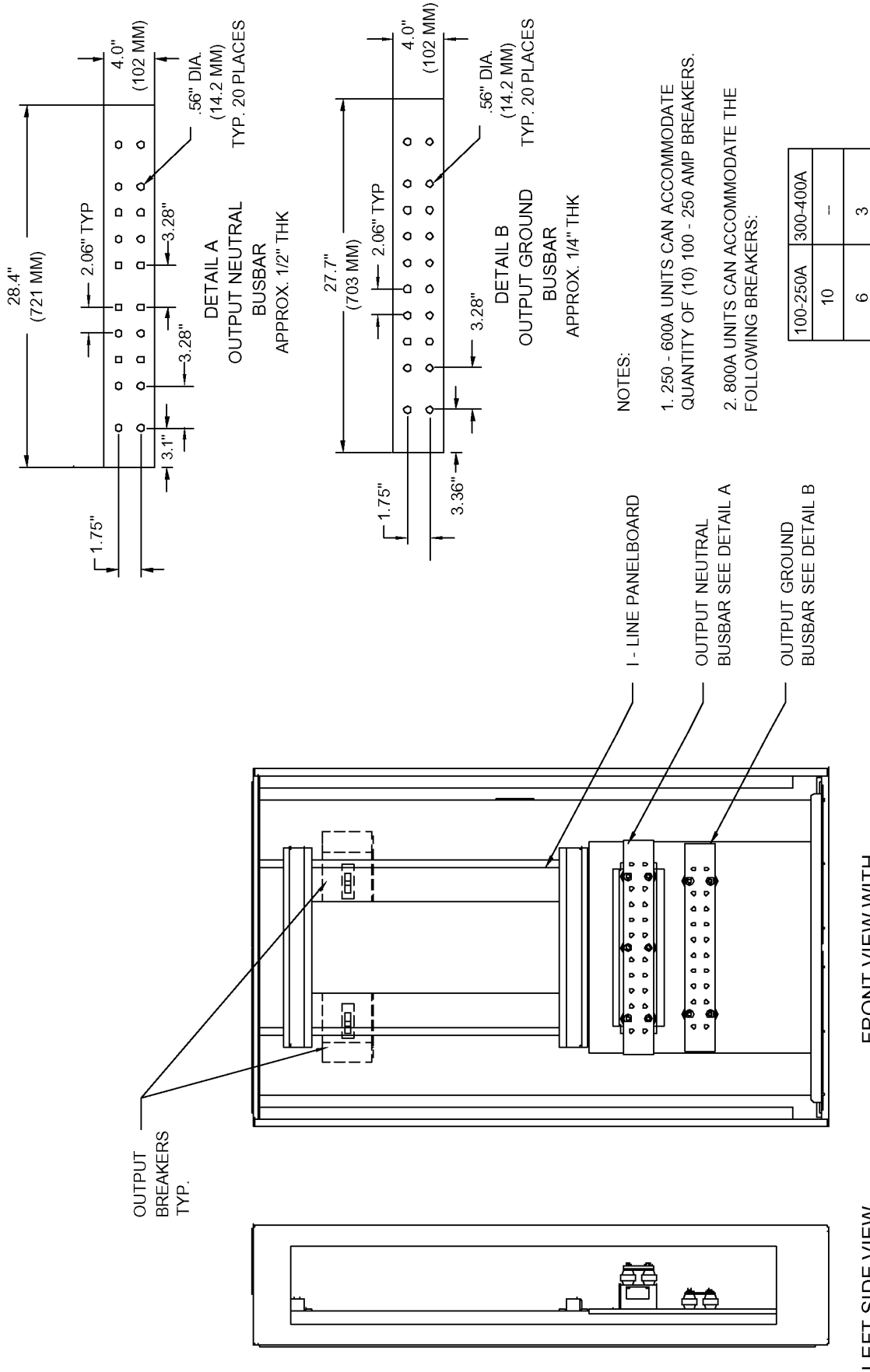

PSP11001
Rev. 02

Figure 33 Electrical field connections, 400-600A Liebert STS2/PDU with right side output breaker

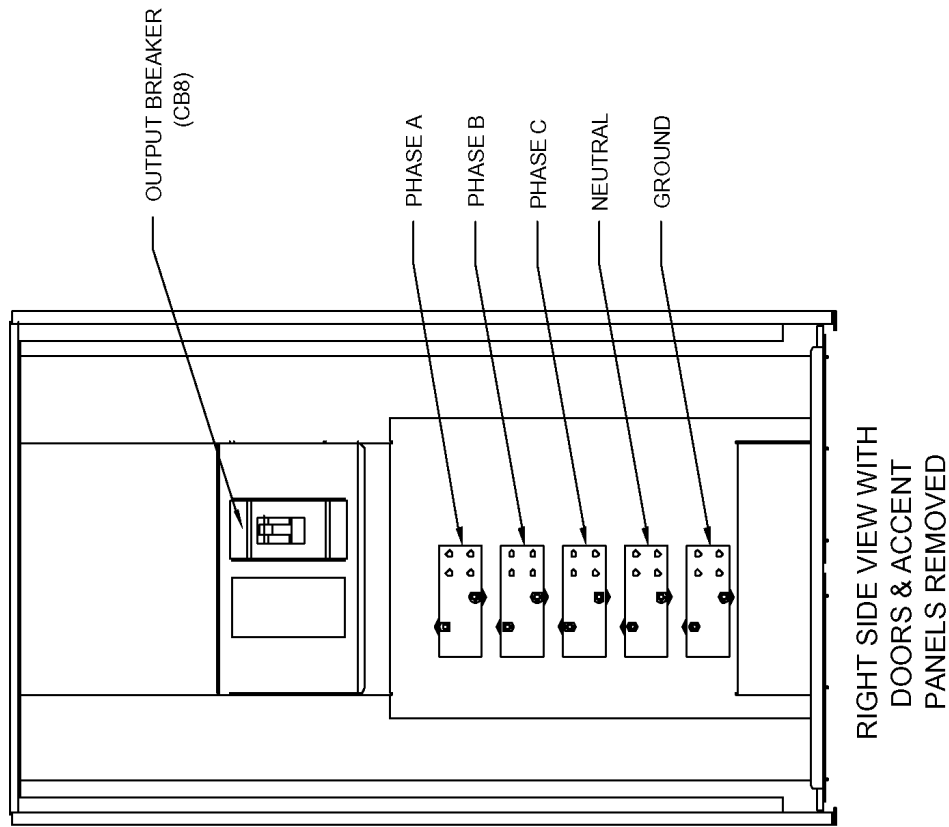
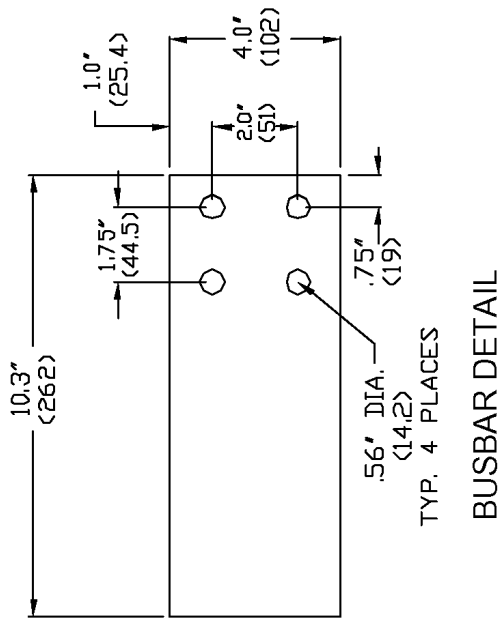

NOTES:

1. DIMENSIONS ARE IN INCHES (MILLIMETERS).
2. PHASE AND GROUND BUSBARS ARE 1/4" THICK.
3. NEUTRAL BUSBAR IS 1/2" THICK.

PSP11004
Rev. 01

Figure 34 Electrical field connections, 400-600A Liebert STS2/PDU with left side output breaker

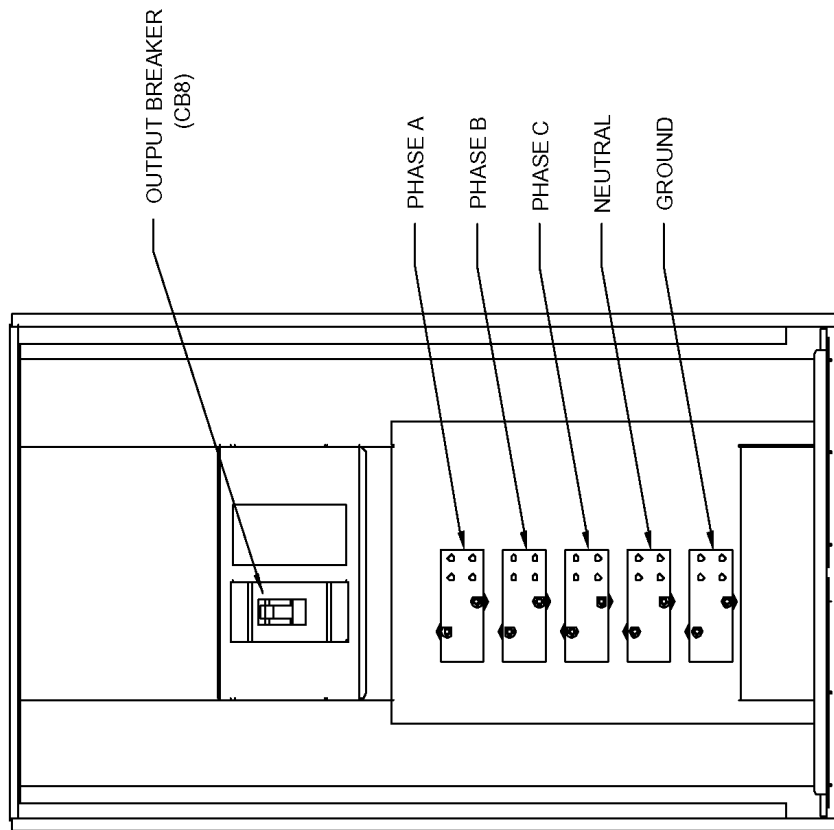
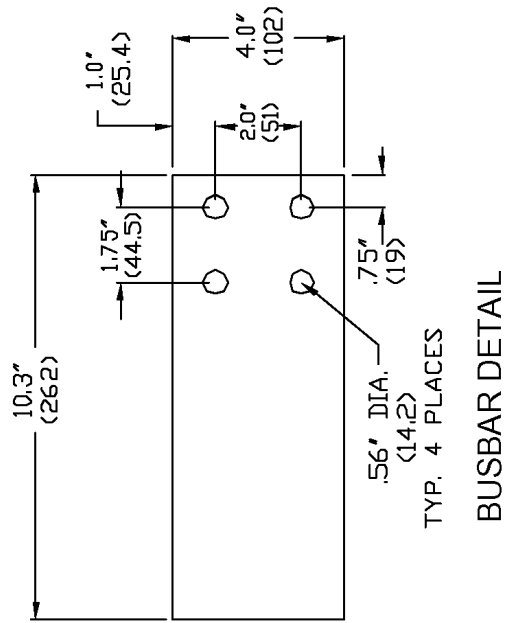

LEFT SIDE VIEW WITH
DOORS & ACCENT
PANELS REMOVED

NOTES:

1. DIMENSIONS ARE IN INCHES (MILLIMETERS).
2. PHASE AND GROUND BUSBARS ARE 1/4" THICK.
3. NEUTRAL BUSBAR IS 1/2" THICK.

PSP11005
Rev. 01

Figure 35 Electrical field connections, 800A Liebert STS2/PDU with right side output breaker

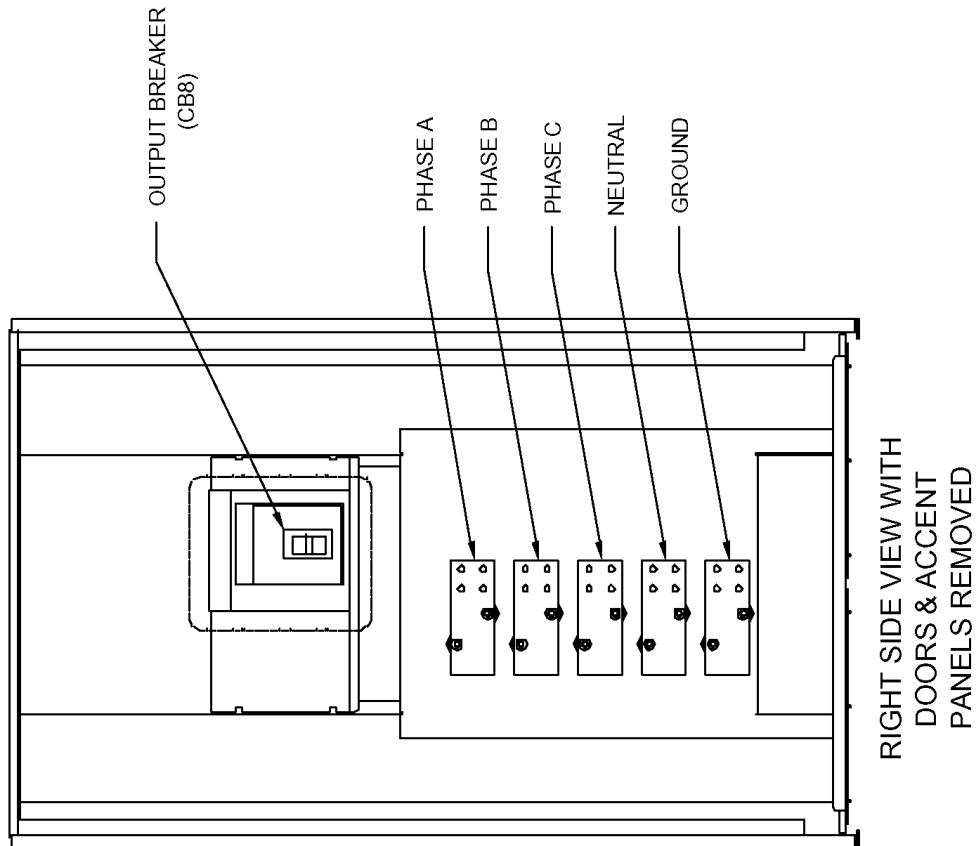
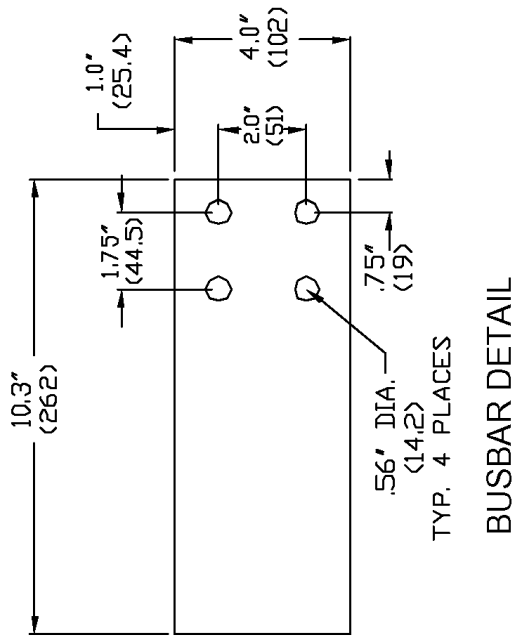

- NOTES:
1. DIMENSIONS ARE IN INCHES (MILLIMETERS).
 2. PHASE AND GROUND BUSBARS ARE 1/4" THICK.
 3. NEUTRAL BUSBAR IS 1/2" THICK.

PSP11006
Rev. 0

Figure 36 Electrical field connections, 8600A Liebert STS2/PDU with left side output breaker

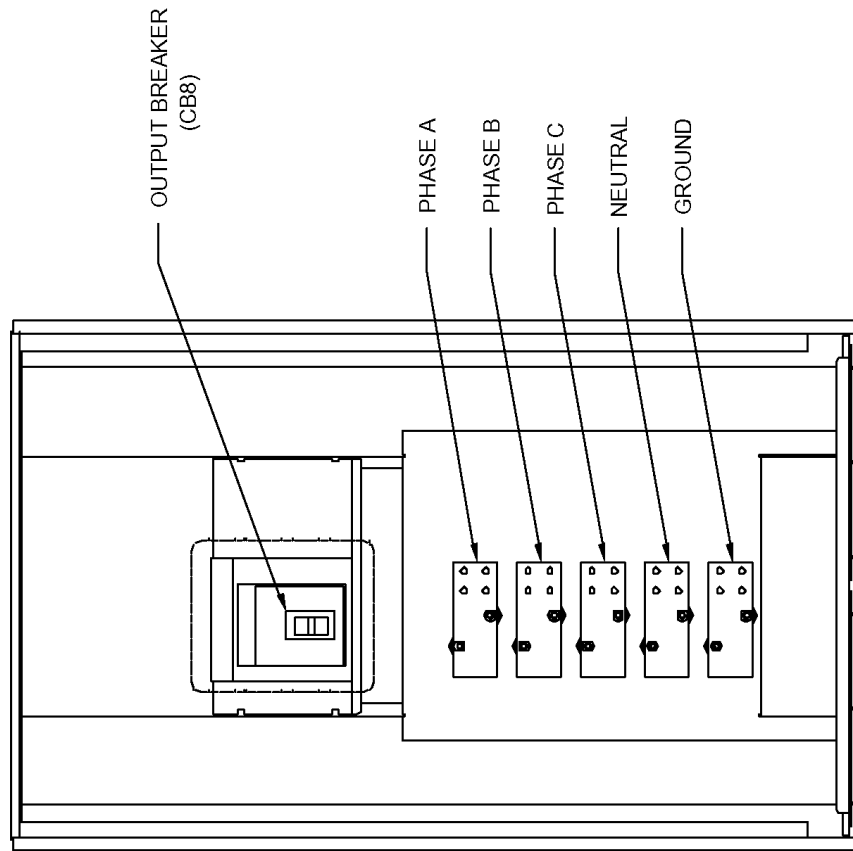
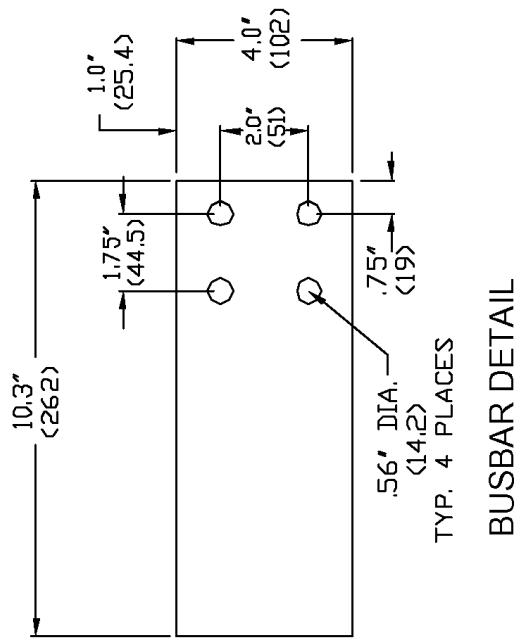

NOTES:

1. DIMENSIONS ARE IN INCHES (MILLIMETERS).
2. PHASE AND GROUND BUSBARS ARE 1/4" THICK.
3. NEUTRAL BUSBAR IS 1/2" THICK.

PSP11007
Rev. 0

Figure 37 Electrical field connections, 800A Liebert STS2/PDU interconnect wiring

NOTES:

1. ALL DIMENSIONS ARE IN INCHES AND (MILLIMETERS).
2. NEUTRAL & GROUND BUSBARS ARE 1/4" THICK.
3. ALL INTERCONNECTION WIRING FACTORY SUPPLIED.

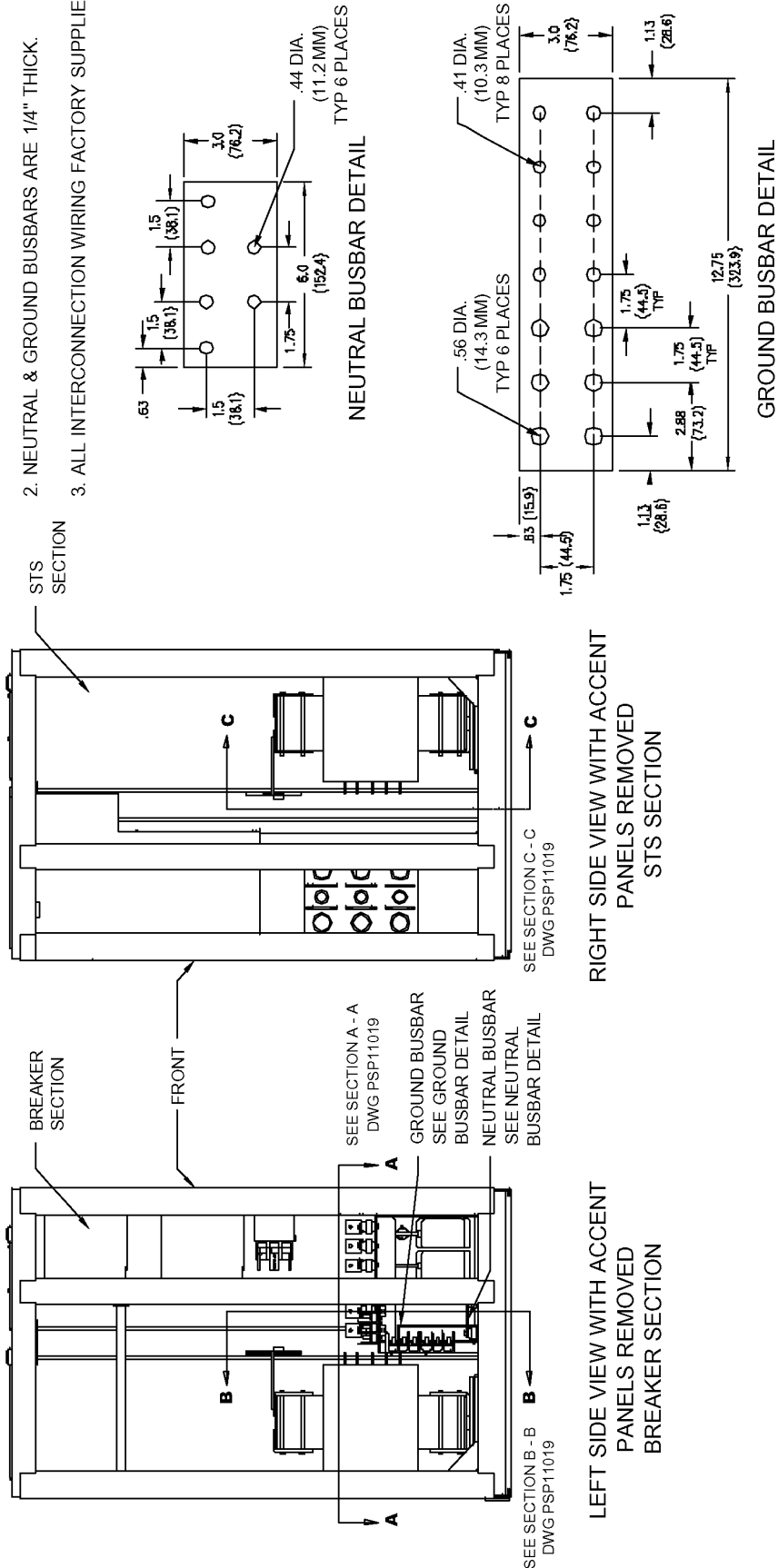

PSP11018
Rev. 0

Figure 38 Electrical field connections, 800A Liebert STS2/PDU interconnect wiring, breaker section

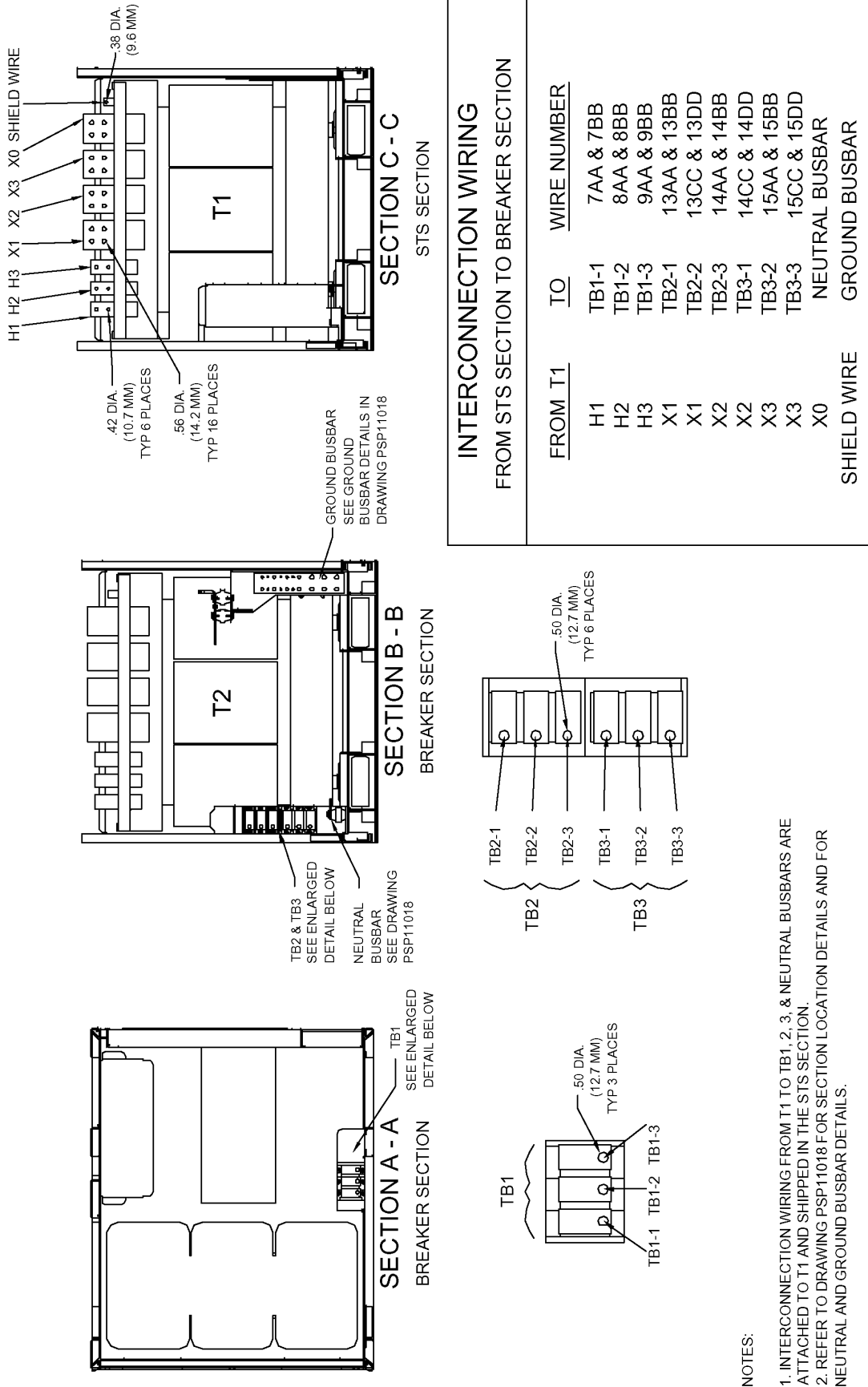

PSP11019
Rev. 0

NOTES:
1. INTERCONNECTION WIRING FROM T1 TO TB1, 2, 3, & NEUTRAL BUSBARS ARE ATTACHED TO T1 AND SHIPPED IN THE STS SECTION.
2. REFER TO DRAWING PSP11018 FOR SECTION LOCATION DETAILS AND FOR NEUTRAL AND GROUND BUSBAR DETAILS.

Figure 39 Electrical field connections, 800A Liebert STS2/PDU interconnect wiring, STS section

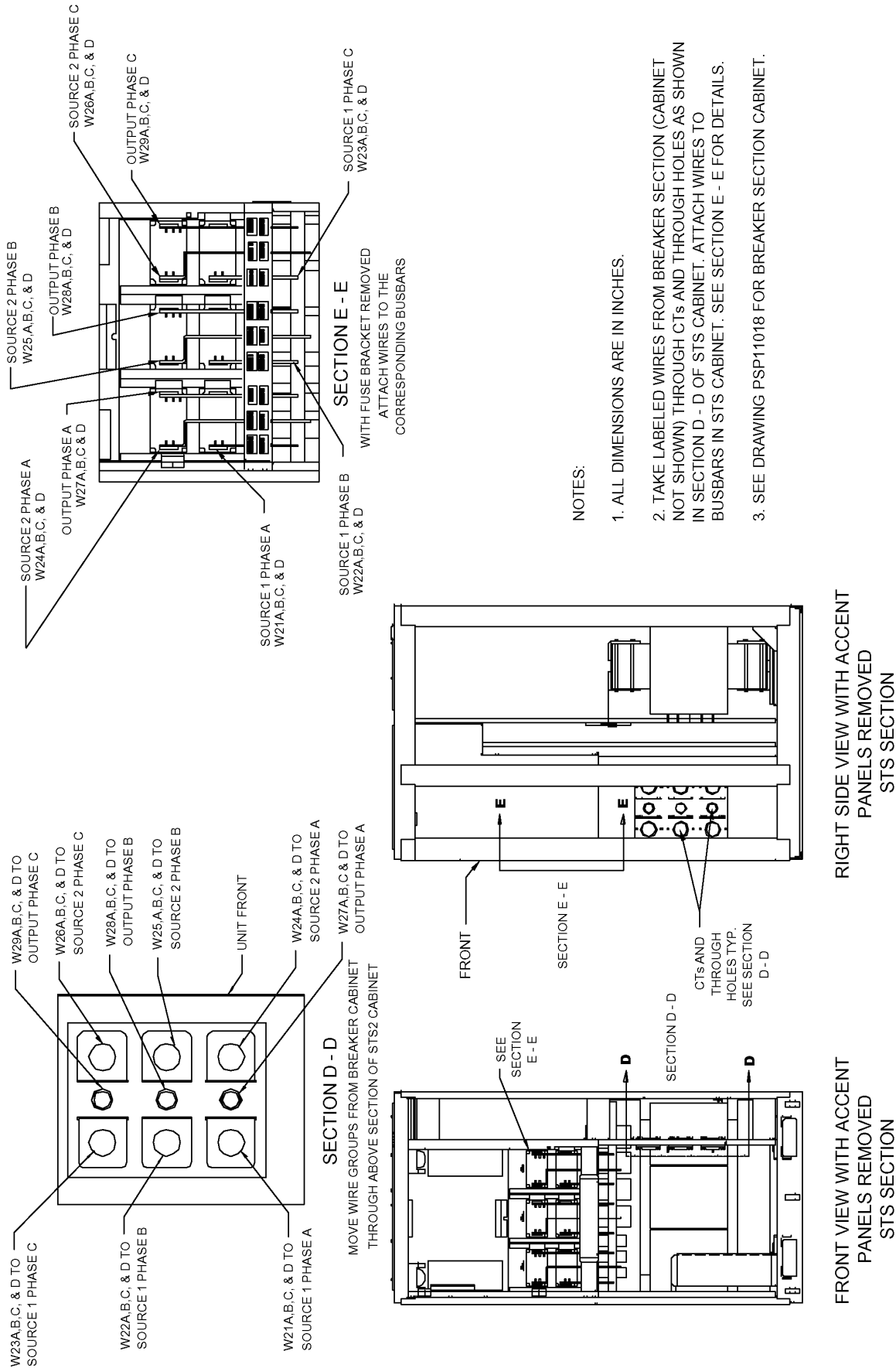

PSP11020
Rev. 0

Figure 40 Electrical field connections, 800A Liebert STS2/PDU interconnect wiring, left side distribution cabinet

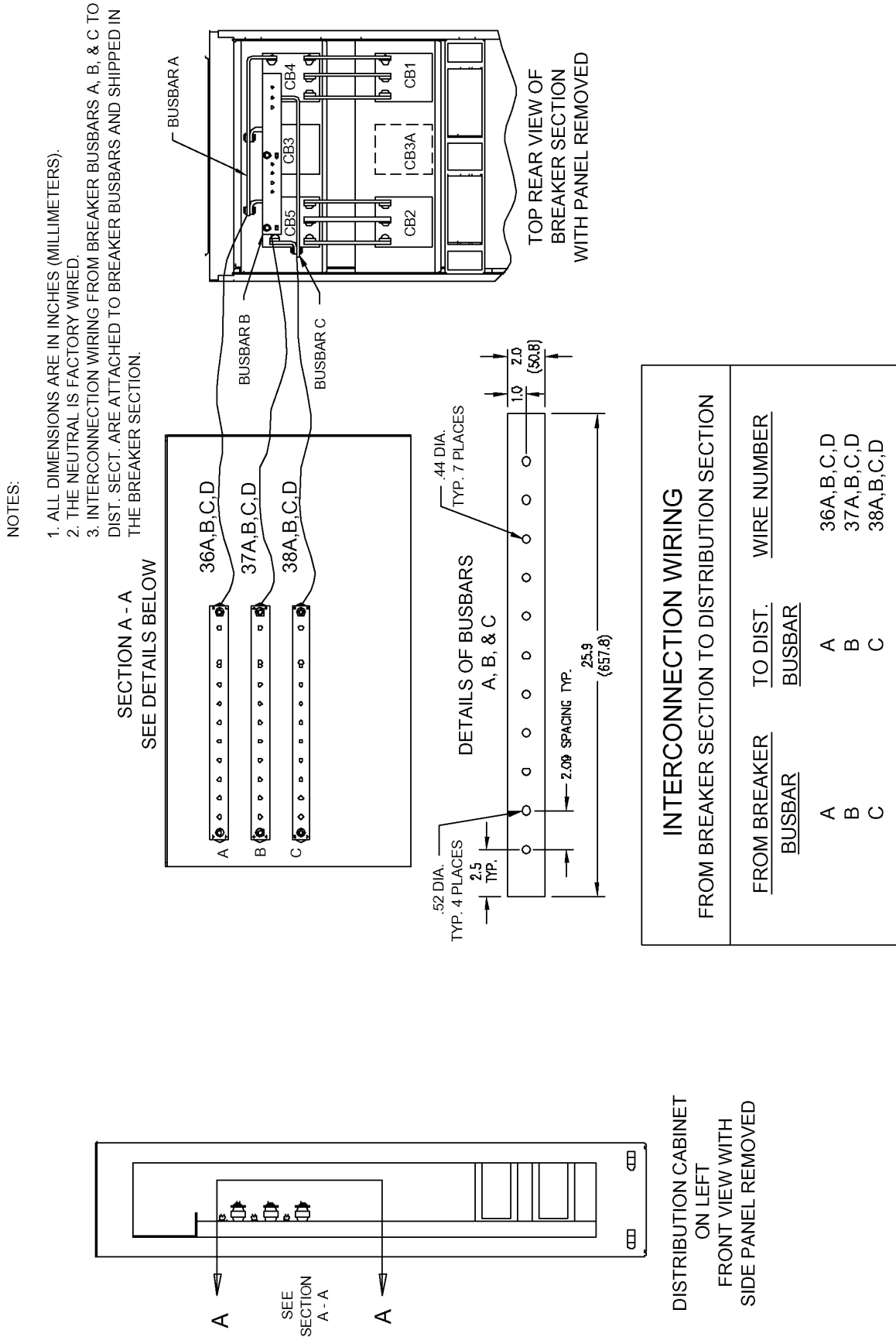

PSP11021
Rev. 0

Figure 41 Electrical field connections, 800A Liebert STS2/PDU interconnect wiring, left side one-line

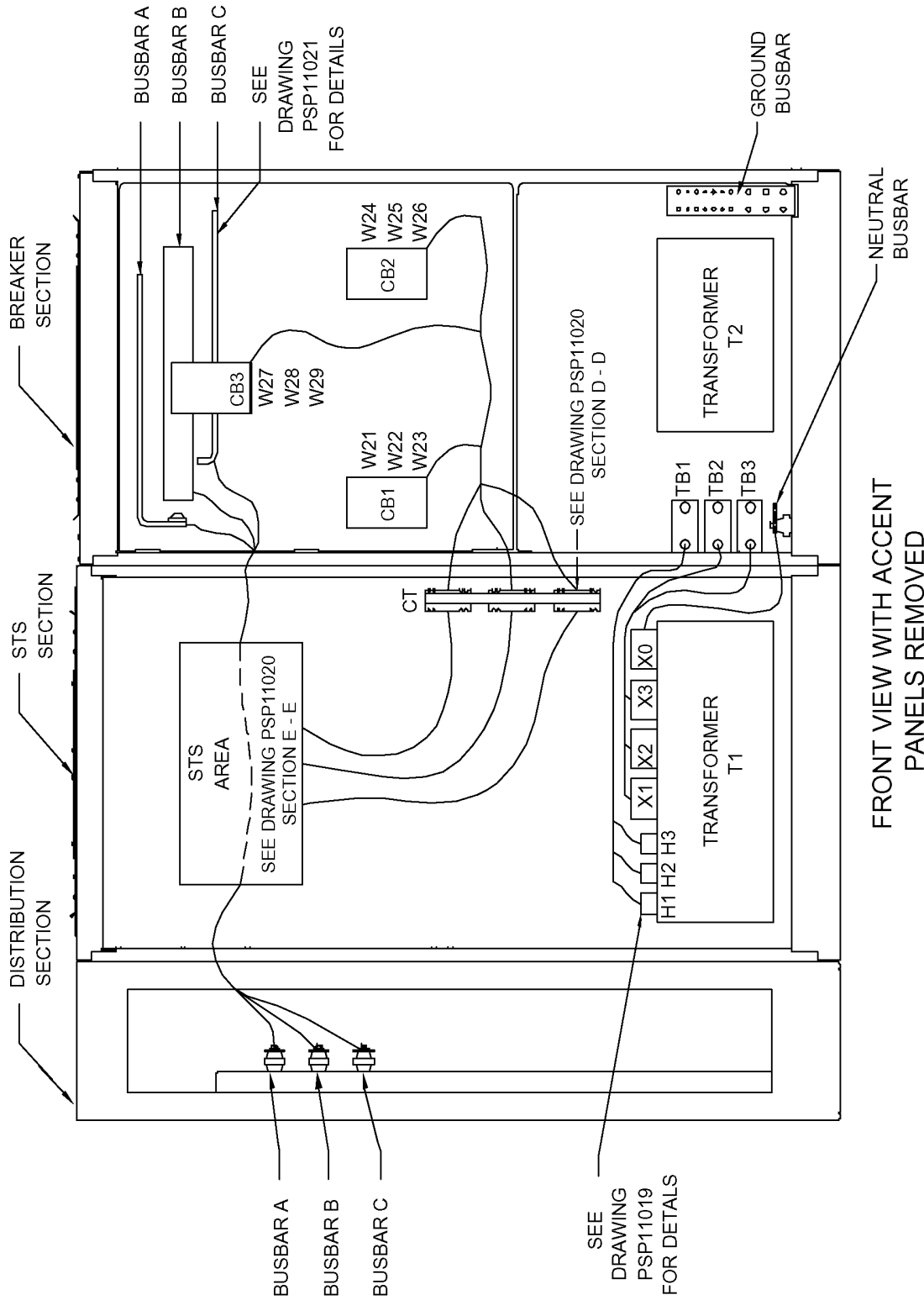

NOTES:

1. INTERCONNECTION WIRING FROM T1 TO TB1, 2, 3, & NEUTRAL BUSBARS ARE ATTACHED TO T1 AND SHIPPED IN THE STS SECTION. SEE DRAWING PSP11019 FOR DETAILS.
2. INTERCONNECTION WIRING FROM CB1, CB2, & CB3 TO STS SECT. ARE ATTACHED TO CB1, CB2, & CB3 AND SHIPPED IN THE BREAKER SECT. SEE DWG PSP11020 FOR DETAILS.
3. INTERCONNECTION WIRING FROM BRKR. BUSBARS A, B, & C TO DIST. SECT. ARE ATTACHED TO BRKR. BUSBARS AND SHIPPED IN THE BRKR. SECT. SEE DWG PSP11021 FOR DETAILS.

PSP11024
Rev. 0

Figure 42 Electrical field connections, 800A Liebert STS2/PDU interconnect wiring, left side one-line with CB3A

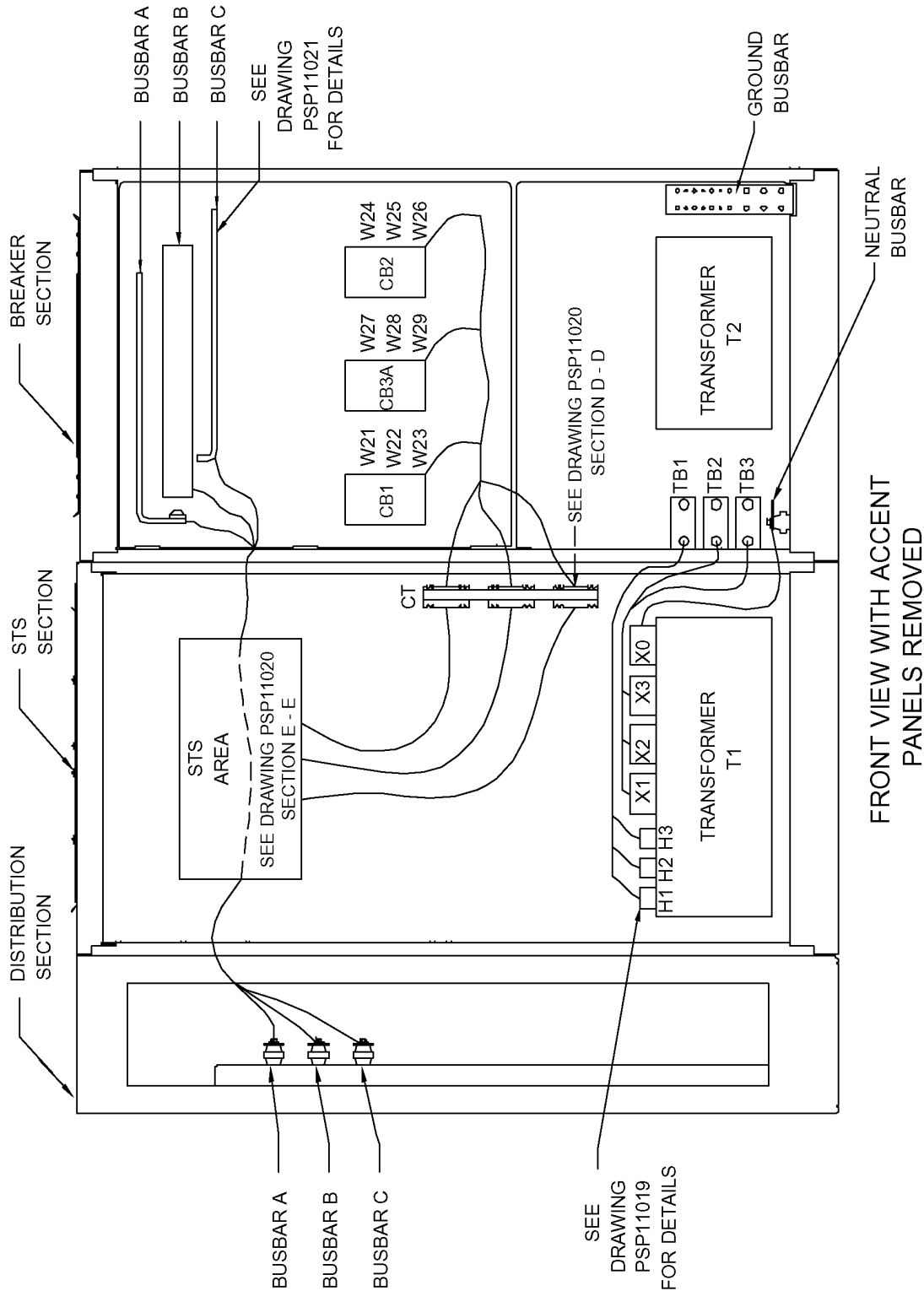

PSP11025
Rev. 0

NOTES:

1. INTERCONNECTION WIRING FROM T1 TO TB1, 2, 3, & NEUTRAL BUSBARS ARE ATTACHED TO T1 AND SHIPPED IN THE STS SECTION. SEE DRAWING PSP11019 FOR DETAILS.
2. INTERCONNECTION WIRING FROM CB1, CB2, & CB3A TO STS SECT. ARE ATTACHED TO CB1, CB2, & CB3A AND SHIPPED IN THE BREAKER SECT. SEE DWG PSP11020 FOR DETAILS.
3. INTERCONNECTION WIRING FROM BRKR. BUSBARS A, B, & C TO DIST. SECT. ARE ATTACHED TO BRKR. BUSBARS AND SHIPPED IN THE BRKR. SECT. SEE DWG PSP11021 FOR DETAILS.

Figure 43 Electrical field connections, 800A Liebert STS2/PDU interconnect wiring, right side one-line

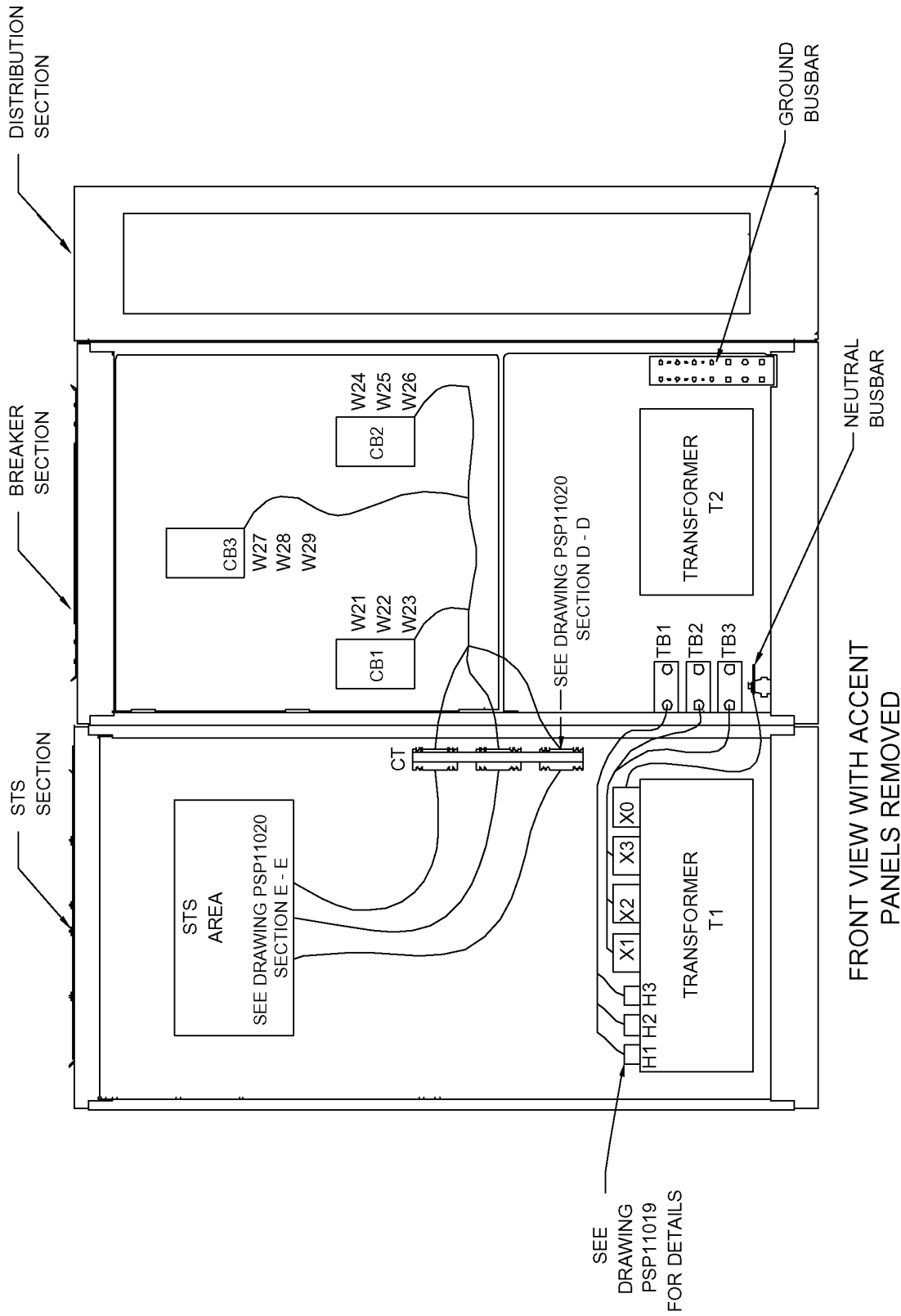

NOTES:

1. INTERCONNECTION WIRING FROM T1 TO TB1, 2, 3, & NEUTRAL BUSBARS ARE ATTACHED TO T1 AND SHIPPED IN THE STS SECTION. SEE DRAWING PSP11019 FOR DETAILS.
2. INTERCONNECTION WIRING FROM CB1, CB2, & CB3 TO STS SECTION ARE ATTACHED TO CB1, CB2, & CB3 AND SHIPPED IN THE BREAKER SECTION. SEE DWG PSP11020 FOR DETAILS.

PSP11026
Rev. 0

Figure 44 Electrical field connections, 800A Liebert STS2/PDU interconnect wiring, right side one-line with CB3A

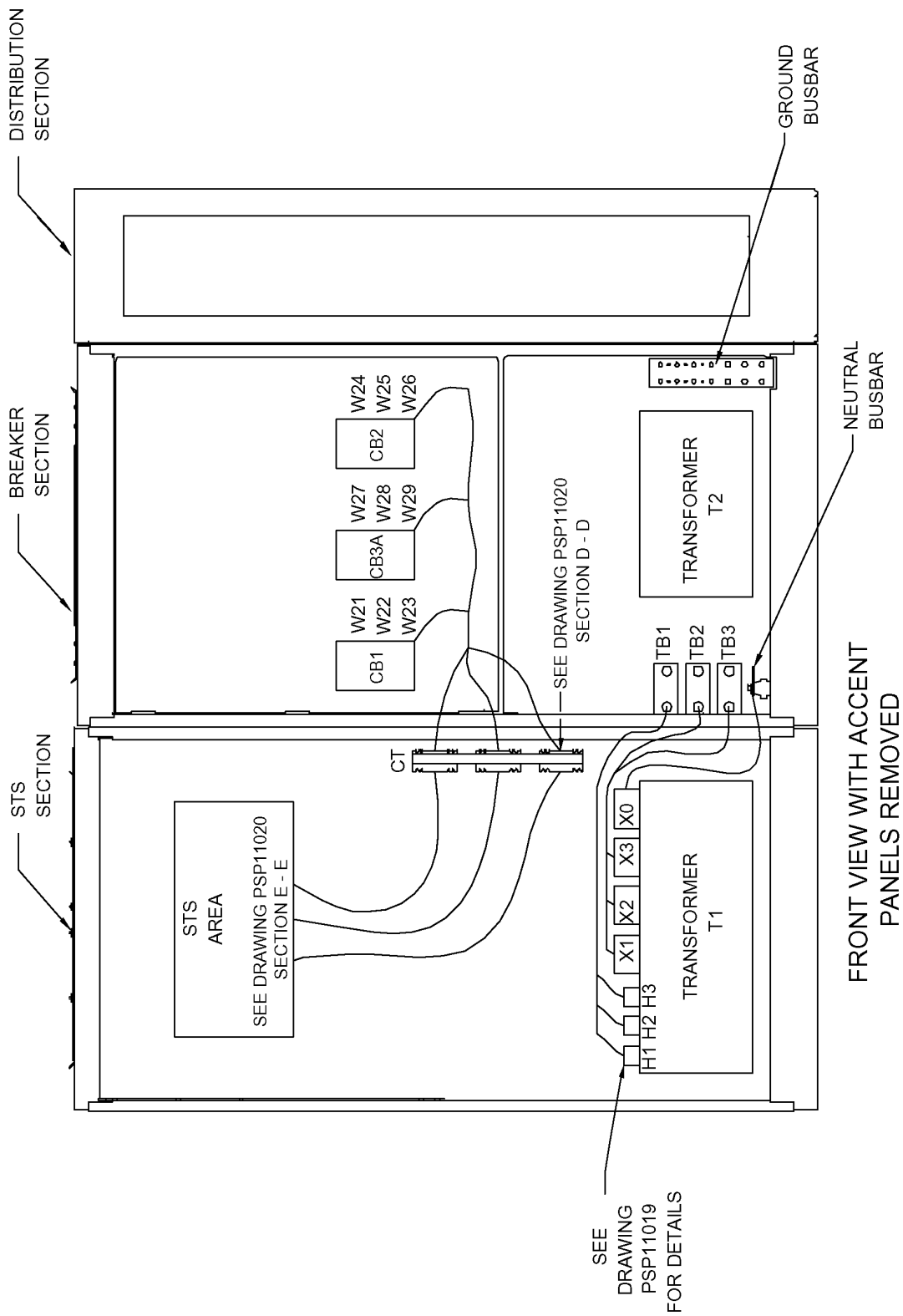

NOTES:

1. INTERCONNECTION WIRING FROM T1 TO TB1, 2, 3, & NEUTRAL BUSBARS ARE ATTACHED TO T1 AND SHIPPED IN THE STS SECTION. SEE DRAWING PSP11019 FOR DETAILS.
2. INTERCONNECTION WIRING FROM CB1, CB2, & CB3A TO STS SECTION ARE ATTACHED TO CB1, CB2, & CB3A AND SHIPPED IN THE BREAKER SECTION. SEE DWG PSP11020 FOR DETAILS.

PSP11027
Rev. 0

Figure 45 Control wiring, 800A Liebert STS2/PDU, left side distribution

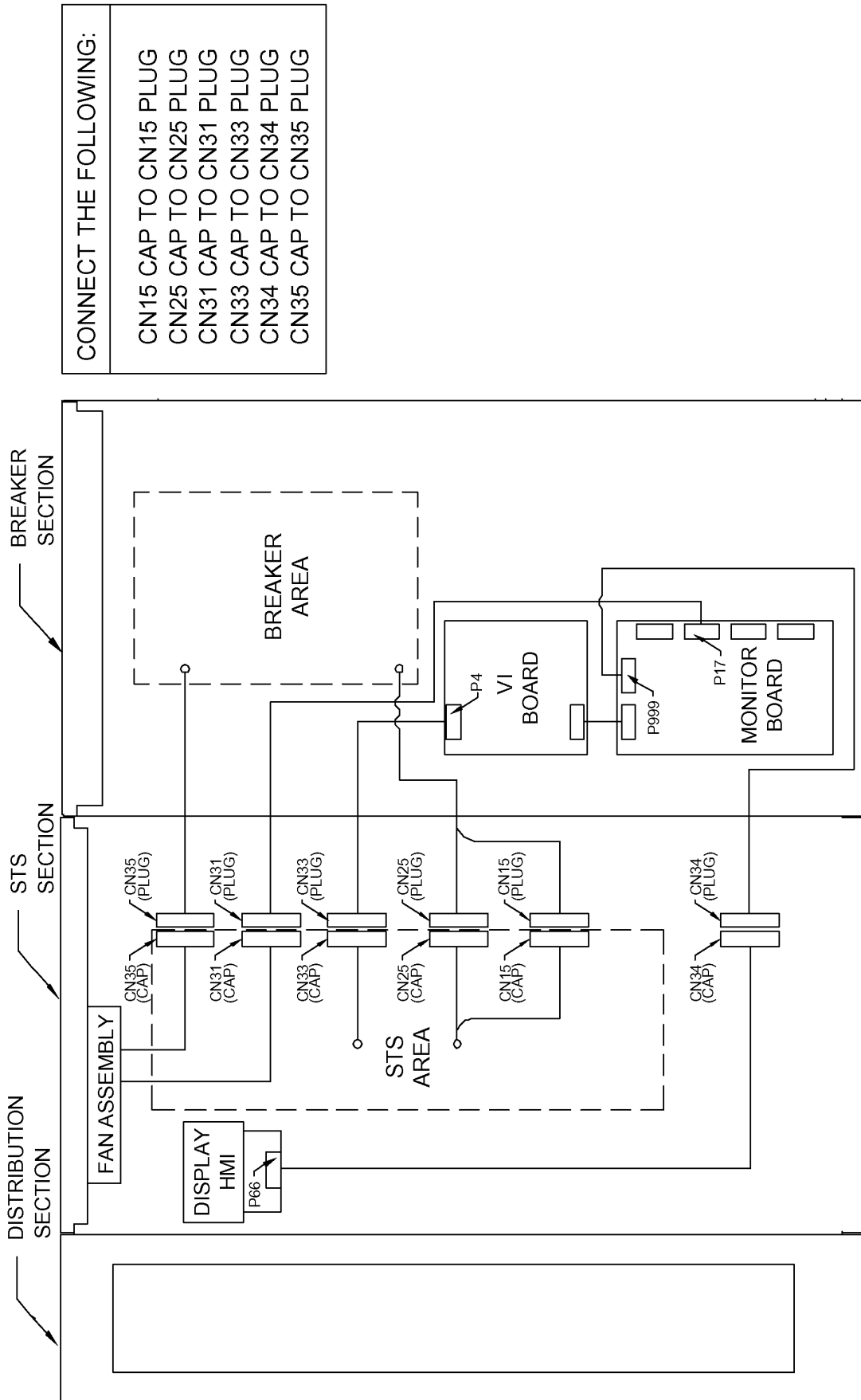

CONNECT THE FOLLOWING:

- CN15 CAP TO CN15 PLUG
- CN25 CAP TO CN25 PLUG
- CN31 CAP TO CN31 PLUG
- CN33 CAP TO CN33 PLUG
- CN34 CAP TO CN34 PLUG
- CN35 CAP TO CN35 PLUG

FRONT VIEW WITH ACCENT
PANELS REMOVED

PSP13801
Rev. 0

Figure 46 Control wiring, 800A Liebert STS2/PDU, right side distribution

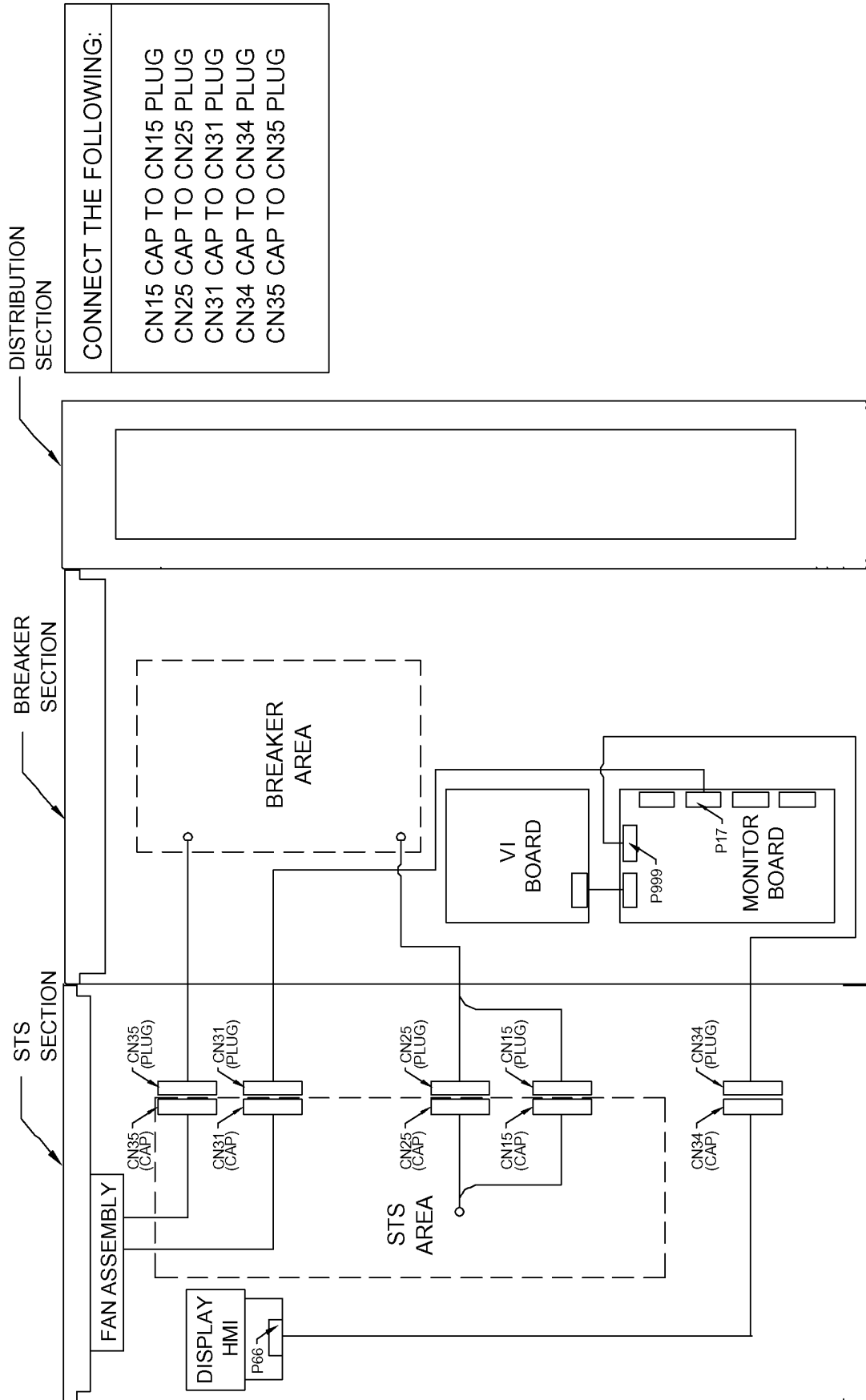

FRONT VIEW WITH ACCENT
PANELS REMOVED

PSP13802
Rev. 0

Figure 47 Control connection location, 250A Liebert STS2/PDU

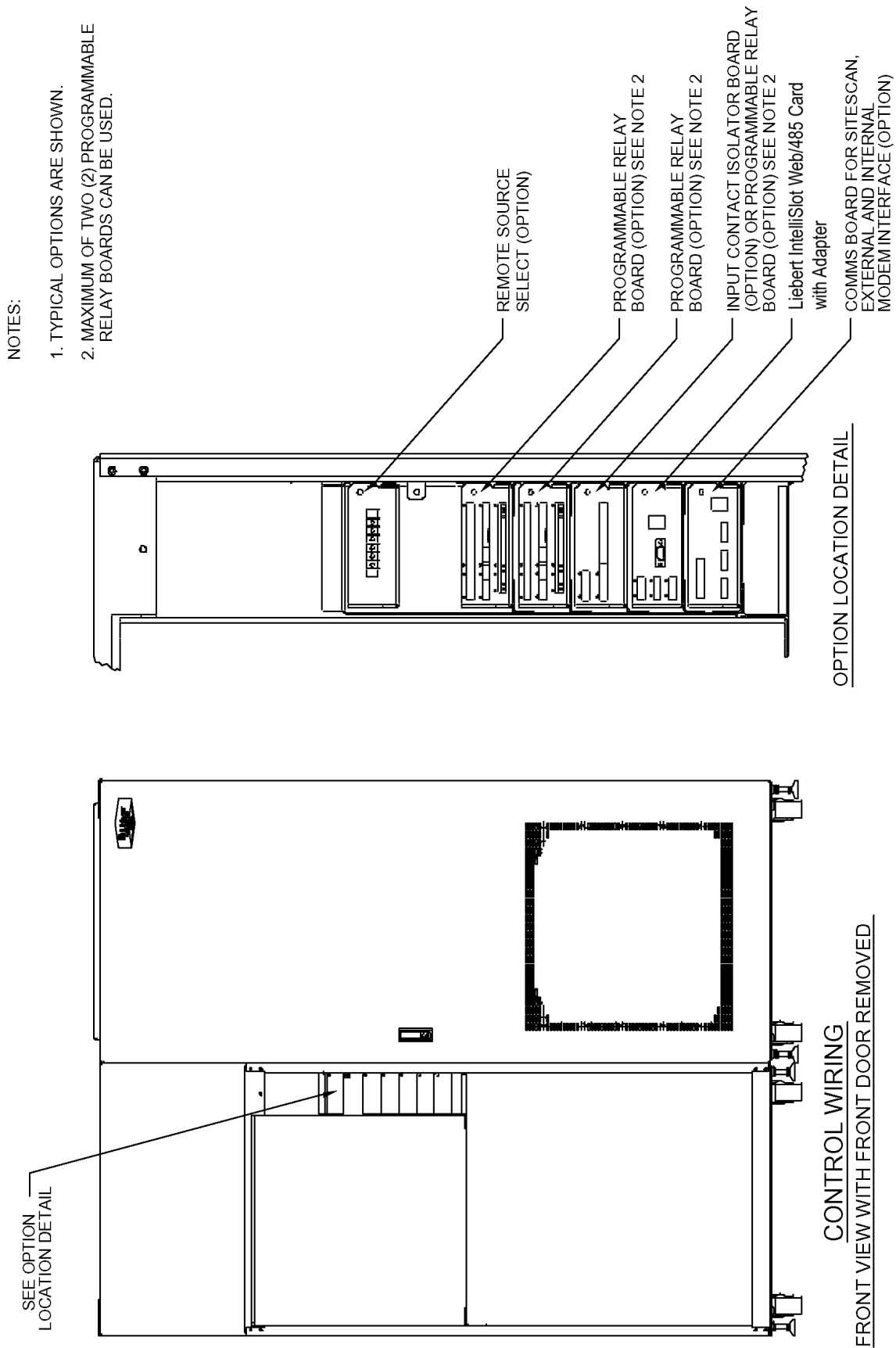

PSP13200
Rev. 03

Figure 48 Control connection location, 400-800A Liebert STS2/PDU

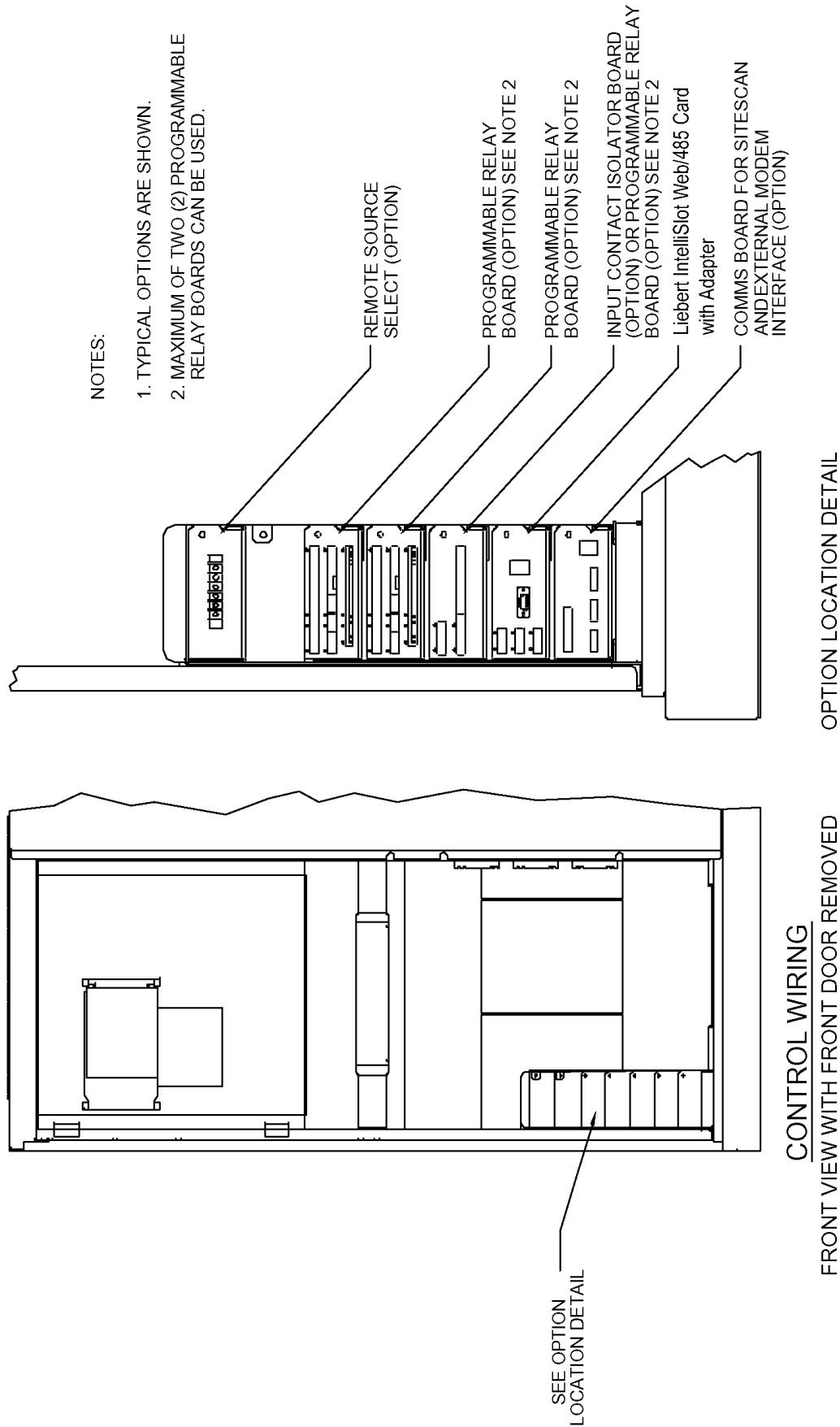

PSP13800
Rev. 03

Figure 49 Control location drawing conduit box, top entry, 400-600A Liebert STS2/PDU

- NOTES:
1. THE CONTROL CONDUIT BOX IS MOUNTED UPSIDE DOWN AND INSIDE OF TOP OF THE UNIT FOR SHIPPING.
 2. REMOVE THE BOX AND SIDE COVER.
 3. DRILL TOP OF BOX FOR CONDUITS.
 4. REPLACE THE BOX AS SHOWN IN THE INSTALLED VIEW.
 5. INSTALL CONDUIT AND LAND CABLES.
 6. REPLACE SIDE COVER.

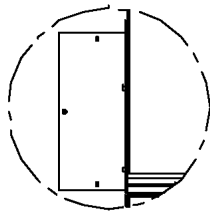

DETAIL A

REMOVE SIDE COVER TO INSTALL CONDUIT AND CABLES. THEN REPLACE SIDE COVER.

CONTROL CONDUIT BOX
SEE DETAIL A AND NOTES.

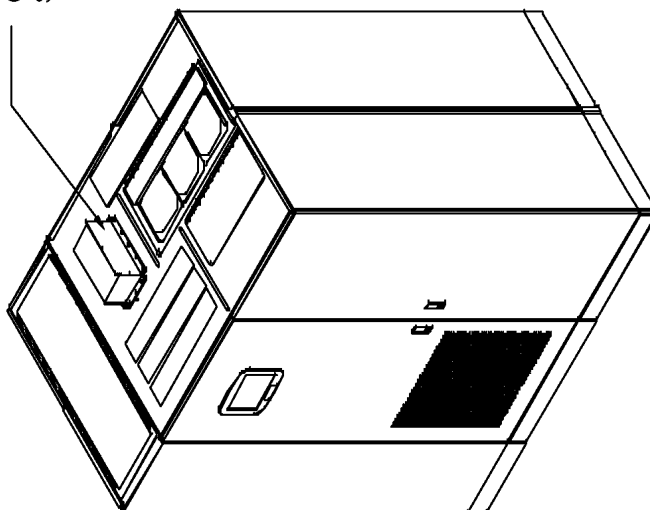

UNIT WITH CONDUIT BOX INSTALLED

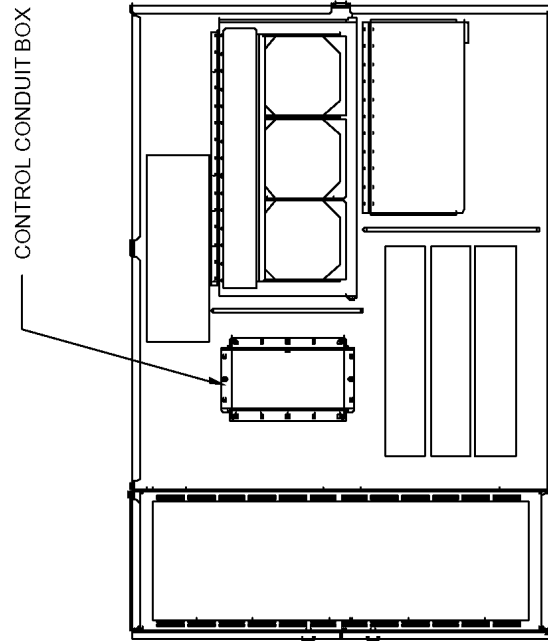

TOP VIEW

PSP13401
Rev. 01

Figure 50 Control wiring for the programmable relay board option

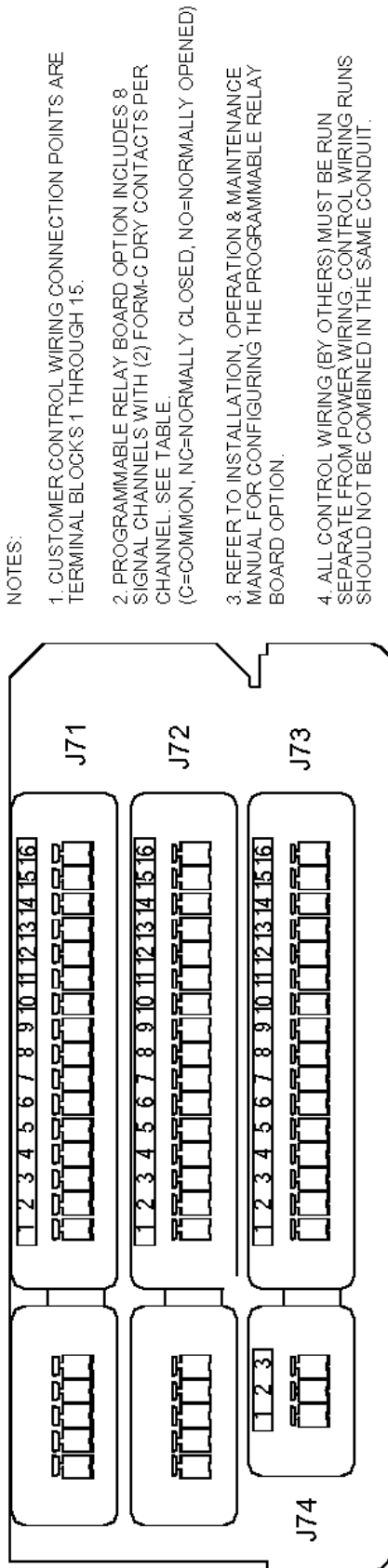

NOTES:

1. CUSTOMER CONTROL WIRING CONNECTION POINTS ARE TERMINAL BLOCKS 1 THROUGH 15.
2. PROGRAMMABLE RELAY BOARD OPTION INCLUDES 8 SIGNAL CHANNELS WITH (2) FORM-C DRY CONTACTS PER CHANNEL. SEE TABLE (C=COMMON, NC=NORMALLY CLOSED, NO=NORMALLY OPENED)
3. REFER TO INSTALLATION, OPERATION & MAINTENANCE MANUAL FOR CONFIGURING THE PROGRAMMABLE RELAY BOARD OPTION.
4. ALL CONTROL WIRING (BY OTHERS) MUST BE RUN SEPARATE FROM POWER WIRING. CONTROL WIRING RUNS SHOULD NOT BE COMBINED IN THE SAME CONDUIT.
5. REFER TO STATIC TRANSFER SWITCH CONTROL CONNECTION DIAGRAM FOR LOCATION OF PROGRAM RELAY BOARD OPTION.
6. CONTACT RATINGS: 1AMP @ 30VDC, 200mA @125VAC.
7. MAXIMUM CABLE LENGTH 500 FT. (152 METERS) WITH #16AWG FLEXIBLE STRANDED CABLE.
8. ALL WIRING MUST BE IN ACCORDANCE WITH NATIONAL AND LOCAL ELECTRICAL CODES.

PROGRAMMABLE RELAY BOARD

TABLE

	CHANNEL	PIN NO.	C	NC	NO
J71	CH1	A 1-3	1	2	3
	B	4-6	4	5	6
J72	CH2	A 7-9	7	8	9
	B	10-12	10	11	12
J73	CH3	A 13-15	13	14	15
	B	1-3	1	2	3
J74	CH4	A 4-6	4	5	6
	B	7-9	7	8	9
J75	CH5	A 10-12	10	11	12
	B	13-15	13	14	15
J76	CH6	A 1-3	1	2	3
	B	4-6	4	5	6
J77	CH7	A 7-9	7	8	9
	B	10-12	10	11	12
J78	CH8	A 13-15	13	14	15
	B	1-3	1	2	3

NOTE: PIN 16 NOT USED ON J71, J72, & J73

Figure 51 Control wiring for the input contact isolator board option

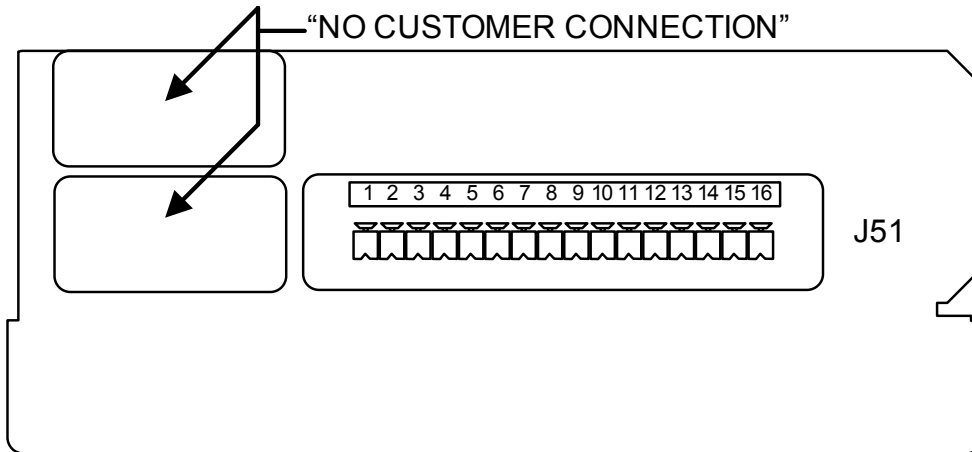

INPUT CONTACT ISOLATOR BOARD
02-810012-XX

PS213002
Rev. 02

Table J51

Input Contact	Pin No.
1	1
	2
2	3
	4
3	5
	6
4	7
	8
5	9
	10
6	11
	12
7	13
	14
8	15
	16

NOTES:

1. Customer control wiring connection points are Terminals 1 through 16 (see Table J51).
2. Customer-provided, normally open, dry contacts for user alarm messages.
3. Refer to installation, operation AND maintenance manual for configuring the input contact isolator board option.
4. All control wiring (by others) must be run separate from power wiring. Control wiring runs should not be combined in the same conduit.
5. Refer to static transfer switch control connection diagram for location of input contact isolator board option.
6. Signal voltage: 100mA @ 12VDC.
7. Maximum cable length 500 ft. (152 meters) with #16 AWG flexible, stranded cable.
8. All wiring must be in accordance with national and local electrical codes.

Figure 52 Control wiring for comms board

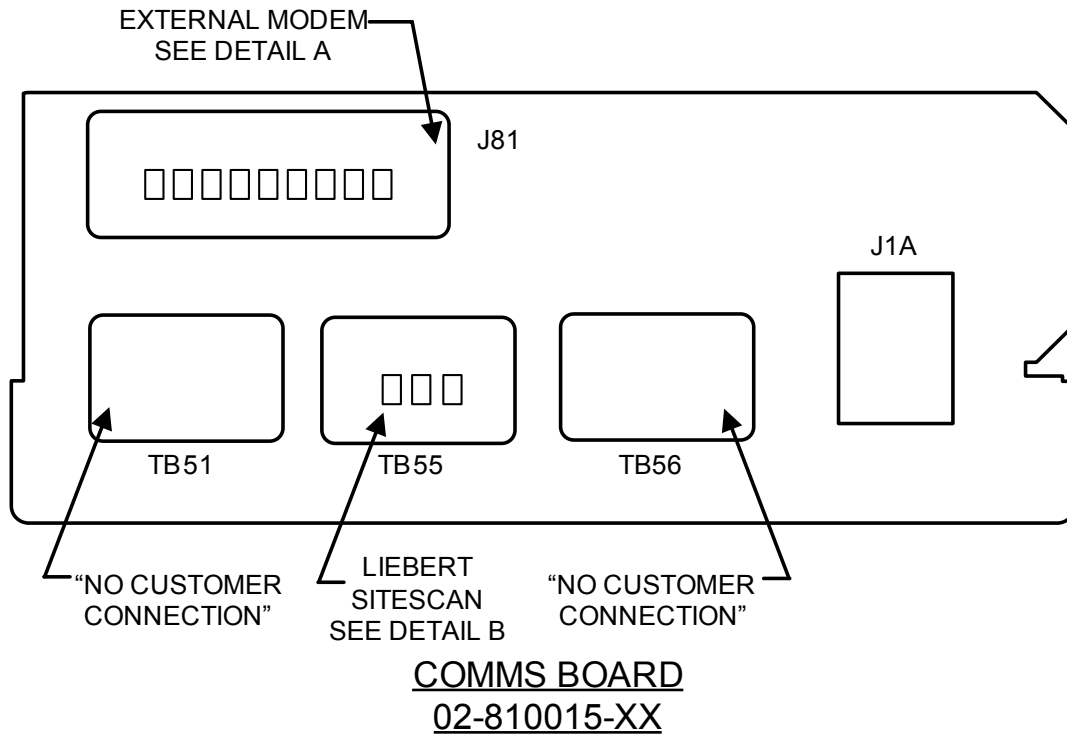

CUSTOMER-SUPPLIED
INTERCONNECTING CABLE
TO EXTERNAL MODEM

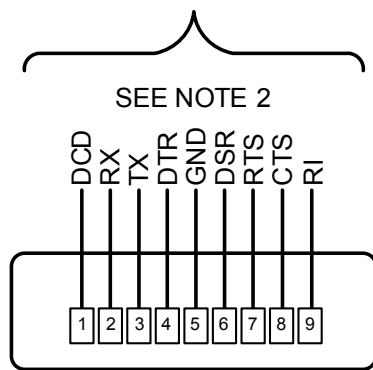

J81
DETAIL A

CUSTOMER-SUPPLIED
INTERCONNECTING CABLE
TO LIEBERT SITESCAN

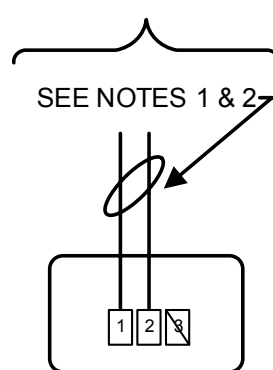

TB 55
DETAIL B

PS213003
Rev. 02

NOTES

1. Maximum cable length 1000 feet (300 meters) with twisted pair cable #22 AWG 300V minimum.
2. Signal voltage 5VDC, current 10mA.
3. Refer to installation, operation and maintenance manual for configuring the COMMS board.
4. All control wiring (by others) must be run separate from power wiring. Control wiring runs should not be combined in the same conduit.
5. Refer to control connection location diagram of static transfer switch for location of COMMS board.
6. All wiring must be in accordance with national and local electrical codes.

Figure 53 Control wiring for the Liebert IntelliSlot Web/485 Card With Adapter option

- Notes:
1. Wire size and type: 10/100 base-T ethernet cable with RJ-45 plug connector. The length is limited by internet standards.
 2. Maximum cable length 1000 feet (300 meters) with twisted pair cable #22 AWG minimum. Signal voltage 5VDC, current 10mA.
 3. Refer to the Liebert IntelliSlot Web/485 Card's installation, operation & maintenance manual for configuration details.
 4. All control wiring (by others) must be run separate from power wiring. Control wiring runs should not be combined in the same conduit.
 5. Refer to control connection location diagram of static transfer switch for location of Liebert IntelliSlot Web/485 card option.
 6. All wiring must be in accordance with national and local electrical codes.

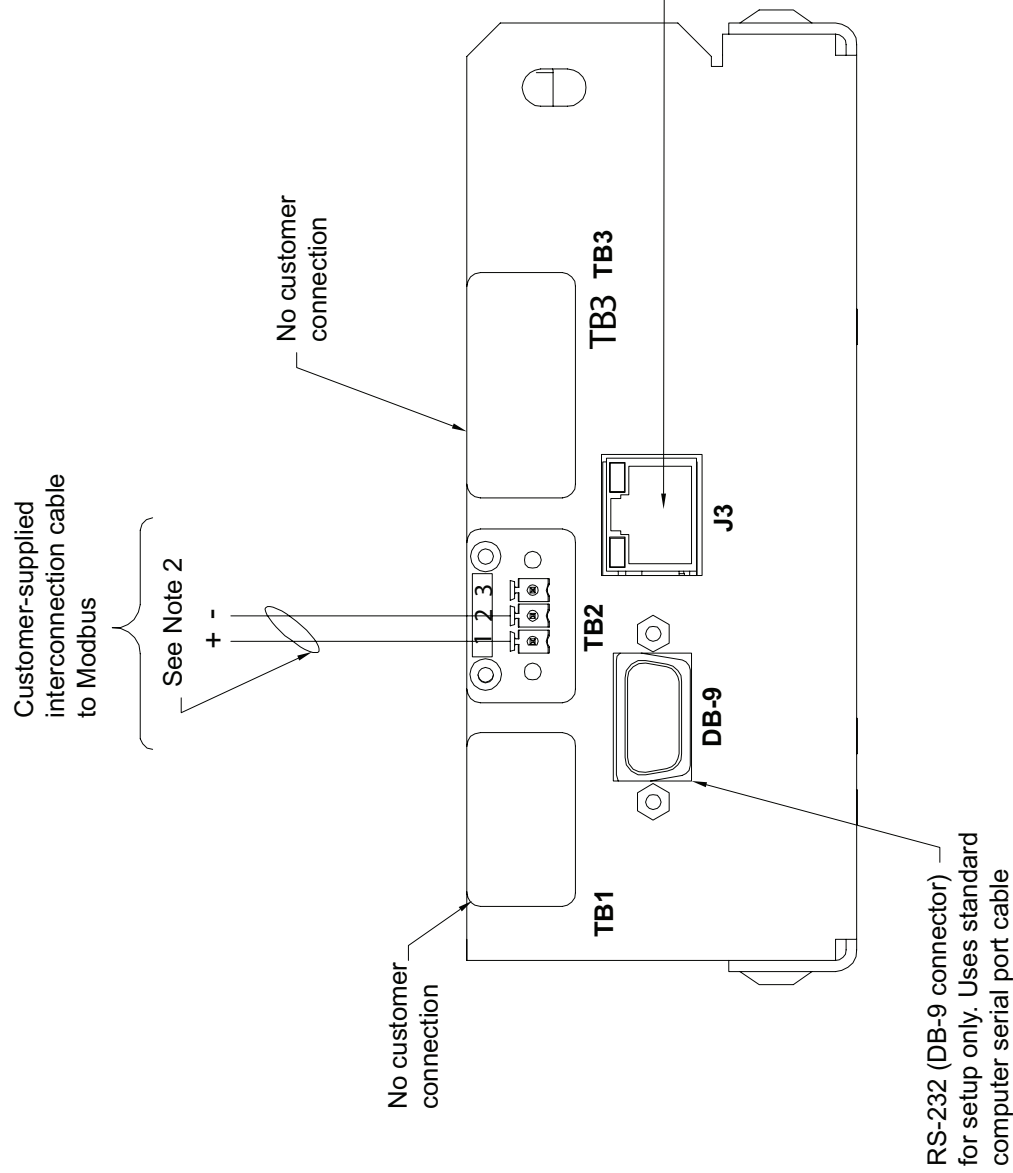

PS213008
Rev. 01

Figure 54 Control wiring for the RS-232 Port

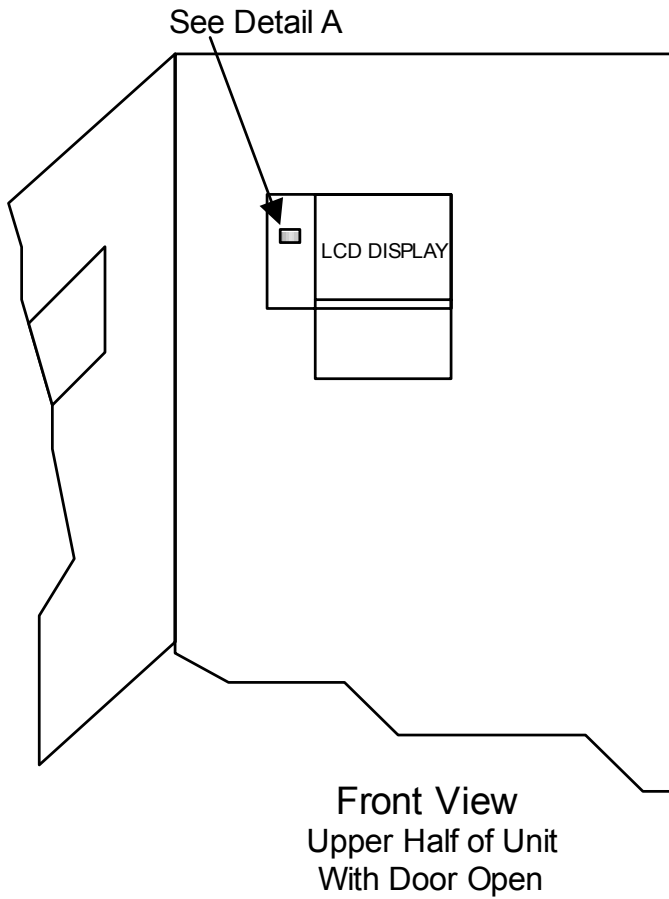

NOTES

1. RS-232 communication through DB9 connector .
2. Connector accessible with front door open . Connector must be removed before closing door .

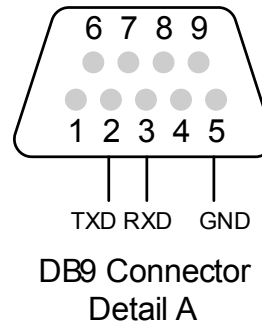

PS213006
Rev. 01

Figure 55 Control wiring for remote source selection option

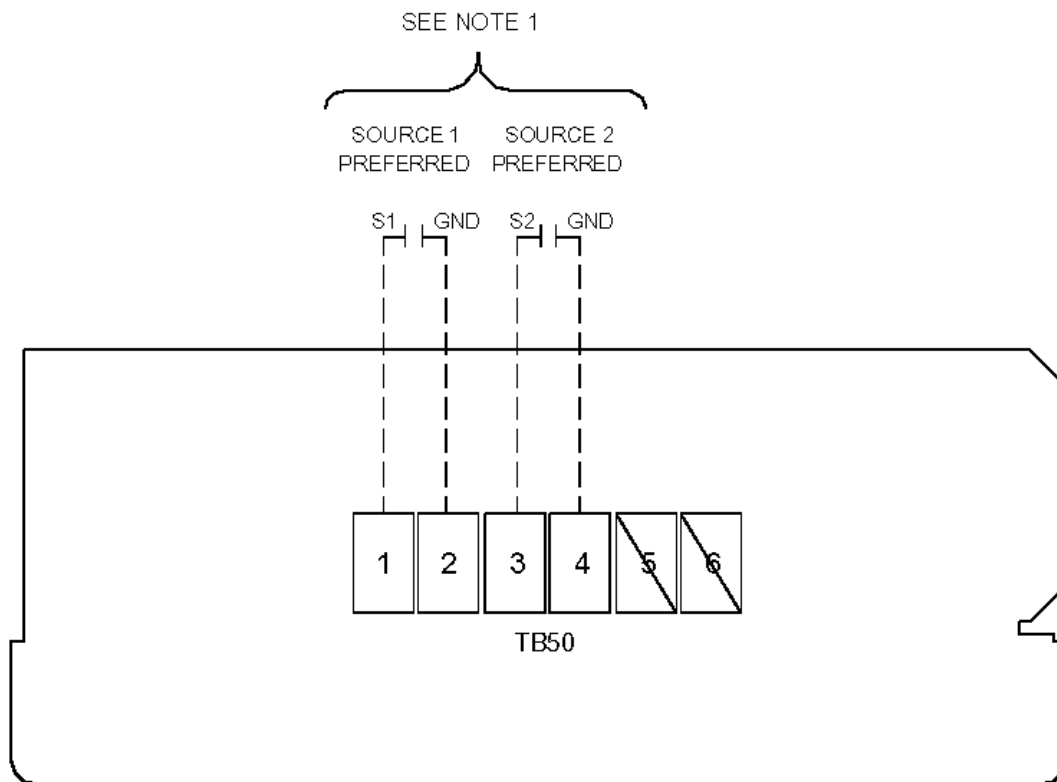

REMOTE SOURCE SELECTION

NOTES:

1. CUSTOMER PROVIDED NORMALLY OPEN DRY CONTACTS. RATING 10mA AT 30VDC.
2. MAXIMUM CABLE LENGTH 500 FT. (152 METERS) WITH #16AWG 300V MINIMUM, FLEXIBLE STRANDED CABLE.
3. ALL CONTROL WIRING (BY OTHERS) MUST BE RUN SEPARATE FROM POWER WIRING. CONTROL WIRING RUNS SHOULD NOT BE COMBINED IN THE SAME CONDUIT.
4. REFER TO STATIC TRANSFER SWITCH CONTROL CONNECTION DIAGRAM FOR LOCATION OF REMOTE SOURCE SELECTION OPT.
5. ALL WIRING MUST BE IN ACCORDANCE WITH NATIONAL AND LOCAL ELECTRICAL CODES.

PS213007
Rev. 02

Figure 56 Color LCD touch screen display

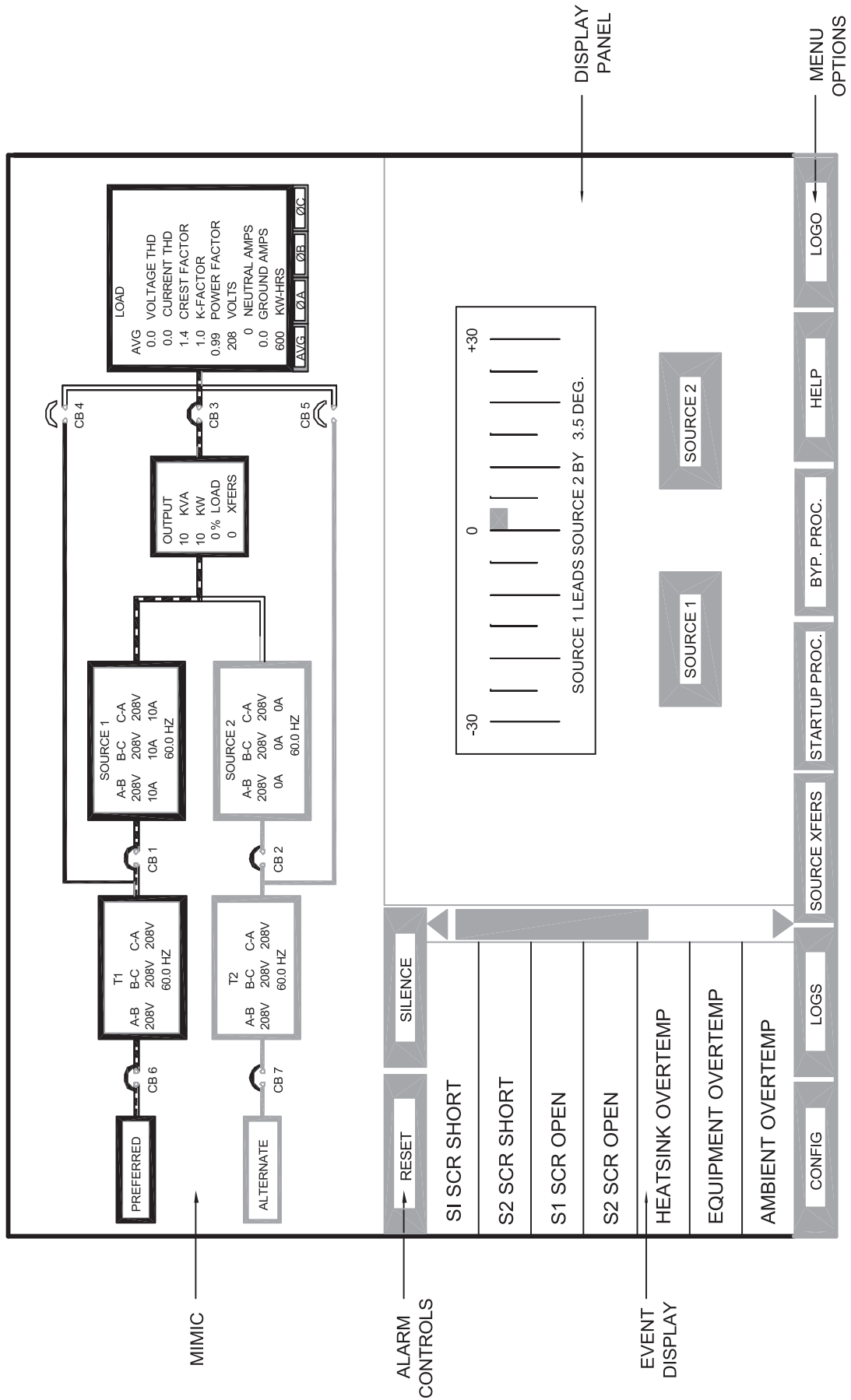

PSP11900
Rev. 01

Table 8 Input circuit breaker schedule, 250-800A

Liebert STS2/PDU Rating	Liebert STS2/PDU Input Volts	Circuit Breakers (See One-Line Diagrams)	Vendor	Type	Ampacity	Voltage	Interrupting Rating (Amps)
250A	208V	CB6 & CB7	MERLIN GERIN	NJHN	400A	208-240V	100K
	480V			NFNN	150A	380-480V	35K
	600V			NFNN	125A	600V	18K
400A	480V	CB6 & CB7	MERLIN GERIN	NJHN	250A	380-480V	65K
	600V			NJHN	200A	600V	25K
600A	480V	CB6 & CB7	MERLIN GERIN	NJHN	400A	380-480V	65K
	600V			NJHN	300A	600V	25K
800A	480V	CB6 & CB7	MERLIN GERIN	NJHN	500A	380-480V	65K
	600V			NJHN	400A	600V	25K

Table 9 Output circuit breaker schedule, 250-800A

Liebert STS2/PDU Rating	Liebert STS2/PDU Input Volts	Circuit Breakers (See One-Line Diagrams)	Vendor	Type	Ampacity	Voltage	Interrupting Rating (Amps)
250A	208V	CB8	MERLIN GERIN	NJHN	250A	208-240V	100K
400A	208V	CB8	MERLIN GERIN	NJHN	400A	208-240V	100K
600A	208V	CB8	Square D	PGD	600A	208-240V	65K
800A	208V	CB8	Square D	PGD	800A	208-240V	65K

Table 10 Non-automatic breaker schedule, 250-800A

Liebert STS2/PDU Rating	Circuit Breakers (See One-Line Diagrams)	Vendor	Type	Ampacity	Voltage	Withstand Current
250A	CB1, CB2, CB3 CB3A, CB4, CB5	Square D	JLN	250A	208-240V	125K
					380-480V	100K
400A	CB1, CB2, CB3 CB3A, CB4, CB5	MERLIN GERIN	NSJ	400A	208-240V	100K
					380-480V	100K
600A	CB1, CB2, CB3 CB3A, CB4, CB5	MERLIN GERIN	NSJ	600A	208-240V	100K
800A	CB1, CB2, CB3 CB3A, CB4, CB5	Square D	PJD	1000A	208-240V	100K

8.0 INTRODUCTION TO LIEBERT STS2/PDU OPERATION

8.1 System Description

A Liebert STS2/PDU provides an automatic, seamless transfer between input power sources to an output load. The Liebert STS2/PDU monitors the input sources, to ensure each source is operating within set parameters, as well as ensure that each source is within acceptable tolerances for a transfer between sources to be completed.

The Liebert STS2/PDU contains two static transfer switches in one enclosure to allow the unit to transfer its load between the two input sources without disruption to the output for longer than 1/4 of a cycle.

If a problem is detected with a primary (Preferred) input source and defined trigger points are reached, the Liebert STS2/PDU automatically switches the input to the other (Alternate) input source. The Liebert STS2/PDU continues to monitor both sources and can automatically transfer the load back to the preferred source, if so configured, when that source returns to acceptable operating parameters.

The system control logic automatically monitors the input sources and power output to ensure that they are operating within acceptable tolerances. The system logic manages the transfer between sources.

The Liebert STS2/PDU front panel contains a Color Graphical Display on an LCD touch screen display. The Color Graphical Display provides a menu-driven operator interface and a display of system information, status information, a one-line diagram (Mimic) of the Liebert STS2/PDU, active alarms and alarm history information.

The menu selections provide control of the preferred source, manual transfer initiation. Buttons provide for audible alarm silence and reset.

Through the touch screen, specific voltage, current and environmental parameters can be configured to trigger events that can sound an alarm, write to a history log and either transfer sources or inhibit a transfer.

Preferred input source selection, alarm reset and alarm silencing are done through buttons on the touch screen display.

Communication options provide external communication with the Liebert STS2/PDU through a modem, a network card, a programmable relay board, a contact isolator or an RS-422 port to Liebert's SiteScan.

8.1.1 Redundancy

Redundancy within the Liebert STS2/PDU prevents one component from being a single point of failure, should a problem occur. Redundant circuits and components are used to eliminate single points of failure.

Since the Liebert STS2/PDU has two input sources, no single component failure can cause a loss of power to the load. Redundant power supplies are provided which feed a DC dual-bus used throughout the unit to prevent any single-point power supply failure modes.

Three separate redundant control logic modules are built into the system. Each contains the logic necessary to run the Liebert STS2/PDU and control all transfers.

Redundant fans are provided if a primary fan fails. The redundant fans turn on to prevent overheating inside of the unit.

Should the front panel interface fail, the control logic continues to operate and the unit would transfer should a problem be detected on the preferred source. Information on the monitoring parameters would be available through the remote communication options, if available, or the DB9 (RS-232) connector located next to the LCD behind the front door. See **Figure 54** for details.

8.1.2 Reliability and Agency Requirements

The Liebert STS2/PDU is designed for high reliability and high availability with a critical bus Mean Time Between Failure (MTBF) exceeding 1,000,000 hours.

The Liebert STS2/PDU and all its options are designed, tested and certified, where applicable, to meet agency requirements as follows:

- UL 891: Standard for Switchboard, for UL and ULc listing
- UL 1008: Standard for Automatic Transfer Switches
- UL 67: Standard for Panelboard
- UL 1561: Standard for Dry Transformers
- UL 1459: Telephone equipment (Modem)
- NEC
- FCC Part 15 EMI emission limits for Class A computing devices.

The Liebert STS2/PDU uses conservatively rated components, minimizing the need to go to maintenance bypass. All normal maintenance and repair work can be done through the front panel of the unit. This access makes repairs and maintenance easier.

Gating and control logic are partitioned so that failure of one source's gating or sensing logic does not prevent the switch from transferring to the other source.

All control and logic components are mounted separate from the power components. The Liebert STS2/PDU is designed to minimize the exposure of hazardous voltages to allow safe servicing of the unit while the load is energized.

All electrical components requiring normal maintenance are replaceable without de-energizing the load, as long as one source is available. Solid-state switching devices are packaged to allow safe repair of those devices without having to de-energize the load. All non-automatic switches or circuit breakers are the plug-in or draw-out type to allow replacement without de-energizing the load. All other components, including transformers, power cables and connections, circuit breaker bases, etc., are replaceable from the front, rear or top of the unit—however, this requires all power to be removed from the unit for safety. All solid-state power switching devices are rated to prevent hazardous device failure in power systems with available fault currents up to the defined limits, as listed in **14.1.6 - Electrical Requirements**.

8.1.3 Factory Backup and Service Assistance

Because improper installation can cause a system to fail, a Liebert Services or a factory-trained service technician should thoroughly inspect the unit to ensure it is properly installed and its operating parameters are properly configured.

Once the Liebert STS2/PDU is properly installed, you, as the on-site operator, can easily monitor the unit's operation utilizing the touch screen.

In the United States, if you need assistance or have questions, call 1-800-LIEBERT (1-800-543-2378).

Outside the 48 contiguous United States, contact Liebert Services, if available in your area.

For international areas not covered by Liebert Services, the Liebert authorized distributor can provide technical support.

8.2 Modes of Operation

8.2.1 Normal (Preferred Source)

Under normal operating conditions, the Liebert STS2/PDU routes power from the preferred input source to the output load. The unit monitors the voltage current and phase of each source to ensure that both are operating within set tolerances and that the alternate source is available, should a transfer be required.

8.2.2 Transfer

Should the preferred source fail or be outside acceptable voltage limits, the Liebert STS2/PDU transfers the input to the alternate source until the problem is rectified in the preferred source. The unit can be set to automatically transfer the input back to the preferred source or allow the transfer to be done only manually.

8.2.3 Transfer Inhibit

For a transfer to be completed between input sources, the sources must meet certain parameters or the transfer cannot take place. Uninterrupted transfer between sources is inhibited due to input source failure, sources out of sync, switch failure or the unit is in bypass mode.

8.2.4 Bypass

The Liebert STS2/PDU can be manually bypassed to allow the power from a source to directly flow to the output load. This bypass allows the unit's electronics to be serviced without dangerous voltages being present.

The Liebert STS2/PDU includes key-interlocked maintenance bypass breakers that allow either input source's electronics to be bypassed for maintenance without interruption of power to the load. The maintenance bypass allows all electronics to be isolated from the input, output and bypass connections. Bypass instructions are available from the touch screen and are discussed later in this manual.

8.3 Operator Controls

The Liebert STS2/PDU is equipped with an interface to configure and monitor the unit either locally or remotely. The Color Graphical Display is a touch screen LCD that provides a color diagram (Mimic) that displays the current status of the unit. System parameters are displayed and help is available to define events. See **Figure 57** below and **Figure 56** in **7.0 - Installation Drawings**. The touch screen menus allow the operator to initiate source transfers, view event and history logs and view bypass and other operational instructions.

Figure 57 Liebert STS2/PDU touch screen display

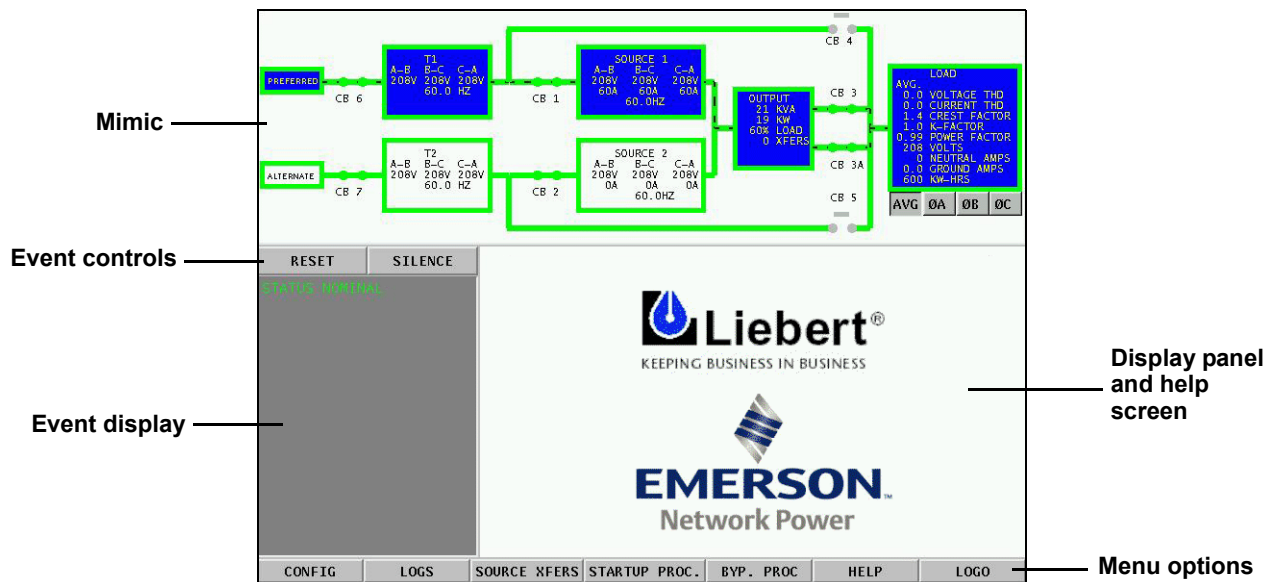

Touch screen control buttons allow you to reset alarms, silence the audible alarm, review configurations, event and history logs, preferred source, startup and bypass procedures and the help menu.

Qualified personnel, with a password, can use these menus to configure parameters, select a preferred source and do manual source transfers.

Units can be accessed from a terminal or a PC running terminal emulation software attached to the unit. Through the RS-232 access, you can monitor and configure the unit, plus remotely select a preferred source. See **12.1 - Using the RS-232 Port** for instructions on using the RS-232 interface.

9.0 THEORY OF OPERATION

9.1 General Description

The Liebert STS2/PDU contains all the equipment necessary to prevent an interruption in power flow to the AC load, should your primary source fail.

9.1.1 Liebert Static Transfer Switch 2/Power Distribution Unit

The Liebert STS2/PDU is a combination automatic static transfer switch and power distribution unit. The Liebert STS2/PDU shall include two isolation transformers connected to a solid-state, three-pole, dual-position static transfer switch designed to automatically and manually switch between two synchronized three-phase AC power sources without an interruption of power to the load longer than 4 milliseconds (1/4 cycle). Input, output, bypass circuit breakers and a distribution section shall be included to form an integrated system in a single freestanding enclosure.

The preferred source is the input source that normally carries the load when both sources are available. The preferred source is selectable by the user from the LCD panel or an optional Remote Source Selection. The unselected source is referred to as the alternate source and carries the load if the preferred source should fail or if a manual transfer is initiated.

The unit uses Silicon Controlled Rectifiers (SCRs) connected in paralleled, opposing pairs to function as an AC switch configuration. Three pairs of SCRs connect the AC load to the selected preferred input source as long as the preferred source is available. A second set of SCRs stands ready to transfer the AC load to the alternate input source should the preferred source fail. The switching action is a very fast, break-before-make with less than a 1/4 cycle break in the AC waveform.

During static switch transfers and retransfers, the conduction state of the SCRs is carefully monitored and controlled to prevent a current path from one source to the other. This technique prevents a faulted source from feeding into the other good source.

9.1.2 Source Transfer

The Liebert STS2/PDU allows manually initiated transfers between the two sources, providing the alternate source is within acceptable voltage limits and phase tolerances with the preferred source. You begin a manual transfer by selecting the inactive source as the preferred source. On a manual transfer, the Liebert STS2/PDU transfers between the two sources with less than one (1) millisecond interruption of power to the load. The transfer can only be completed when both sources are available and synchronized within the user-adjustable phase synchronization window. For sources where the two frequencies are not exactly in phase, manually-initiated transfers are delayed by the Liebert STS2/PDU until the two sources are within the defined phase synchronization window.

Source selection can also be done remotely using the Remote Source Selection option, if installed.

9.1.3 Automatic Transfer/Retransfer

If the preferred source is out of voltage and/or frequency limits, the load is automatically transferred to the alternate source. The default transfer voltage limits comply with the limits of the IEEE Std. 446-1995 computer voltage tolerance envelope.

If the unit is so configured, the load is retransferred automatically to the preferred source after the preferred source returns to within the acceptable voltage and frequency limits for at least the defined retransfer time delay and is in phase with the alternate source. You can enable and disable automatic retransfer to the preferred source through a user configuration setting.

Automatic Retransfer Inhibited

If the system makes five transfers from the preferred source to the alternate source in a five minute period, automatic retransfers back to the preferred source is disabled.

To clear this alarm condition, you must assign the alternate source as the preferred source. Also, the UV detection thresholds may need adjustment. See **Source Setpoints on page 100** for instructions on setting the UV detection.

This alarm also is cleared if the unit transfers to the preferred source due to an alternate source AC volt failure (i.e., an emergency transfer.)

9.1.4 Emergency Transfer

To ensure that power remains connected to the load, the Liebert STS2/PDU automatically performs an emergency transfer from one input source to the other when an outage occurs on the existing source.

The automatic transfer takes place if the other source's voltage is within acceptable limits and regardless of the phase difference between the two sources.

Emergency transfers occur with a loss of power on the output of less than 4 ms.

Emergency transfers from the alternate source to the preferred source are not affected by the Auto Retransfer Enabled/Disabled or Retransfer Delay user settings.

9.1.5 Load Current Transfer Inhibit

The Liebert STS2/PDU senses the load current. If the load current exceeds the preset level deemed to represent a load inrush or fault condition, the unit's logic disables manual and automatic transfers, even if the selected source's input voltage is outside the acceptable limits. This event triggers an I-Peak alarm. If so configured, the Load Current Transfer Inhibit is automatically reset after the current and voltage return to within normal parameters. This reset provides continued protection against a source failure. The Load Current Transfer Inhibit also can be programmed to require a manual reset. See **Step 14** in **Source Setpoints on page 100** for details.

9.1.6 SCR Failure

The Liebert STS2/PDU continuously monitors the status of the SCR switching devices for proper operation. In the event of a shorted SCR on the input source powering the load, the Liebert STS2/PDU automatically triggers an alarm and trips open the other source isolation breaker. In the event of a shorted SCR on the other input source, the Liebert STS2/PDU automatically triggers an alarm and trips open the other source isolation breaker.

In the event of an open SCR, the switch automatically triggers an alarm and transfers the load to the other source. All open and shorted SCR alarm conditions are latched and require the system to be repaired and reset to restore normal operation.

9.1.7 On/Off Sequence

The Liebert STS2/PDU contains no master On/Off push button control. When connected to the input sources, the unit's logic power comes on automatically. The touch screen display is active as long as at least one input source is energized and the Control Power Disconnect (located inside the static switch) is closed.

9.2 Detailed Component Description

9.2.1 Controls

Operator Interface

The Liebert STS2/PDU Color Graphical Display unit contains a touch screen color LCD to provide the operator interface to control and configure the operation of the unit and quickly diagnose problems. A password and an optional keylock, if installed, are provided for security.

Hardware

- The Liebert STS2/PDU operator interface in the Color Graphical Display unit is designed to provide all of the information required to configure and monitor the unit's operation.
- The control logic performs automatic operations with minimal operator interface.
- Each Liebert STS2/PDU unit is equipped with a color LCD touch screen.
- The Liebert STS2/PDU can have optional communication ports installed. See **6.0 - Options** and **12.0 - Communication Interfaces** for more information on communication options.
- The RS-232 interface is used for configuration and status and event log monitoring.

Firmware

The operator interface enables you to monitor the Liebert STS2/PDU, to configure setpoints for transfers, monitor system parameters and access event and history logs. The firmware is accessible through the LCD touch screen or the RS-232 interface. The firmware includes:

- View and set the preferred source.
- View and configure setpoints.
- View alarms, faults and status.
- The mimic graphical representation of the systems operation.
- Menu driven monitoring and configuration.
- Step-by-step instructions to assist you in the startup, shutdown and bypass operations.
- Help on event messages.
- Touch screen alarm reset and silence buttons.

Events in the system, both faults and alarms, are detected and displayed on the LCD. See **11.0 - Alarms and Faults** for more information on events.

- A set of event masks can be configured through the LCD to trigger a system response to an event. See **11.1 - Event Mask**.
- Report event conditions from other components of the system.
- Monitor and report changes in event condition states. If the event condition's state changes from inactive to active, a new event is detected. If the transition is from active to inactive, the event condition has cleared.
- Process new faults and alarms and clear inactive alarms.
- Provide the alarm reset and silence options.

9.2.2 Circuit Breakers and Non-Automatic Circuit Breakers

Input circuit breaker for each source provides over current protection for the Liebert STS2/PDU. Three non-automatic circuit breakers provide total isolation of the solid-state switching devices with an input non-automatic breaker for each source and a load isolation non-automatic breaker. Two non-automatic breakers provide for maintenance bypassing of the solid-state switching devices to either input source.

All breakers in the Liebert STS2/PDU are plug-in types, which allows any breaker to be replaced without de-energizing the output bus. The breakers have an interlock in the plug-in base, which prevents the switch from being withdrawn in the CLOSED position. The switch trips OPEN before it disconnects from the plug-in base.

See **14.2.5 - Circuit Breakers** for specifications and more information pertaining to the circuit breakers. See **Figures 23** through **36** for circuit breaker locations.

The circuit breaker schedule is provided in **Tables 8** through **10**.

9.2.3 SCRs

Brick-type SCRs are used rated to carry the full 100% rated load. The unit is a fuseless design with input circuit breakers providing overcurrent protection.

9.2.4 Logic Modules

The logic contains three separate redundant logic modules. The modules contain the logic necessary to run the Liebert STS2/PDU and control transfers and shunt trips under all circumstances, without any outside assistance once set-up and started properly.

9.2.5 Audible Alarm

An audible alarm is installed on the control board. This alarm is triggered by an alarm condition detected on the unit. The alarm can be turned off from the touch screen. Turning off the audible alarm does not clear or reset the condition that triggered the alarm.

9.2.6 RS-232 Port

An RS-232 serial port is provided to allow an external terminal to be connected as another user interface. See **12.1 - Using the RS-232 Port** for more information.

10.0 OPERATING INSTRUCTIONS

Before unit is placed into service for the first time, after equipment relocation or after the equipment has been de-energized for an extended period, a thorough equipment inspection and supervised startup by qualified personnel are strongly recommended. Contact your local Liebert representative or Liebert Services at 1-800-543-2378 to arrange for equipment inspection and startup.

After the initial equipment startup, the following operating guidelines can be used for standard equipment operation. These guidelines should be reviewed for any special equipment modifications, special site conditions or company policies that may require changes to the standard equipment operation.

All programmable functions are preset at the factory to enable the unit to be brought up without the need to enter all selectable parameters.

The LCD touch screen is discussed in more detail in **13.0 - Touch Screen Display**.

See **Figures 23 through 36** for circuit breaker locations.

10.1 Normal System Turn-On

1. Depending on the type of distribution used:
 - If equipped with output breaker CB8, open CB8.
 - If equipped with output inline panelboards, open panelboard main breakers CB8 and CB9 and, if supplied, CB10 and CB11.
 - If optional subfeed breakers are supplied, open subfeed breakers CB12 and CB13.

See **Figures 3 through 6** for location of breakers.

- a. Retract the bolts on the key interlocks for CB1 and CB2.
 - b. Extend the bolts on the key interlocks for CB4 and CB5, thus preventing CB4 or CB5 from being turned ON.
2. Apply source/input power to both Liebert STS2/PDU inputs by closing CB6 and CB7.
The touch screen control panel should become active and operate properly when at least one of the inputs is energized.
 3. Verify that nominal input voltages are applied to both inputs (Source 1 and Source 2).
The input voltages, selected preferred source, breaker and switch status and alarms are indicated on the Mimic screen.

Figure 58 Liebert STS2/PDU touch screen display

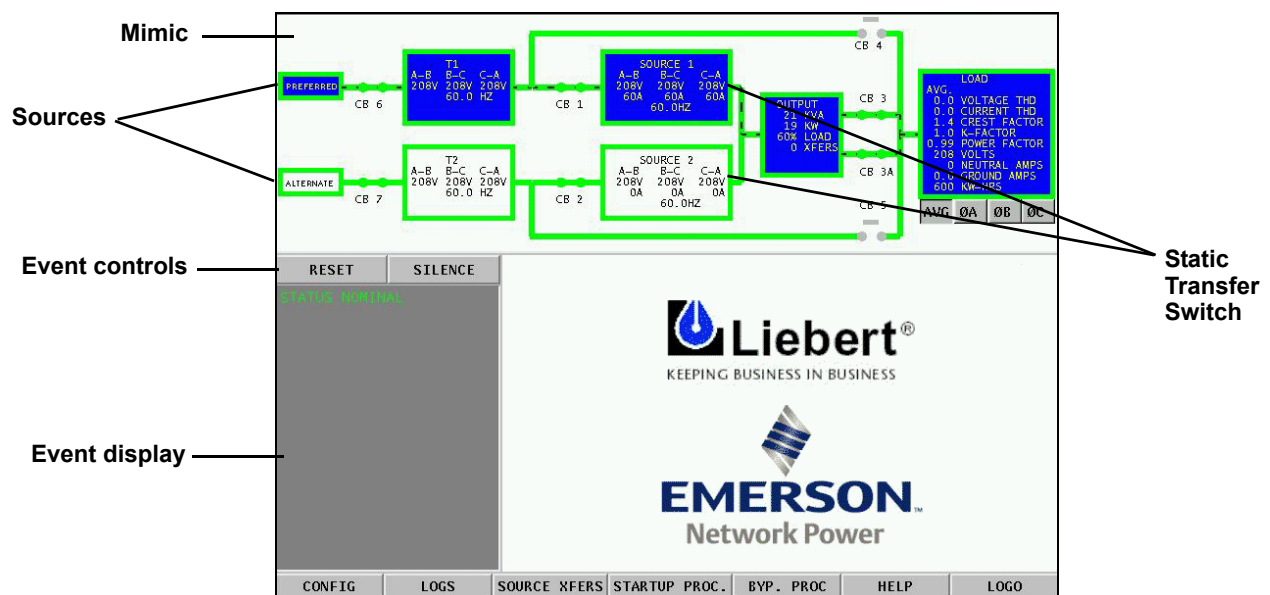

4. Close CB1.
5. Verify that Source 1 voltages are nominal and that CB1 breaker status is correctly indicated on the Monitor/Mimic screen.

6. Close CB2.
7. Verify that Source 2 voltages are nominal and that CB2 breaker status is correctly indicated on the Mimic screen.
8. Verify that boxes for the preferred source and corresponding Liebert STS2/PDU are highlighted on the Mimic screen, indicating which side of the Liebert STS2/PDU is on.
9. Close Output Breaker CB3 (for redundant output configurations, also close CB3A).
10. Verify that CB3, the Output box and the Load box are highlighted, indicating that CB3 is closed and the STS output is energized. On units with I-line panelboard, the panelboard is also energized.



NOTE

For redundant output configurations, CB3 descriptions apply to CB3 and CB3A.

11. Press the RESET button on the touch screen to reset any previous alarms.
12. Check the Event Display and the Mimic to verify there are no active alarms. If any active alarms are displayed, refer to **11.0 - Alarms and Faults** for a description of the alarms and possible causes. Correct all active alarm conditions before proceeding.
13. If unit is equipped with output breaker CB8, close CB8. The output and load are energized.
14. If unit is equipped with output inline panelboards, close panelboard main breakers CB8 and CB9 and, if supplied, CB10 and CB11. Turn on panelboard breakers. If optional subfeed breakers are supplied, close subfeed breakers CB12 and CB13.
15. Turn on the load equipment as directed in the load equipment manufacturer's recommendations.

10.2 Manual Transfer / Preferred Source Selection

The Source Transfer option (Source Xfers) in the touch screen menu allows you to select a preferred source. Transfers are only permitted when the voltage and current are within their proper operating range and the sources are synchronized. The Source Transfer screen indicates the synchronization between the two sources, while the voltage and frequency are displayed on the Mimic. See **Figure 59**. Transfer is inhibited if the deviation exceeds the parameter set in Source Setpoints. See **User Settings on page 100**.



NOTE

*If one source will be de-energized for an extended period (hours or days), set the Liebert STS2/PDU to bypass mode for the remaining source. Without using bypass, if a failure occurs in the switch components for the remaining source, the Liebert STS2/PDU does not have a second source to switch to and the load would not receive power. See **14.2.12 - Maintenance Bypass** for bypass instructions.*

Figure 59 Source Transfer screen

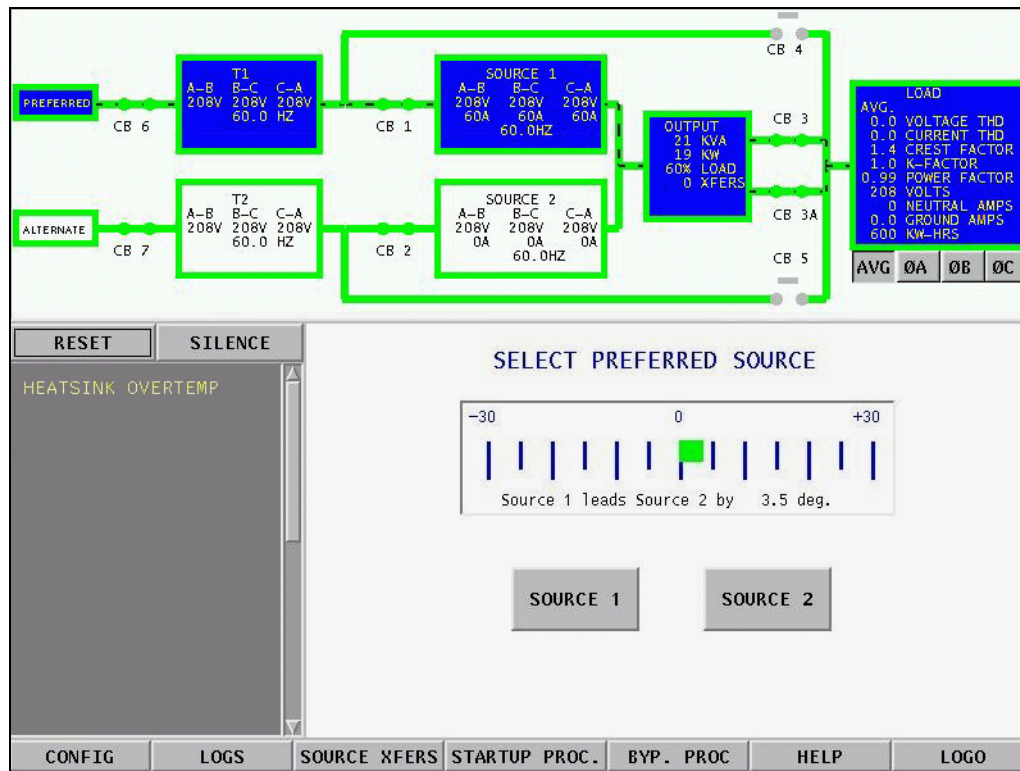

To manually select the preferred source:

1. Close the input breakers CB6, CB7, CB1 and CB2.
2. Select SOURCE XFERS from the menu bar.
The Select Preferred Source screen is displayed in the Event Display.
3. Check the Mimic to verify that Source 1 and Source 2 input voltages are correct.
4. Select SOURCE 1 or SOURCE 2 as your preferred source.
This source is now monitored as the preferred source throughout the various configurations set up through the touch screen.
5. Verify that the correct source is designated as the preferred source and that the input source changes to the desired source.

The Mimic is updated to indicate the new preferred source. The source is now highlighted with blue and that source is labeled as the preferred source. If the Transfer Inhibit message is displayed, check for alarm messages on the Active Status window. Correct alarm conditions before attempting a source transfer.



NOTE

The preferred source may also be changed via the optional Remote Source Selection option, thereby initiating a transfer remotely

10.3 Enabling Remote Source Selection

If your system is equipped with the optional Remote Source Selection option, it must be enabled.

From the Color Graphical Display:

1. Select CONFIG from the menu bar.
2. Select SYSTEM SETTINGS from the Configuration menu.
3. Select SYSTEM OPTIONS from the System Settings menu.
4. Select YES for the REMOTE SOURCE SELECT choice.

10.4 Maintenance Bypass

The Liebert STS2/PDU is equipped with two key-interlocked, bypass breakers, CB4 and CB5, to allow manual bypass of the switch electronics for either input source in the event of switch failure or for maintenance of the switch. Refer to **Figure 3**. While operating on maintenance bypass, all voltages are removed from the static transfer switch electronics to facilitate safe repair, without de-energizing the load using a make-before-break switching sequence.

However, the unit can be bypassed using a make-before-break switching sequence only to the same source to which that the switch is connected, as indicated by the highlighted static transfer switch box on the Mimic screen.

In the event of source or switch failure, the unit should be bypassed only to the current input source. For convenience, instructions for the bypass procedure can be displayed on the touch screen by selecting the BYP. PROC option from the menu bar.

The Mimic is used to verify the status of the unit during the bypass procedures. In the unlikely event that the Color Graphical Display is not available, open the front door and look through the slots in the control door. If you can see green LEDs on the gate driver board through that slot, then the unit is connected to the source referenced on the label below that slot. See **Figure 60**.

Figure 60 Gate board viewing slot locations

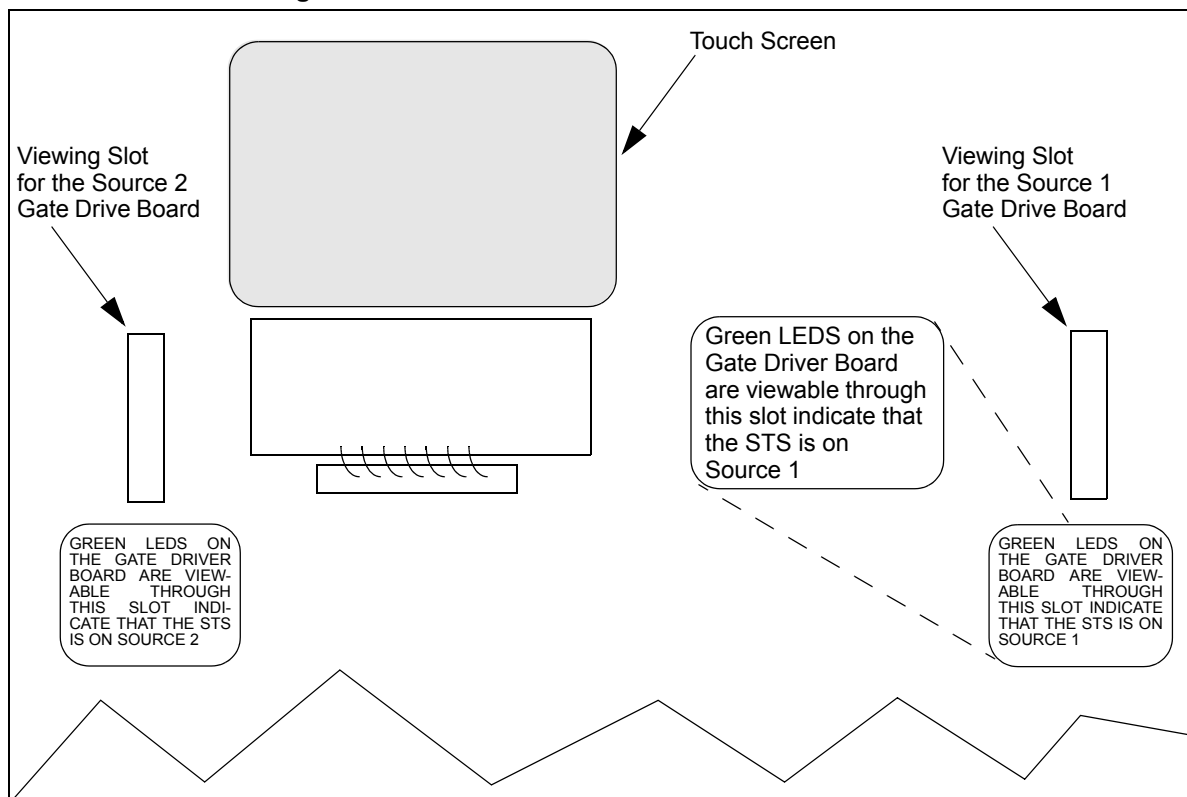

10.4.1 Bypass Procedures for Source 1

To bypass the switch for Source 1:

**NOTE**

If you wish to bypass the Source 1 static transfer switch but Source 2 is presently active, you must first transfer to Source 1. See 10.2 - Manual Transfer / Preferred Source Selection.

1. Verify Source 1 is supplying power via the Mimic.
 - If the Color Graphical Display is not available, check the gate driver board LEDs through the slots in the control panel. See **Figure 60**.
2. Remove interlock key from CB5 and place it in the CB4 interlock.
3. Open the alternate source input breaker CB2.
4. Rotate and remove the interlock key.
5. Insert the key in the CB4 bypass breaker interlock.
6. Rotate interlock keys in CB4 bypass breaker interlock to retract interlock.
7. Close bypass breaker CB4.
8. Verify the breaker status on the Mimic screen.
9. Open source input breaker CB1.
10. Rotate the interlock key and remove it to lockout the breaker.
11. Secure the key, per your site's lockout/tagout procedure.
12. Open output breakers CB3 and CB3A (if supplied) to remove power from static switch.

To return to the normal mode:

1. Remove the key from CB5 and insert it in the CB1 breaker interlock.
2. Rotate key to retract interlock.
3. Close source input breaker CB1.
4. Verify the Source 1 and CB1 breaker status on the Mimic screen.
5. Close output breakers CB3 and CB3A (if supplied).
6. Verify CB3 and CB3A breaker status and STS SOURCE 1 and OUTPUT boxes are highlighted on the Mimic screen.
7. Open bypass breaker CB4.
8. Rotate the keys in CB4 interlock to extend the interlock.
9. Remove the proper key from CB4 interlock and insert it into CB2 breaker interlock.
10. Rotate the key to retract the CB2 breaker interlock.
11. Close source input breaker CB2.
12. Verify the STS SOURCE 2 box and CB2 breaker status on the Mimic screen.
 - If the Color Graphical Display is not available, check the gate driver board LEDs through the slots in the control panel. See **Figure 60**.

10.4.2 Bypass Procedures for Source 2

To bypass the switch for Source 2:



NOTE

If you wish to bypass the Source 2 static transfer switch but Source 1 is presently active, you must first transfer to Source 2. See 10.2 - Manual Transfer / Preferred Source Selection.

1. Verify Source 2 is supplying power via the Mimic.
 - If the Color Graphical Display is not available, check the gate driver board LEDs through the slots in the control panel. See **Figure 60**.
2. Remove the interlock key from CB4 and place it in CB5 interlock.
3. Open the alternate source input breaker CB1.
4. Rotate and remove the interlock key.
5. Insert the key in the CB5 bypass breaker interlock.
6. Rotate interlock keys in the CB5 bypass breaker interlock to retract the interlock.
7. Close bypass breaker CB5.
8. Verify the breaker status on the Mimic screen.
9. Open source input breaker CB2.
10. Rotate the interlock key and remove it to lockout the breaker.
11. Secure the key, per your site's lockout/tagout procedure.
12. Open output breakers CB3 and CB3A (if supplied) to remove power from static switch.

To return to normal mode:

1. Insert the key in the CB2 breaker interlock.
2. Rotate the key to retract the interlock.
3. Close source input breaker CB2.
4. Verify Source 2 and CB2 breaker status on the Mimic screen.
5. Close output breakers CB3 and CB3A (if supplied).
6. Verify CB3 and CB3A breaker status and STS SOURCE 2 and OUTPUT boxes are highlighted on the Mimic screen.
7. Open bypass breaker CB5.
8. Rotate the keys in CB5 interlock to extend the interlock.
9. Remove the proper key from CB5 interlock and insert it into CB1 breaker interlock.
10. Rotate the key to retract the CB1 breaker interlock.
11. Close source input breaker CB1.
12. Verify the STS SOURCE 1 box and CB1 breaker status on the Mimic screen.
 - If the Color Graphical Display is not available, check the gate driver board LEDs through the slots in the control panel. See **Figure 60**.

10.5 Normal System Shutdown

The Liebert STS2/PDU can be shut down from either the static switch mode or the bypass mode.

10.5.1 Shutdown in Static Transfer Switch Mode

When the Liebert STS2/PDU is operating on static transfer switch mode (not maintenance bypass mode):

1. Turn off the load equipment per manufacturer's recommendations.
2. Open CB8 or panelboard breakers and mains if supplied
3. Open CB3 to turn off the static switch output.
 - Open CB3A if the Liebert STS2/PDU has a redundant output configuration.
4. Open the input switches CB1 and CB2.
5. To completely de-energize the unit, open CB6 and CB7.

10.5.2 Shutdown in Maintenance Bypass Mode

When the Liebert STS2/PDU is operating on bypass:

1. Turn off the load equipment per manufacturer's recommendations.
2. Open CB8 or panelboard breakers and main if supplied
3. Open the bypass switch (CB4 or CB5) to turn off the static transfer switch output.
4. To completely de-energize the unit, turn open CB6 and CB7.

11.0 ALARMS AND FAULTS

Alarms and faults are events that are triggered when the operation of the Liebert STS2/PDU falls outside of the defined parameters. These events can also be triggered by: user actions, such as changing configurations, clearing logs, etc.; failed components such as a fan failure, an SCR that is open or shorted, etc.; and system status, such as open circuit breakers, load on alternate source, etc. These events can provide a warning or trigger the system to make a change, such as switch sources or the recording of a history log.

The Liebert STS2/PDU monitoring system detects and annunciates a comprehensive set of fault and alarm conditions. Faults and alarm messages are can be viewed on the LCD touch screen or via the RS-232 port.

On the LCD touch screen, the events are shown in the Status Display panel in the lower left corner of the touch screen and written to the Event log. You can touch a message to view a definition of an event and a tip for troubleshooting. See **13.0 - Touch Screen Display** for more information about the touch screen.

If you are monitoring the system through the RS-232 port, see **Table 12** for the commands to view event logs and alarm and fault lists.

Event actions can be triggered by the settings configured from the Event Masks. See **11.1 - Event Mask** for more information.

Faults — A fault indicates that a component of the Liebert STS2/PDU has failed or has been damaged. In the Event Display, faults are indicated in red.

Alarms — An alarm is an event caused by a significant abnormal system condition. In the Event Display, alarms are indicated in yellow. The setpoints for many of the alarms are configurable through the User Settings. Many alarms clear themselves when the condition is resolved. If an alarm event mask is set to latch, the alarm messages remain active until the alarm condition has been corrected and the RESET button is pushed. See **11.1 - Event Mask** for more information on latching.

When the system is equipped with an external modem and a telephone line is connected to the modem, the system can be programmed to automatically dial out upon occurrence of any of certain designated alarms. The auto-dial feature can be configured for alarms using the Event Mask option in the touch screen. See **Configuring the Modem on page 105** for instructions on for setting up a modem.

11.1 Event Mask

The Liebert STS2/PDU gathers, processes and reports faults and alarms, collectively referred to below as events. The Event Mask dialog box allows you to set the system's response for specific alarms and faults that are generated.

The following mask types are available for each event:

- **Latch** — If a latch is enabled for the selected event, that event remains active even if the originating event condition clears. A latched event may only be cleared by pushing the RESET button.
- **Dial Out** — If the selected event is triggered, the system automatically calls the specified telephone numbers through a modem. For example, a page could be sent or an event could be sent to a external terminal, via a modem. See **12.0 - Communication Interfaces** for more information on configuring communications options.
- **Event Log** — The selected event is date/time stamped and recorded to the Event Log when the event is triggered.
- **Audible** — If the selected event is triggered, an audible beeper or horn is sounded by the Liebert STS2/PDU. The beeper continues while this event is active or latched or until the SILENCE button is pushed.

See **Event Masks on page 99** for instructions on setting the mask type via the touch screen display. See the **12.1.4 - Setting Event Masks with the Terminal** for instructions on configuration using the RS-232 port.

11.2 Event and History Logs

The system tracks events through the Events Log and tracks significant events through the History Logs. These logs allow you to quickly spot trends or diagnose problems that the unit may have had. Both logs are written in nonvolatile memory.

The logs can be accessed from the touch screen menu or the RS-232 port. See **13.7.1 - Logs** for more instructions on viewing the logs from the touch screen. See **Table 12** for the RS-232 interface commands used to access the logs.

11.2.1 Event Log

The events are tracked in sequence of occurrence. The sequence of occurrence is identified by date, time and frame number. The last 512 events are stored in a nonvolatile memory and can be viewed from the Event Log.

Event logs wrap, meaning when the log is full, the oldest event is deleted when a new event is written to the log.

The Event Log tracks:

- # — the sequence number in which the event occurred since the log was last cleared.
- Message — the event that occurred, such as Ambient Over temp., Source 1 Fail, etc.
- Type — either a Fault or Alarm. See **11.0 - Alarms and Faults** for further details on these events.
- ID — the event identifier.
- Date and Time — when the event occurred.
- Faults — the number of fault events logged.
- Alarms — the number of alarm events logged.
- User Alarms — the number of alarm events logged that were triggered by user-created alarms, such as those alarms created with the Input Contact Isolator settings.
- Total — the sum of all the events currently logged.

11.2.2 History Log

When a designated major alarm occurs, the History Status buffer is frozen, capturing 64 sequential frames before and after the alarm condition. When the History Status buffer is frozen, a History Log is created.

Two History Logs are available to track major alarms. This log includes the triggering event plus the surrounding events and the system voltages, currents, frequency, power, source selection and breaker positions at the time of the event. The History Log displays the 64 sequential frames, in 4-millisecond intervals, of the Present Status screens surrounding the event.

If you are viewing the log from the touch screen, the Mimic and the Event Display show the data that was present as the alarm was triggered. The data is displayed as frames are played.

The History Log allows you to replay the events leading up to the alarm and the events right after the alarm to see the status of the switch at that time and diagnose the cause of the alarm. The History Log is triggered when certain events are tripped that have the Freeze option enabled.

You can run through the frames sequentially. The sequence of the events is identified by date, time and frame number. The History Log frames are stored in a nonvolatile memory buffer that is continuously overwritten until a designated fault condition occurs. When the fault occurs to trigger a freeze, the History Log stores the next 23 frames, then freezes until it is reset. The History Log then keeps 40 frames before the fault, the frame where the fault occurred, plus the next 23 frames.

The History Log should not be reset until the fault condition that caused the buffer to freeze is reviewed and investigated by a qualified service technician. After the alarm condition has been corrected, the History Log can be cleared.

The History Log has the following fields:

- **Replay Rate** — indicates how long it takes for the replay to play. Use the UP and DOWN buttons to set the time.
- **Status** — the status of the Liebert STS2/PDU at the point of the current frame in the replay. The History log has three statuses: Frozen, Not Frozen and Retrieving Data, please stand by.
- **Critical Event** — The event which triggered this log to be written. The event is indicated in red on the bar graph.
- **Frame Number** — the current frame in the replay. A negative number indicates the replay is at a point before the triggering event occurred.

11.3 Alarm Notes

The I-PK on Source 1 and I-PK on Source 2 alarms inhibit automatic transfer due to an overload or load fault. These alarms can be set for either auto or manual alarm reset.

In the auto reset mode, the alarm is reset as soon as the load current and source voltage return to are inhibited until the conditions return to normal and the user manually presses the RESET button. In either case, the cause of the Source 1 or Source 2 Ipeak overload should be investigated and resolved (such as by reducing the overload condition or clearing the output fault) before returning the switch to normal operation.

These events indicate a device failure. The device must be replaced and the system must be restarted for the fault to clear. A shorted SCR automatically trips open a source input switch (CB1 or CB2) to prevent transfers in the event of an SCR failure. The SCR failure must be investigated and repaired before returning the switch to normal operation. Both source input switches must be opened (such as when the unit is placed in maintenance bypass for servicing) before a shorted or open SCR alarm can be reset.

11.4 List of Messages

Table 11 lists available event messages, a definition of the event and the functions that are activated with the event by default. The functions are indicated as follows:

- D** — The indicated event initiates the **Auto-Dial** sequence through the optional modem.
- A** — The indicated event activates the **Audible** alarm.
- F** — The indicated event triggers a **Freeze** of the History Log.
- L** — The indicated event **Latches**. A latched alarm remains displayed until the alarm condition has cleared and the RESET button has been pressed.
- E** — By default, all faults and alarms are written to the Event Log. See **12.1.4 - Setting Event Masks with the Terminal**.

All of these functions, except Freeze, can be reconfigured to trigger for each event, using the Event Mask option. See **11.1 - Event Mask**. The Freeze function is hard-coded and cannot be changed for a event.

Table 11 Event messages

ID	Alarm Message	Description/Cause	Action
1	S1 SCR SHORT	One or more of the SCRs for Source 1 have shorted and failed.	D, F, A, E
2	S2 SCR SHORT	One or more of the SCRs for Source 2 have shorted and failed.	D, F, A, E
3	S1 SCR OPEN	One or more of the SCRs for Source 1 is open.	D, F, A, E
4	S2 SCR OPEN	One or more of the SCRs for Source 2 is open.	D, F, A, E
5	PRIMARY FAN FAIL	A primary cooling fan has failed and the unit is now being cooled by a secondary fan, which is not monitored.	D, A, E
6	CONTROL MODULE FAIL	Control logic module has failed.	D, A, E
7	PWR SPLY DC A FAIL	Power supply DC bus A has failed.	D, A, E
8	PWR SPLY DC B FAIL	Power supply DC bus B has failed.	D, A, E
9	PWR SPLY S1 AC FAIL	Power supply Source 1 AC has failed.	D, A, E
10	PWR SPLY S2 AC FAIL	Power supply Source 2 AC has failed.	D, A, E
11	PWR SPLY LOGIC FAIL	A power supply module has failed.	D, A, E
12	OUT VOLT SENSE FAIL	The output volt sense module failed	D, A, E
13	S1 VOLT SENSE FAIL	The Source 1 volt sense module failed.	D, A, E
14	S2 VOLT SENSE FAIL	The Source 2 volt sense module failed.	D, A, E
15	S1 SCR SENSE FAIL	The Source 1 SCR sense module failed.	D, A, E
16	S2 SCR SENSE FAIL	The Source 2 SCR sense module failed.	D, A, E
17	S1 CURR SENSE FAIL	The Source 1 SCR current module failed.	D, A, E
18	S2 CURR SENSE FAIL	The Source 2 SCR current module failed.	D, A, E
19	S1 GATE DRIVE FAIL	The Source 1 gate drive module failed.	D, A, E
20	S2 GATE DRIVE FAIL	The Source 2 gate drive module failed.	D, A, E
21	INTERNAL COMM FAIL	Internal CAN communications failed.	D, A, E
23	CB1 SHUNT TRIP FAIL	CB1 shunt trip failed.	D, A, E
24	CB2 SHUNT TRIP FAIL	CB2 shunt trip failed.	D, A, E
27	EQUIPMENT FAN FAIL	One of the equipment fans failed	D, A, E
28	INPUT 1 SURGE FAIL	Source 1 input surge suppression module failed	D, A, E
29	INPUT 2 SURGE FAIL	Source 2 input surge suppression module failed	D, A, E
64	HEATSINK OVERTEMP	Heatsink has exceeded the recommended temperature.	A, E
65	EQUIPMENT OVERTEMP	Cabinet has exceeded the recommended temperature	A, E
67	S1 UV	Source 1 under voltage, fast detection.	A, E
68	S1 UV (RMS)	Source 1 under voltage, slow detection.	A, E
69	S1 OV	Source 1 over voltage	A, E
70	S1 OF/UF	Source 1 over frequency/under frequency	A, E
71	S1 FAIL	Source 1 failure.	A, E
72	S2 UV	Source 2 under voltage, fast detection.	A, E
73	S2 UV (RMS)	Source 2 under voltage, slow detection.	A, E
74	S2 OV	Source 2 over voltage.	A, E
75	S2 OF/UF	Source 2 over frequency/under frequency.	A, E
76	S2 FAIL	Source 2 failure.	A, E
77	S1 OVERCURRENT	Source 1 over current.	A, E
78	S2 OVERCURRENT	Source 2 over current.	A, E
79	S1 I-PEAK	I-PK on Source 1.	D, F, A, E
80	S2 I-PEAK	I-PK on Source 2.	D, F, A, E

Table 11 Event messages (continued)

ID	Alarm Message	Description/Cause	Action
81	SOURCES OUT OF SYNC	Source 1 and Source 2 are out of synchronization.	A, E
82	LOAD ON ALT SOURCE	The output load is running on the alternate source.	A, E
83	AUTO REXFER INHIBIT	Automatic retransfer is inhibited.	A, E
84	CB1 (S1) OPEN	Source 1, Circuit Breaker 1 is open.	A, E
85	CB2 (S2) OPEN	Source 2, Circuit Breaker 2 is open.	A, E
86	CB4 (S1 BYP) CLOSED	Source 1 on bypass, Circuit Breaker 4 is closed.	A, E
87	CB5 (S2 BYP) CLOSED	Source 2 on bypass, Circuit Breaker 5 is closed.	A, E
88	CB3 (OUTPUT) OPEN	Output circuit breaker (CB3) is open.	A, E
89	CB3A (OUTPUT) OPEN	Output circuit breaker (CB3A) is open.	A, E
90	S1 PHASE ROT ERROR	Source 1 phase rotation error.	A, E
91	S2 PHASE ROT ERROR	Source 2 phase rotation error.	A, E
92	TRANSFER INHIBITED	Transfer inhibited.	A, E
93	OUTPUT UV	Output is under voltage.	D, F, A, E
94	HISTORY LOG FULL	Both History Logs have been written and no more history logs can be written without clearing one of the logs	A, E
96	INPUT 1 OV INPUT	Source 1 over voltage	A, E
97	INPUT 1 UV INPUT	Source 1 under voltage	A, E
98	INPUT 2 OV INPUT	Source 2 over voltage	A, E
99	INPUT 2 UV INPUT	Source 2 under voltage	A, E
100	LOAD OVERCURRENT	Output over current	A, E
101	GROUND OVERCURRENT	Ground over current	A, E
102	NEUTRAL OVERCURRENT	Neutral over current	A, E
103	LOAD VOLTAGE THD	Voltage THD has exceeded the set limit	A, E
104	INPUT 1 CB6 OPEN	Source 1 input Circuit Breaker 6 is open	A, E
105	INPUT 2 CB7 OPEN	Source 2 Input Circuit Breaker 7 is open	A, E
106	INPUT 1 OF/UF	Source 1 over frequency/under frequency	A, E
107	INPUT 2 OF/UF	Source 2 over frequency/under frequency	A, E
120 121 122 123 124 125 126 127	INPUT CONTACT #1 INPUT CONTACT #2 INPUT CONTACT #3 INPUT CONTACT #4 INPUT CONTACT #5 INPUT CONTACT #6 INPUT CONTACT #7 INPUT CONTACT #8	Input Contact # x is an optional alarm input. The alarm name can be programmed with an alarm name from the Input Contactor Isolator settings option under the Comm Options. See Configuring the Input Contact Isolator Settings on page 106 . The alarm is sent to Monitor DSP. The LCD logs the alarm with the programmed name. Monitor DSP logs it with the generic name which is how it is reported to the SVT query.	A, E
128	CONFIG MODIFIED	A setpoint configuration has changed.	E
129	PASSWORD CHANGED	The password for touch screen access has been modified and saved.	E
130	TIME REPROGRAMMED	The system's time has been reset and saved.	E
131	DATE REPROGRAMMED	The system's date has been reset and saved.	E
132	EVENT LOG CLEARED	The event log has been erased.	E
133	HIST LOGS CLEARED	Both History Logs have been erased.	E
134	XFER COUNT CLEARED	Transfer counter reset to 0	E
135	KWH COUNT CLEARED	KW-Hrs counter reset to 0	E

12.0 COMMUNICATION INTERFACES

The Liebert STS2/PDU monitoring system offers several choices for communications.

The RS-232 terminal port is standard on all units. The port is inside the front door, to the left of the touch screen front panel mounting as shown in **Figure 54**. This port is primarily used as an alternate user interface to configure, control and diagnose the system. Commands for the RS-232 port are shown in **Table 12**.

Several other communications options are also available. Those options are located a Communications compartment. See **Figures 47** and **48** for the location of the communications options.

Connections to the communication ports are made by wiring to terminal boards located in the Communications compartment. The communications options listed below reference the control wiring drawing for each option.

- Liebert IntelliSlot Web/485 Card With Adapter (IS-WEB485ADPT) (optional) — the Liebert IS-WEB485ADPT provides connectivity to any TCP/IP-based Ethernet network to allow the device to communicate with network management systems (NMS) via SNMP. Events can be transmitted to the NMS to provide remote status monitoring, plus fault and alarm detection. The Liebert IS-WEB485ADPT includes an RJ-45 port for an Ethernet connection, via Category 5 cable.

The Liebert IS-WEB485ADPT can also integrate the system with an existing Building Management System (BMS) or out-of-band monitoring, using Modbus, a standard multi-drop protocol. The card has redundant communication paths that make it possible to connect to a BMS using Modbus while simultaneously communicate to a NMS through SNMP.

See **Figure 53** for more information on the Liebert IS-WEB485ADPT. If you have questions about the Liebert IS-WEB485ADPT, refer to the user guide, SL-52615, available at Liebert's Web site, www.liebert.com

- Input Contact Isolator (ICI) Board (optional) — provides an interface for up to eight user inputs. External messages and alarms can be routed to the unit, via the ICI. See **Configuring the Input Contact Isolator Settings on page 106** for instructions on configuring the connections. See **Figure 51** for wiring details.
- Programmable relay board (PRB) (optional) — up to two PRBs can be installed in the Liebert STS2/PDU to route Liebert STS2/PDU events to external devices. See **Configuring the Programmable Relay Board Settings on page 108** for default settings and instructions for reconfiguring the relays. See **Figure 50** for wiring details.
- Comms Board (optional) — includes a terminal block to provide a DTE connection to an external modem. This board also provides a direct connection to a Liebert SiteScan terminal, via an RS-422.

Liebert SiteLink-12 or Liebert SiteLink-4 is required for Liebert SiteScan to communicate with the Liebert STS2/PDU. See **Figure 52** for wiring details.

Data link requirements are Full Duplex Asynchronous RS-232 format.

Communications options are also discussed in **6.0 - Options**.

12.1 Using the RS-232 Port

The RS-232 port is configured with a baud rate of 9600 with 8 Data Bits, 1 Stop Bit, No Parity and no hardware handshaking.

12.1.1 Connecting and Using a Terminal

An RS-232 connection can be used to connect the Liebert STS2/PDU to either a terminal or a PC running terminal emulation software. If unsure of the cable pin out, see **14.2.10 - Terminal Port Connections**.

1. Connect the terminal to the Liebert STS2/PDU by plugging the cable from the terminal into the RS-232 port. This connection can be made at any time.
2. After making the connection, verify the communications link by pressing <ENTER> on the terminal keyboard.

The interface communications system responds as indicated below:

Repeating command -->

Illegal command!

<?> or <HELP?> displays the RS-232 command set

<?> <command> or <HELP?> <command> displays specific help for the command SVTP-Control>

The SVTP-Control > prompt indicates that RS-232 communications are established.

- If you receive no response or prompt, verify that the connector is properly plugged into the port and the PC or terminal serial interface is working properly.
3. Enter the desired commands, as listed in **Table 12**.

For additional help type <?> <command> or <HELP?> <command>

Refer to the corresponding menu options in **13.0 - Touch Screen Display** for more details about the commands.

Some terminal commands require a password to function. Use the PWD command and a valid password to gain access.

Table 12 Terminal commands

Keys	Function
?	Displays this help menu or specific help with a command
AA?	Displays active alarms
AF?	Displays active faults
CEL	Clears the event log
CHL	Clears the history logs
DATE?	Displays current system date
DATE	Sets system date
EL?	Displays the entire event log
HELP?	Displays this help menu or specific help with a command
HLn?	Displays the history log #n, if frozen
LOGOUT	Logs user out of unprotected mode
PS?	Displays the preferred source
PS n	Sets the preferred source to #n
PWD	Allows users to access protected commands
QUIT	Modem only. Ends the session and hangs up the modem.
SH	Silences the horn
SPT?	Displays all current setpoints
SPTx	Displays current setpoints for group x. See 12.1.2 - Configuring the Liebert STS2/PDU via the Terminal for a description of groups.
SR?	Displays status reports
TIME?	Displays current system time
TIME	Sets system time
UPMDR?	Displays metering data
VER?	Displays firmware versions

12.1.2 Configuring the Liebert STS2/PDU via the Terminal

The SPT command is used to configure the systems setpoints. The SVT syntax for the setpoints consists for four parameters:

SPT [group] [item] [value] where the parameters are:

- SPT — is the terminal command that is used to configure setpoints.
- group — the group under the setpoint command which contains the desired settings.
- item — the item number within the selected group.
- value — the desired value for this item.

Only the specific options words listed in this section use a hexadecimal value. Other settings, depending on what they are, use other input types. For example, System ID uses a text string; nominal voltages and currents use standard numeric integers; and modem baud rate uses an enumeration where

0 = 2400, 1 = 9600, & 2 = 19200 bps.



NOTE

Spaces are placed between each parameter, but not between characters or numbers in a parameter. Using an underline here to represent a space, an example of a the syntax is: SPT_2_6_0081. The value parameter is 0081.

This section provides instructions for setting these parameters, with an example of building an SPT command for System and User settings.

Groups Parameter

The setpoints are grouped for ease of configuration. For example, Event Masks are group 4 and System Settings are group 2. The numbers shown below are entered for the group parameter. For example, start of a System Settings command is SPT 2.

The group parameters are:

- 1 = System Ratings
- 2 = System Settings
- 3 = User Settings
- 4 = Event Mask Settings

For example, the start of a System Settings command is SPT 2, where SPT is the system setpoints command and 2 is the group parameter for System Settings.

See **12.1.4 - Setting Event Masks with the Terminal** for instructions on configuring Event Mask parameters.

Item Parameter

Each setting within the group is indexed by an item number as shown below in **Table 14**. These item numbers are also displayed on the terminal when you list the configuration setting for a particular group.

Continuing with the example, to configure an Options_1 setting under System Settings, the command would begin with SPT 2 6 where 6 is the value Options_1. Note the space between each parameter.

Value Parameter

Item settings, depending on what they are, use various value types. **Table 13** provides a list of the possible value types and their description.

Table 13 Value types

Type	Definition
Numeric	An integer numeric value in the units indicated by the item name. For example, a System Voltage Rating of <i>480</i> would indicate <i>480 volts</i> .
Scaled	Similar to the Numeric, this value type is an integer that has been scaled, usually to remove decimal points that would normally appear within the value. In this case, a value of <i>2.5</i> may actually be input as simply <i>25</i> . For all Scaled types, the scaling appears in Table 14 .
String	Certain settings are represented by alphanumeric character strings, such as setting the System Model Number to <i>ProductName</i> .
Enumeration	This type uses an indexed list to represent possible choices. One example is the Modem Baud Rate which uses a value of <i>0</i> to select 2400 bps, <i>1</i> for 9600 bps and <i>2</i> for 19200 bps.
Bit-packed	This type of value uses a <i>hexadecimal binary word</i> , where each of the sixteen <i>bits</i> in the word has the value of <i>1 (True)</i> or <i>0 (False)</i> . Although somewhat difficult to use, it packs a large amount of data within a single entry. A detailed description of this type appears in section 12.1.3 - Setting Bitpacked Options With the Terminal .
Event Masks	This type is a specially formatted and is used to customize the behavior of each fault and alarm in the system. See 12.1.4 - Setting Event Masks with the Terminal for instructions on configuring Event Mask parameters.

Table 14 shows the various groups, the settings contained within and the type of value it requires.

Table 14 Group settings and values

Group	Item:	Description	Value Type	Value Notes
Group 1: System Ratings	1	Input Volts (PDU)	Integer	Set per system spec.
	2	Volts	Integer	Set per system spec.
	3	Current	Integer	Set per system spec.
	4	Frequency	Scaled	Desired freq. x 10 (600 = 60 Hz)
Group 2: System Settings	1	Language	Enumeration	[Not supported at this time]
	2	System Model Number	String	14 Character max.
	3	System ID Number	String	8 Character max.
	4	System Tag Number	String	8 Character max.
	5	System Order Number	String	8 Character max.
	6	Options_1	Bitpacked	14 Character max.
	7	Autodial Primary Line	String	20 Character max.
	8	Autodial Secondary Line	String	20 Character max.
	9	Autodial Pager Number	String	20 Character max.
	10	Autodial Pager PIN	String	10 Character max.
	11	Modem Init String	String	20 Character max.
	12	Modem Baud Rate	Enumeration	0 = 2400, 1 = 9600, & 2 = 19200 bps
	13	Modem LGS Check - Day	Bitpacked	
	14	Modem LGS Check - Time	Bitpacked	
	15	Comms Options 1	Bitpacked	See section 12.1.3.
	16	Comms Options 2	Bitpacked	See section 12.1.3.
Group 3: User Settings	1	SRC1 Fast Undervoltage Setpoint	Integer	In % of nominal below nominal
	2	SRC1 Slow Undervoltage Setpoint	Integer	In % of nominal below nominal
	3	SRC1 Slow Undervoltage Detect Delay	Integer	In number of lines cycles
	4	SRC1 Overvoltage Setpoint	Integer	In % of nominal above nominal
	5	SRC1 Overvoltage Detect Delay	Integer	In 1/4 lines cycles
	6	SRC1 I peak Transfer Setpoint	Integer	x 10
	7	SRC2 Fast Undervoltage Setpoint	Integer	In % of nominal below nominal
	8	SRC2 Slow Undervoltage Setpoint	Integer	In % of nominal below nominal
	9	SRC2 Slow Undervoltage Detect Delay	Integer	In number of lines cycles
	10	SRC2 Overvoltage Setpoint	Integer	In % of nominal above nominal
	11	SRC2 Overvoltage Detect Delay	Integer	In 1/4 lines cycles
	12	SRC2 I peak Transfer Setpoint	Integer	x 10
	13	Max. Transfer Phase Angle	Integer	In degrees
	14	Output Frequency Deviation	Integer	Freq. in Hz x 10
	15	ReTransfer Delay Time	Integer	In seconds
	16	Horn Volume	Integer	Range: 1-10
	17	Critical Option Enabling	Bitpacked	See section 12.1.3.
	18	Non-Critical Option Enabling	Bitpacked	See section 12.1.3.
Group 4: Event Mask Settings	1 to 63	Event Mask settings for faults	Event Mask	See section 12.1.3.
	64 to 143	Event Mask settings for alarms	Event Mask	See section 12.1.3.

12.1.3 Setting Bitpacked Options With the Terminal

Five sets of options and features settings are available through the terminal to control the system operation.

Under System Settings for the SPT command, these items denote which options are INSTALLED:

- 6 — Options_1
- 14 — Comms Options 1
- 15 — Comms Options 2

Under User Settings, for the SPT command, these items denote which features are ENABLED:

- 17 — Critical Option Enabling
- 18 — Non-Critical Option Enabling

The value parameter settings are in the form of a bit-packed word (in hexadecimal notation). In other words, each bit indicates a particular setting for the option or feature. The bit assignments for the options and features are as follows:

Options_1

- bit0 — HasDualOutputBreaker
- bit1 — HasPDU
- bit2 — Has4PoleTransferSwitch
- bit3 — HasShuntTrip
- bit4 — HasWyeOutputXfmr
- bit5 — HasExternalPrecisionTimeSource
- bit6 — HasSFA
- bit7 — HasRemoteSourceSelect
- bit8 through bit15 — not used (set to 0)

Comms Options 1

- bit0 — HasIntModem
- bit1 — HasExtModem
- bit2 — HasNIC
- bit3 — not used (set to 0)
- bit4 — HasSiteScan
- bit5 — not used (set to 0)
- bit6 — not used (set to 0)
- bit7 — HasOpenCommsDigitalInputBrd
- bit8 — HasOpenCommsDigitalOutputBrd_1
- bit9 — HasOpenCommsDigitalOutputBrd_2
- bit10 — HasRemoteStatusPanelBrd_1
- bit11 — not used (set to 0)
- bit12 — not used (set to 0)
- bit13 — not used (set to 0)
- bit14 — EnableDialIn
- bit15 — EnableDialOut

Comms Options 2

- bit0 — EnablePager
- bit1 — EnableOCDINormallyClosed
- bit2-3 — OCDO1Assignment (0=User Defined, 1=Standard Set or 2=AS400)
- bit4-5 — OCDO2Assignment (0=User Defined, 1=Standard Set or 2=AS400)
- bit6 through bit15 — not used (set to 0)

Critical Option Enabling

- bit0—EnableManual_IPeakReset
- bit1—EnableAutoRestart
- bit2 through bit15 - not used (set to 0)

Non-Critical Option Enab

- bit0 — EnableAutoReXfer
- bit1 through bit15 — not used (set to 0)

The bits are set in reverse order, from bit 15 on the left to bit 0 (zero) on the right. The bits are grouped in four sets of four bits each, as such:

```
0000 0000 0000 0000
|.....|
bit 15.....bit 0
```

Since each bit represents a setting, a bit can be enabled or disabled:

- 1 = installed option or enabled feature
- OR
- 0 = option not installed or feature not enabled

Enabling or disabling the bits in each group creates a binary value for that group. For example, if the fourth bit in a group is set to 1, the group's binary value is 0001.

Each group is translated into a hexadecimal equivalent. The group with the value of 0001 has a hex equivalent of 1.

You can use **Table 15** below to help with the conversion.

Table 15 Binary-hexadecimal conversions

Binary Value	Hex Equivalent
0000	0
0001	1
0010	2
0011	3
0100	4
0101	5
0110	6
0111	7
1000	8
1001	9
1010	A
1011	B
1100	C
1101	D
1110	E
1111	F

The hex value for each group is entered in the command as four digits.

To summarize the procedure:

1. Set each bit position.
2. Convert the binary value each group into its hex equivalent.
3. Enter the hex values for each group, in order, into the command for the value parameter.

The following example explains how the conversion is completed.

Putting the Terminal Command Together

For example, a unit only has the Remote Source Selection and Dual-Output Breaker options installed.

Checking the bits list under **Options_1 on page 91**, bits 7 and 0 each must be set to 1 to indicate that these options are installed.

The bit setting is as follows, starting with bit 15 on the left and going down to bit 0:

```
0000 0000 1000 0001
```

With the bits combined in groups of four, the binary settings can be translated into hexadecimal values.

The first two groups in the sample equal zero (0). In the third group, 1000 in binary translates to 8 in hex. In the fourth group, 0001 in binary translates to 1 in hex.

In hex, this equates to (digits in the value parameter cannot have spaces between them):

```
0081
```

So your command to indicate that the Remote Source Selection and the Dual-Output Breaker are installed would be:

```
SPT 2 6 0081
```

12.1.4 Setting Event Masks with the Terminal

The event masks can be customized via a terminal. The command `SPT4?<ENTER>` displays all faults and alarms, along with their associated event masks. A plus sign (+) means that particular event mask is enabled, while a minus sign (-) means that mask is disabled.

Refer to **11.1 - Event Mask** for more information on event masks and their associated flags.

Unlike the System and User Settings, mask values are set by designated letters, not hex values.

However, as with other RS-232 interface settings, four parameters are passed. See **12.1.2 - Configuring the Liebert STS2/PDU via the Terminal** for more details about the parameters.

The syntax for configuring event masks is:

```
SPT 4 ID ±D±L±S±E±A
```

- SPT — is the terminal command used to configure setpoints.
- 4 — setting (group parameter) for event masks, under System Settings.
- ID — event ID. The ID is the item parameter for this command. The ID numbers for each event are listed with the events in **Table 11**.
- D,L,S,E,A — the event masks: Dial, Latch, Summary, Event log and Audible. The masks are the value parameter for the command.

Each mask type must be preceded by a plus sign (+) to enable it or by a minus sign (-) to disable it.



NOTE

NO spaces are placed between each mask listed above.

Only the mask that is passed (enabled) is applied when the event occurs.

To set the event masks for a particular event:

1. Enter the command. Examples and descriptions are provided below.
2. Press ENTER.

After the new settings are entered, the new results for that event ID are displayed.

Examples of Event Mask Settings

- To latch event #001, S1 SCR SHORT, use SPT 4 1 +L.
- To disable event #128, CONFIG MODIFIED, from sounding the horn, use SPT 4 100 -A.
- To enable event #012, OUT VOLT SENSE FAIL, to Dial and go into the Event Log, use SPT 4 12 +D+E.
- To disable all masks for event #120, INPUT CONTACT #1, use SPT 4 120 -D-L-S-E-A.
- To breakdown this syntax for the last example:
- SPT — SVT command
- 4 — group parameter, identifying System Setting group under which the Event Mask settings reside.
- 120 — item parameter. In this command, that is the event ID.
- -D-L-S-E-A — value parameter. In this case, the minus sign (-)disables all masks for the INPUT CONTACT #1 event.

13.0 TOUCH SCREEN DISPLAY

The Liebert STS2/PDU can be configured with a Color Graphical LCD touch screen display that allows you to quickly check the status of the unit and identify problems.

A touch screen LCD is available through the front of the Liebert STS2/PDU. This screen provides a graphical (Mimic) display of the switch's operation, plus system information including system parameters, alarms and faults.

The LCD provides a color, back-lit touch screen as a user interface. In addition to the Mimic and the system parameters, the screen provides a series of menus to allow you to configure the Liebert STS2/PDU, including the control of the preferred source, auto/manual retransfer selection, alarm notification and other system setpoints. The touch screen also provides buttons to reset alarms and turn off audible alarms, such as a horn.

13.1 Display Overview

The Liebert STS2/PDU Color Graphical Display provides three areas of information, plus buttons and a series of menu choices.

The Color Graphical Display contains the following features:

- **Mimic** — a graphical diagram of the status of the unit.
- **Event controls** — allow you to reset alarms and turn off audible alarms.
- **Event display** — displays any active alarm or fault condition, in real-time.
- **Menus** — provide choices and configuration settings in dialog boxes or information in the display panel.
- **Display panel** — provides additional information, depending on the menu choice that was last selected. This information includes event help text and startup and bypass procedures.

Figure 61 Liebert STS2/PDU Touch Screen Display

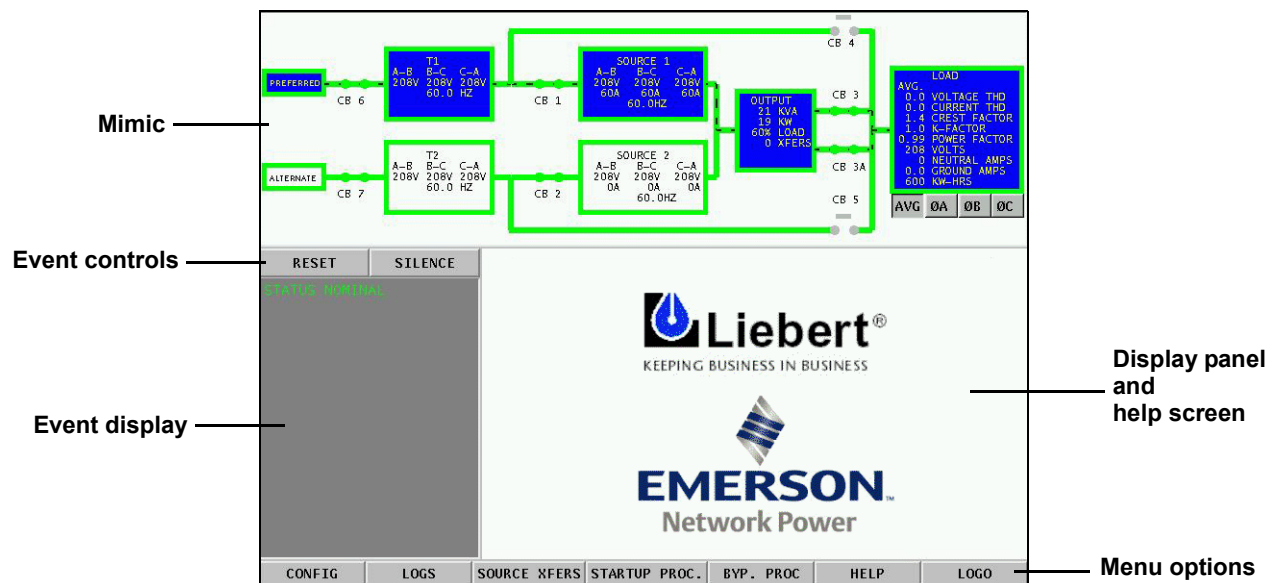

13.2 Menu Overview

The touch screen menu provides access to configuration settings and more device information.

The CONFIG (Configuration) and LOGS menus provide multiple choices through pop-up menus.

The SOURCE XFER menu selection allows you to select the preferred source. The other menu choices provide information in the display panel. The menu choices are discussed later in this manual.

All programmable functions are preset at the factory to default settings. These settings enable the unit to be brought up without the need to enter all selectable parameters. The menus allow the settings to be customized.

Figure 62 Menus

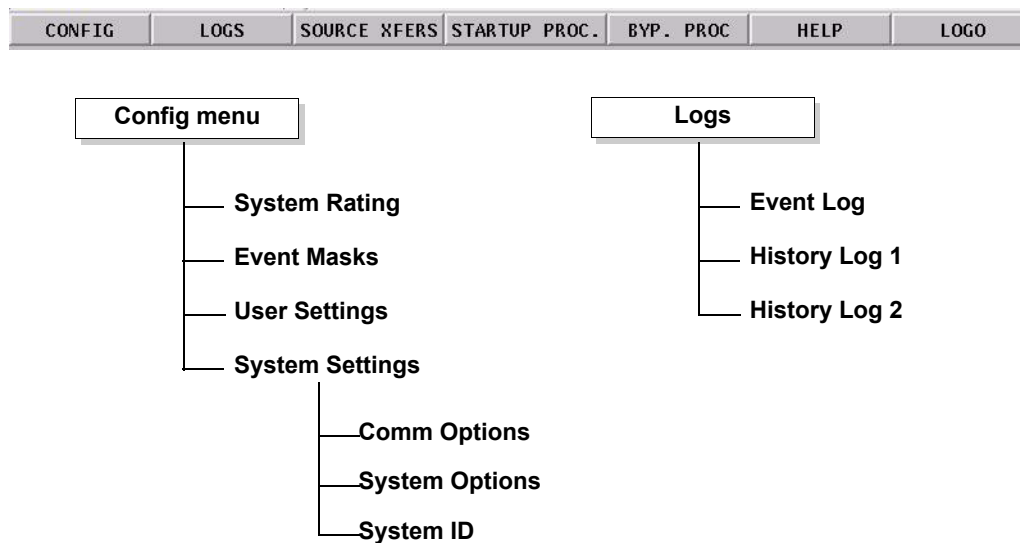

NOTE

Some menu choices display a keyboard or keypad on the touch screen. Enter data on the touch screen.

Click OK to save the data that you have entered.

Use the back arrow button (<-) to delete unwanted characters. This button functions like a backspace key on a keyboard.

Figure 63 Keyboard and keypad displays

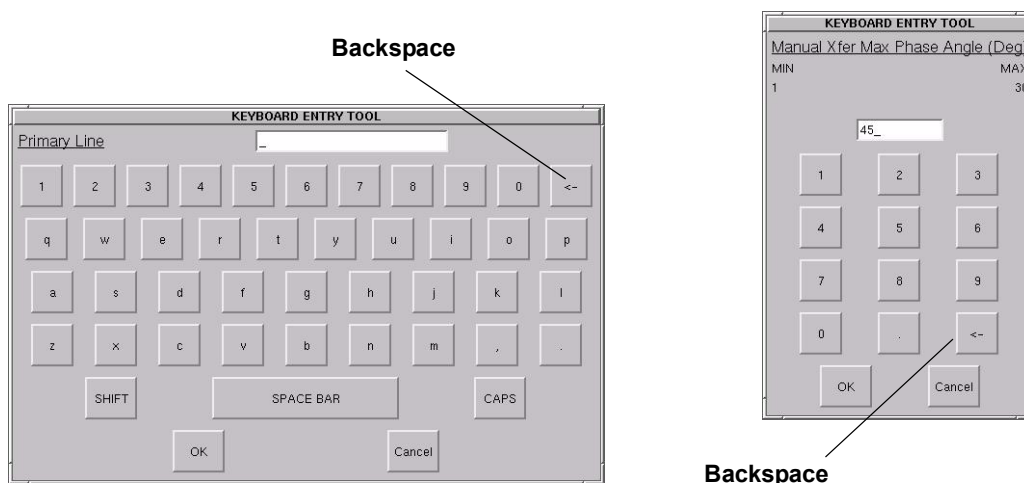

13.2.1 Security

Because the Liebert STS2/PDU Color Graphical Display provides access to various configuration and monitoring choices, a password or key lockout switch may be used to protect access to certain changes, including:

- Change configuration settings
- Clear logs
- Make a source transfer
- Reset an alarm

Without entering the password or enabling changes with the key lockout switch, you still can:

- View the display, including the mimic, status and event help
- View logs
- View the startup and bypass procedures
- Use the SILENCE button to turn off the audible alarm

Using the Optional Key Lockout Switch

An optional key lockout switch for the Liebert STS2/PDU enables or disables the ability to make changes on the Liebert STS2/PDU. The key lockout switch is located on the front of the unit next to the display; it is behind the front door but can be operated without opening the front door. See **Figures 20** through **22** for location of the key lockout switch.

- To disable the changes, turn the key to the top of the switch, toward the closed padlock.
- To enable changes turn the key to the horizontal position, toward the open padlock.

Figure 64 Key lockout switch

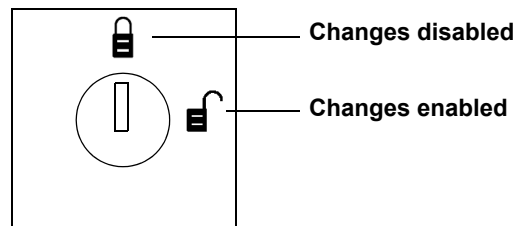

Using the Password

If the unit is not equipped with a keylock, a password is required when you attempt to:

- Save changes in the CONFIG menu choices.
- Transfer sources.
- Reset active alarms.
- Clear logs.

When a password is requested, a keyboard is displayed on the touch screen. After you enter the password, select OK.

The password is case-sensitive. Password access times out after ten (10) minutes and must be re-entered to save changes. The time-out period cannot be changed.

To set or reset the password:

1. Select SYSTEM SETTINGS from the CONFIG menu.
2. Select SYSTEM ID from the SYSTEM SETTINGS menu.
3. Click PASSWORD. A keyboard is displayed.
4. Enter a password. The password must be four (4) alpha-numeric characters and is case sensitive.
5. Click OK.

13.3 Mimic Display

The Mimic display provides a color diagram of the operation of the Liebert STS2/PDU. This display imitates the power flow through the Liebert STS2/PDU and indicates source status, breaker status, switch status, source voltage and current readings, output power measurements and active alarm messages. See **Figure 61**.

13.4 Event Controls

The STS 2 detects events when certain thresholds are passed or certain problems occur. The alarm controls allow you to acknowledge the existence of these events.

- **RESET** — All latched events whose conditions have cleared are removed from the Event Display. Faults and alarms that remain active or are not recoverable are not affected when this button is selected. This button is also used to perform manual I-Peak resets and manual retransfers.
- **SILENCE** — turns off the audible alarm (horn or beeper) without resetting the triggering event. This setting does not permanently turn off the horn. The alarm sounds again when the next event with an audible alarm setting is triggered.

Active events are shown in the Event Display, whereas cleared events can be reviewed via the Event Log.

13.5 Event Display

The Event Display lists the condition of the Liebert STS2/PDU in real-time. Both nominal system parameters and alarm messages are displayed in the Event Display. You can touch any message in the Event Display to display more information in the Display Panel to the left. The selected status is displayed in bold type.

13.6 Menu Bar

As previously mentioned, the menu bar provides both configuration choices and information. The choices under the Config and Log menus access additional dialog boxes, while the other menu choices only show information in the display panel.

13.7 Configuration Menu

When you select the CONFIG (Configuration) menu choice, a pop-up menu is displayed with four choices.

- **SystemRatings**— used to configure frequency, voltage and currents settings for the Liebert STS2/PDU.
 - **Event Mask** — allows you to configure system's response for events.
 - **User Settings** — allows you to configure operations for the Liebert STS2/PDU.
 - **System Settings** — accesses another pop-up menu to configure communication and system choices and the system ID.

Each of these choices accesses a separate dialog box.

System Ratings

The System Ratings menu is used to set the nominal line frequency, nominal voltage and nominal current at which the system operates when it is installed. These settings are configured when the system is initialized at the factory or under maintenance and should not be changed by the user.

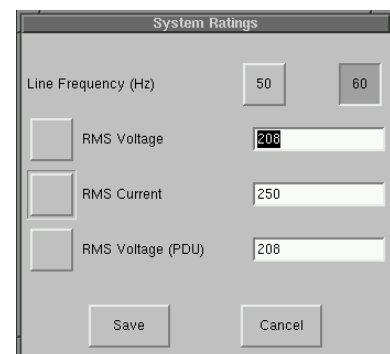

Event Masks

The Liebert STS2/PDU gathers, processes and reports faults and alarms, collectively referred to below as events. The Event Mask dialog box allows you to set the system's response for specific alarms and faults that are generated. See **11.0 - Alarms and Faults** for more information on events and **11.1 - Event Mask** for the definitions of the Event Mask types.

To set the event masks:

1. Access the Event Mask dialog box:
 - a. Select CONFIG.
 - b. Select EVENT MASK from the pop-up menu.
The Event Mask dialog box is displayed. See **Figure 65**.
2. Select the mask settings for each fault and alarm.
 - a. Select YES to enable the setting,
OR
 - b. Select NO to disable the setting.
3. Select SAVE to keep the settings.

Figure 65 Event Mask dialog box

The screenshot shows a dialog box titled "Event Masks". It contains a table with columns for "Alarm / Fault Name", "Latch", "Dial Out", "Event Log", and "Audible". The table lists five faults under the heading "FAULTS":

Alarm / Fault Name	Latch	Dial Out	Event Log	Audible
FAULTS				
CB1 SHUNT TRIP FAIL	NO	YES	NO	YES
CB2 SHUNT TRIP FAIL	NO	YES	YES	YES
CONTACTOR NEUT FAIL	NO	YES	YES	YES
CONTROL MODULE FAIL	NO	YES	YES	YES
EQUIPMENT FAN FAIL	NO	YES	YES	YES

At the bottom of the dialog box, there are two buttons: "Save" and "Cancel".

User Settings

The User Settings choice allows you to adjust the user-accessible switch settings. Access is limited to qualified personnel via system security.

To access the User Settings dialog box:

1. Select CONFIG.
2. Select USER SETTINGS from the pop-up menu.

The User Settings dialog box is displayed. See **Figure 66**. The top six buttons access a series of secondary dialog boxes to configure the various settings.

Figure 66 User settings dialog box

Source Setpoints

The Source 1/2 Setpoints allows you to configure trigger points for each input source (1 or 2) for the Liebert STS2/PDU via a keypad dialog or HI/LO dialog box. The source numbers do not designate the source as the preferred or alternate source. The numbers simply identify the input source. See **10.2 - Manual Transfer / Preferred Source Selection** to set the preferred source.

The Setpoints are based on values in relation to the nominal voltage required for the Liebert STS2/PDU. UV refers to under voltage, meaning the amount of voltage below the nominal voltage. OV refers to over voltage or the amount of voltage over the nominal voltage.

- Fast UV Setting (%) — if the voltage drops below this set percentage of the nominal voltage, the Liebert STS2/PDU transfers from the current source to the opposite source.
- Slow UV Setting (%) — if the voltage remains this set percentage below the nominal voltage for the period of the slow detection delay, the Liebert STS2/PDU transfers from the current source to the opposite source.
- Slow UV detection delay — the number of cycles that the source must remain below the Slow UV Setting before the Liebert STS2/PDU transfers.
- OV Setting (%) — if the voltage exceeds this set percentage of the nominal voltage for the period of the OV detection delay, the Liebert STS2/PDU transfers from the current source to the opposite source.
- OV Detection Delay — the number of cycles that the source must remain above the OV Setting before the Liebert STS2/PDU transfers sources.
- I-PK Xfer Lockout — if current from the source exceeds this threshold, the Liebert STS2/PDU disables source transfers and has to be reset either manually or automatically. The type of reset is configured under the User Settings.

To configure the setpoints for each source:

1. Select SOURCE 1/2 SETPOINTS from the User Settings dialog box. The Source 1/2 Setpoints dialog is displayed.

Figure 67 Source setpoints

2. Select 1 to configure the settings for Source 1.
3. Configure the settings using the keypad or dialog box that is displayed when you touch a button.

Table 16 Setpoint parameters

Button	Range	Default	Comments
Fast UV Setting (%)	-10 to -30% of Nominal voltage rating	-20%	Set in increments of 1%.
Slow UV Setting (%)	-5 to -20%	-10%	Set in increments of 1%.
Slow UV detection delay	1-60 cycles	5 cycles	Units: Line Cycle
OV Setting (%)	+5% to +20%	+10%	Set in increments of 1%.
OV Detection Delay	1-255 cycles	3 cycles	Units: 1/4 Line Cycle
I-PK Xfer Lockout	0 – 3.0 multiplied by the unit current rating.	1.5 Times Unit Current Rating	I-peak xfer lockout detection point. Units: Amps RMS. Select the HI or LO buttons to configure your setting.

4. Select 2 for Source 2.
5. Configure the settings, as described in step 3.
6. Select SAVE to keep the settings for both sources. The Setpoints dialog is closed and the User Settings dialog is displayed.
7. Select MANUAL MAX XFER PHASE ANGLE. A keypad is displayed.

This setting configures the maximum allowed phase difference between the sources and applies to all manual transfers as well as any auto retransfer.

 - a. Configure this setting with a range of +/- 1-30 degrees. The default setting is +/-15 degrees and the resolution is 1 deg.
 - b. Select OK to save the setting. The setting is now displayed in the adjacent field in the User Settings dialog box.

8. Select FREQUENCY TRIP POINT. A keypad is displayed.
This choice verifies that the source is running at the proper frequency. This choice sets the frequency deviation in the frequency that triggers the frequency trip point alarm. The frequency deviation setting is the allowable frequency variation from nominal (60 or 50 Hz) before activating the frequency deviation alarm. The frequency setting applies to both input sources.
 - a. Configure this setting with a range of 0.1 – 3.0 Hz. The default setting is 3 and the resolution is 0.1.
 - b. Select OK to save the setting.
9. Select RETRANSFER DELAY. A keypad is displayed.
With the secondary source being used, this setting sets the length of time the switch waits until attempting to transfer back to the preferred source.
 - a. Configure this setting with a range of 1 to 60 seconds. The default setting is three (3) seconds and the resolution is 1 second.
 - b. Select OK to save the setting. The setting is now displayed in the adjacent field in the User Settings dialog box.
10. Select AUDIO LEVEL. A dialog box is displayed with HI and LO settings.
This choice sets the loudness of the horn or beeper that is sounded for audible alarms.
 - a. Configure this setting with a range of 1–10 (ten). The default setting is 5. The settings have an increment of 1 (one).
 - b. Select OK to save the setting. The setting is now displayed in the adjacent field in the User Settings dialog box.
You can select TEST to briefly sound the alarm to judge its volume.
11. Select DISPLAY BRIGHTNESS. A dialog box is displayed with HI and LO settings.
This choice sets the brightness for the touch screen.
 - a. Configure the Contrast and Brightness settings with a range of 1 – 10 (ten).
 - b. Select OK to save the settings.
12. Set the AUTO REXFER ENABLE choice. The auto retransfer enable setting determines whether the switch automatically returns the preferred source after that source is restored.
 - Select YES to enable the automatic transfer.
 - Select NO to disable the automatic transfer. The setting requires transfers be done manually.
13. Set the AUTO RESTART ENABLE choice. This setting determines whether the Liebert STS2/PDU can be started automatically when power is restored after it has been lost.
Select YES to enable the automatic restart.
Select NO to disable the automatic restart. This settings requires a manual restart of the Liebert STS2/PDU.
To manually restart the Liebert STS2/PDU:
 - a. Select SOURCE TRANSFER from the MENU bar. The SELECT PREFERRED SOURCE window is displayed.
 - b. Select Source 1 or Source 2 as your preferred source. The unit will restart.
14. Select a setting for the I-PEAK RESET.
 - Select AUTO to configure the Liebert STS2/PDU to automatically reset when a fault clears and the voltage and current are normal.
 - Select MAN to require a manual reset of the Liebert STS2/PDU when fault clears and the voltage and current are normal.
 - The default setting is Manual.



CAUTION

Risk of equipment damage and personal injury.

Use of Auto Restart is site-specific. Do not enable auto restart unless the infrastructure is designed for unattended operation and there is no chance of equipment or personnel harm by automatic re-energizing of the system.

Consult with your Liebert site engineer as to whether Auto restart should be enabled.

PDU Setpoints

The PDU Setpoints option allows you to configure the following parameters for the PDU, shown in **Figure 68**.

- Load Voltage THD (%)
- Neutral Current (% of nom)
- Ground Current (A)
- Load Bus Overcurrent (% of nom)

Figure 68 PDU setpoints

Table 17 shows the range of valid values, default values and resolution for each parameter.

Table 17 PDU setpoints

Button	Range	Default	Resolution
Load Voltage THD (%)	3.0% to 99.9%	15.0%	0.1
Neutral Current (% of nom)	10% to 200%	95%	1
Ground Current (A)	1.0A to 50.0A	5.0A	0.1
Load Bus Overcurrent (% of nom)	50% to 100%	100%	—

System Settings

The System Settings choice under the Config menu displays another pop-up menu with three choices:

- Comm Options
- System Options
- System ID

To access the System Settings menu:

1. Select CONFIG from the menu bar.
2. Select SYSTEM SETTINGS from the Config menu.

Comm Options

The Comm Options dialog box allows you to configure the communications settings for the Liebert STS2/PDU.

- Select COMM OPTIONS from the System Settings Menu.
- The Comm Options dialog box is displayed. See **Figure 69**.
- An option can be enabled by selecting YES.
- An option can be disabled by selecting NO.
- An option can be configured by selecting the adjacent option button to display a separate configuration dialog box.

The instructions for configuring the communications options are provided in this section.

Figure 69 Comm options dialog box

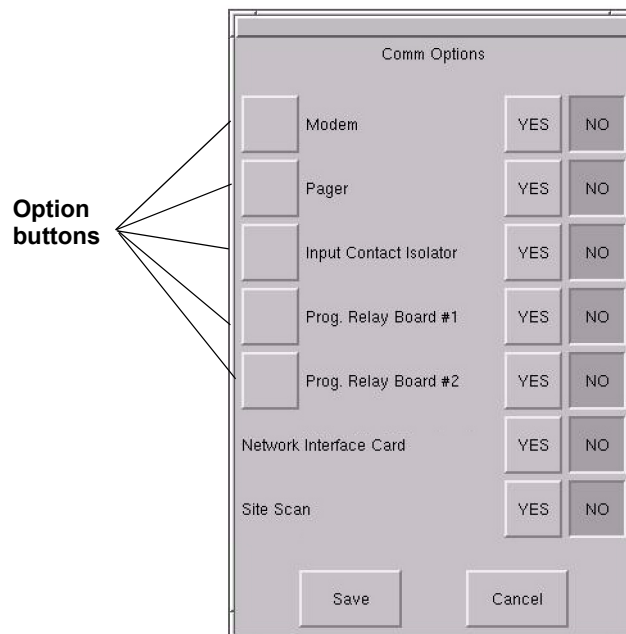

Configuring the Modem

The Modem dialog box allows configuring an external modem connected to the Liebert STS2/PDU.

The dialog box contains a series of choices that access either a keypad or a secondary dialog to configure settings. Auto dial can also be configured for the modem to be triggered by events, as set up in the Event Mask choices.

Designated major alarms activate the auto dial modem sequence. Automatic dial attempts are made to the first number three times, at 30 seconds between attempts. If connection is not established in that time period, the system automatically rolls over to the second number. Auto dial attempts are made again three more times at 30 seconds between attempts. The process is repeated until a successful connection is made. Upon successful connection, the system transmits a present status data, including all active alarms messages. After transmission, the modem automatically hangs up and returns to the auto-answer mode.

To configure the modem:

1. Select MODEM from the Comm Options menu. The Modem dialog box is displayed.

Figure 70 Modem dialog box

2. Select the type of modem that the Liebert STS2/PDU will be using:
 - Select INT internal modem not available.
 - Select EXT if the Liebert STS2/PDU will be communicating via an external modem.
3. Select the PRIMARY LINE choice to enter the primary telephone number for the modem to dial when an alarm is triggered.
4. Enter the number in the keypad dialog box.
5. Select OK to save the telephone number. The number is displayed in the field adjacent to the Primary Line choice.
6. Select the SECONDARY LINE choice to enter the secondary telephone number for the modem to dial when an alarm is triggered.
7. Enter the number in the keypad dialog box.
8. Select OK to save the telephone number. The number is displayed in the field adjacent to the Secondary Line choice.
9. Select INIT. STRING to configure the initialization string. This string configures the parameters of the modem. Check your modem's documentation for this setting.
10. Select BAUD RATE to display a dialog with the baud rate choices:
 - For an external modem, select from 2400 bps, 9600 bps or 19200 bps.

11. Configure the MODEM HEALTH CHECK. The Health Check verifies that the modem is working properly. This setting allows you to enable the check and set when it is run.
 - a. Select the button to display the Modem Health Check dialog box, from which you can access further dialogs to set the time and days that the check is run.
 - b. Select SAVE to keep the settings.
The Health Check dialog box is closed and the Modem dialog box is again active.
 - c. Select YES in the Modem dialog box to activate the Modem Health Check. If you select NO, the Modem Health Check is not run.
12. Configure AUTO DIAL IN. Auto Dial In allows a user to dial into the Liebert STS2/PDU through the modem to check status and access the system via a hyperterminal connection.
 - a. Select YES to activate the dial in feature.
 - b. Select NO to deactivate the dial in feature.
13. Configure AUTO DIAL OUT. Auto Dial Out allows the Liebert STS2/PDU to automatically dial out to a system to notify a user of an event or status.
 - a. Select YES to activate the dial out feature.
 - b. Select NO to deactivate the dial out feature.
14. Select SAVE to keep the modem configuration settings.
15. Select YES in the Comm Options dialog box to activate the settings. You are returned to the Comm Options dialog box.

Configuring the Input Contact Isolator Settings

The Input Contact Isolator (ICI) is an optional, eight-channel input board for up to eight external user alarm or message inputs to be routed to the Liebert STS2/PDU's alarm network.

The contact is set to either be normally open or normally closed. When a contact closes or opens, an event is triggered. See **6.2 - Input Contact Isolator Board** for more information on the ICI.

The Input Contact Isolator options are configured through the Input Contact Isolator dialog box, which is accessed from the Comm Options dialog box. The Input Contact Isolator dialog box contains eight choices to match the eight channel input board. You can label each button to identify the event associated with the contact. When the dialog box is accessed, each button flashes to display the Input Contact Isolator number and the user entered label. This label also appears in the Display Panel when an event related to an Input Isolator Connector is triggered.

The Input Contact Isolator dialog box allows you to:

- Label the input contact assignments for your setup.
- Set the delay for an external event triggering an alarm.
- Review the isolator contact assignments, once the labels are entered.

The delay allows you to set the number of seconds which a condition needs to persist to trigger an alarm.

These input alarms can also be configured to activate a programmable relay output, which is discussed in **Configuring the Programmable Relay Board Settings on page 108**.

To configure the Input Contact Isolator relays:

1. Select INPUT CONTACT ISOLATOR from the Comm Options menu.
The Input Contact Isolator dialog box is displayed.

Figure 71 Input Contact Isolator dialog box

Input Contact	Delay
INPUT CONTACT #1	0.0
INPUT CONTACT #2	0.0
INPUT CONTACT #3	0.0
INPUT CONTACT #4	0.0
INPUT CONTACT #5	0.0
INPUT CONTACT #6	0.0
INPUT CONTACT #7	0.0
INPUT CONTACT #8	0.0

Buttons: Save, Cancel

2. Select INPUT CONTACT 1.
A keyboard is displayed to allow you to enter the name of the alarm.
3. Enter the name of the alarm set for that input. For example, a fan problem could be indicated by naming the button FAN.
4. Select OK on the keyboard to keep your label.
5. Select DELAY.
A keypad is displayed prompting you for a delay time, in seconds, for a condition to exist before the alarm is triggered.
6. Enter the delay value. The range for the values are from 0 (zero) to 99.9 seconds.
7. Select OK on the keypad to keep your setting.
The value you entered is displayed in the field adjacent to the corresponding input contact.
8. Repeat **Steps 2 to 7** for each input contact.
9. Select SAVE after you have configured all input contacts.
Be sure to select Save even if you have accessed this dialog only to change a setting.
10. Enter the settings in **Table 31 - Input contact isolator settings record**.
This information is not saved if control power is removed.
11. Select OK in the Comm Options dialog box to activate the settings.

Configuring the Programmable Relay Board Settings

The Liebert STS2/PDU can contain up to two programmable relay boards (PRB) that can trigger an external device when an event occurs in the Liebert STS2/PDU. For example, if Source 1 fails, an external light flashes.

See **6.1 - Programmable Relay Board** for more information on the PRBs.

The programmable relay board dialog box with two options: STANDARD SET and USER DEFINED SET. The STANDARD SET are the factory-configured settings.

The STANDARD SET for the programmable relay board settings are:

Table 18 Standard settings for programmable relays

Relay	Setting	Definition
1	SOURCE 1 FAIL	Source 1 failure
2	SOURCE 2 FAIL	Source 2 failure
3	BYPASS CB4 CLOSED	Switch (CB4) is closed; Source 1 is bypassed.
4	BYPASS CB5 CLOSED	Switch (CB5) is closed; Source 2 is bypassed.
5	TRANSFER INHIBIT	A transfer between Source 1 and Source 2 is being restrained.
6	OUT OF SYNC	The phase difference between sources 1 and 2 exceeds the allowable threshold for transfer.
7	EQUIP OVER TEMP	The ambient temperature of the ProductName exceeds the recommended threshold for operation.
8	Blank	No setting

The USER DEFINED SET allows you to assign faults and alarms to each contact on the relay boards.

Utilizing the USER DEFINED SET, you can also select Input Contact Isolators to associate with a programmable relay.

In addition individual events, three other assignment choices are available:

- **SELECT ALL** sends a summary event to the selected relay whenever any event occurs. If this setting is selected for a relay, no other event needs to be assigned for that relay.
- **ON SOURCE 1** or **ON SOURCE 2** can be assigned to a relay to send a notification when that source is being used by the load.

Once configured, the Liebert STS2/PDU continuously checks the status of the items defined for each contact and updates the state of the relay.

To configure your programmable relay boards for user defined settings:

1. Select PROG. RELAY BOARD # x from the Comm Options dialog box, where x is the corresponding board number.
The Prog. Relay Board dialog box is displayed.

Figure 72 Programmable relay board dialog box

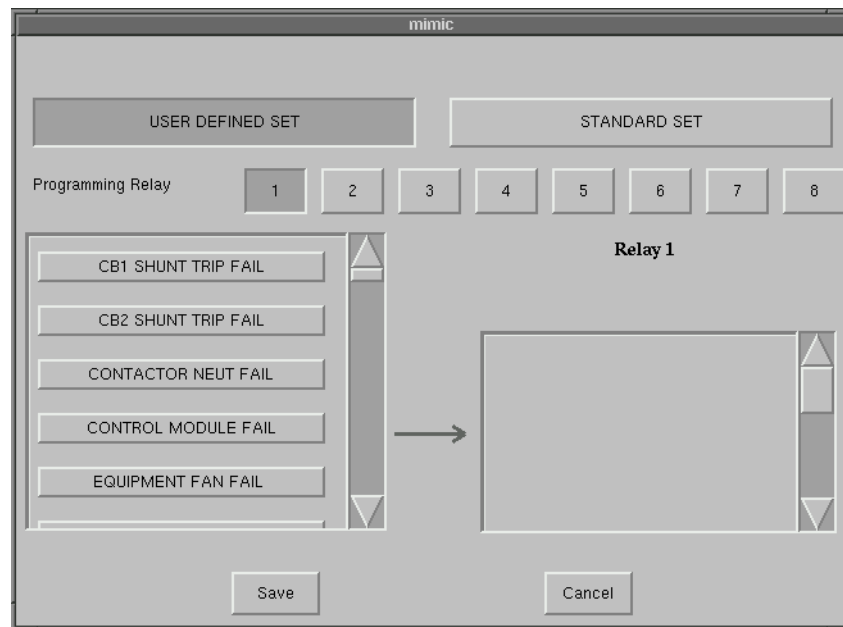

2. Select your configuration settings.
 - Select STANDARD SET to use the settings configured at the factory. See Go to step 4.
 - Select USER DEFINED SET to configure your own settings. Go to step 3.

If you enter a user-defined setting, record the setting in **Table 30**. If for some reason the control board is replaced, it will be necessary to reprogram the Programmable Relay Board with this information.
3. To define your relay board settings:
 - a. Select a Programming Relay.
 - b. Select an event you want associated with the relay. That fault is placed in the Relay column. You can associate up to ten (10) events with one relay. If you do so, you should group the events logically to simplify troubleshooting when an event is triggered.
4. Select SAVE to keep the settings.
5. Select OK for the applicable Programmable Options Board option in the Comm Options dialog box to activate the settings.

Configuring the Liebert IntelliSlot® Web/485 Card With Adapter

A Liebert IntelliSlot Web/485 Card With Adapter (IS-WEB485ADPT) can be installed in the Liebert STS2/PDU to provide Ethernet connectivity via an RJ-45 port.

Ethernet cabling is the responsibility of the customer. Category 5 cabling is required.

See **6.4 - Liebert IntelliSlot® Web/485 Card With Adapter** for more information on the card. See the Liebert IS-WEB485ADPT installation and user guide for configuration instructions for the card.

If the optional Liebert IS-WEB485ADPT is installed in the Liebert STS2/PDU:

- Select YES for the Liebert IntelliSlot Web/485 Card With Adapter option in the Comm Options dialog box to activate the card.

Liebert SiteScan Configuration

An RS-422 port on the optional Comms Board provides communications with Liebert's SiteScan. Liebert SiteScan is Liebert's system-monitoring software that allows you to utilize a PC to monitor the Liebert STS2/PDU's status and check alarms. See **6.3 - Comms Board** for more information on this board.

If the Liebert STS2/PDU will be connected to Liebert SiteScan:

- Select YES for the Liebert SiteScan choice in the Comm Options dialog box to activate the card.

Saving Your Communications Configurations

To save you communications configuration settings:

1. When you have completed the Comm Options configurations, ensure you have selected YES for all the settings that you want activated.
2. Select SAVE to keep the settings.

Whenever you make modifications to the any of the Comm Options, select SAVE to keep the changes.

System Options

Most system options are configured at the factory. However, you may need to set two of the choices after the unit is installed: Wye Output Transformer and Remote Source Selection.

- Select SYSTEM OPTIONS from the System Settings Menu.
The System Options dialog box is displayed.
- An option is enabled by selecting YES.
- An option is disabled by selecting NO.

Figure 73 System options

Option	YES	NO
Dual Output Breaker	<input checked="" type="button"/>	<input type="button"/>
<input checked="" type="checkbox"/> PDU	<input checked="" type="button"/>	<input type="button"/>
4 Pole Transfer Switch	<input checked="" type="button"/>	<input type="button"/>
Shunt Trip	<input checked="" type="button"/>	<input type="button"/>
Wye Output Transformer	<input checked="" type="button"/>	<input type="button"/>
Remote Source Select	<input checked="" type="button"/>	<input type="button"/>

Save Cancel

Dual Output Breaker

This selection is set at the factory. The choice is set to YES to enable both output breakers (CB3 and CB3A) when two are installed in the unit. If only one output breaker (CB3) is installed, the setting is set to NO.

PDU

This selection is set at the factory to YES, which allows the LCD to draw the Mimic accordingly and display PDU metering and alarm information.

Select the PDU button in the System Options window (see **Figure 73**). This opens the PDU Options window, shown below in **Figure 74**.

Figure 74 PDU options button

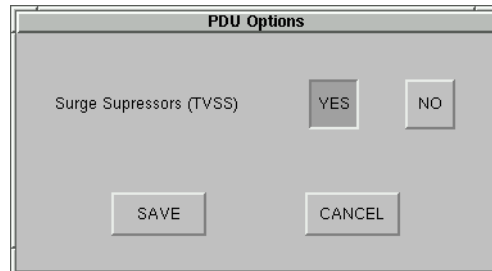

The PDU Options window allows you to specify whether you have the surge suppression option.

- If the TVSS option is installed, this selection is set at the factory to YES. To disable surge suppression, click NO.
- Click SAVE.

4 Pole Transfer Switch

This selection is set at the factory to indicate whether the system is a 3 pole or 4 pole unit. The 4 pole design is not available at this time.

Shunt Trip

This selection is set at the factory.

Wye Output Transformer

The Wye Output Transformer controls the firing of the SCRs on startup, which minimizes the inrush into PDU transformers. Output breakers and PDU input breakers have to be closed when you start up the system. Based on whether the input side of the PDU transformer is configured as a Wye or Delta changes the firing sequence of the SCRs.

If the Liebert STS2/PDU is connected to a PDU configured as a Wye:

- Select YES for the Wye Output Transformer choice in the System Options dialog box.

Remote Source Select

If your system is configured with the optional Remote Source Selection, it must be enabled from the System Options menu. See **4.4 - Remote Source Selection Wiring** for more information.

If the system is utilizing Remote Source Selection:

- Select YES for the Remote Source Select choice in the System Options dialog box to activate the option.

System ID

Most of the settings for System ID are set by Liebert either at the factory or when the unit is installed.

The system is identified and tracked with these numbers: Order No., System Tag No., System ID No. and Model No.

Language, Time and Date are synchronized with the location of the unit.

The only configurable field is the Password. See **Using the Password on page 97** for more information on configuring and using the password.

13.7.1 Logs

Two types of logs are kept by the Liebert STS2/PDU: Event Log and History Log.

Event Log

The Event Log tracks the alarms and faults of the Liebert STS2/PDU.

See **11.0 - Alarms and Faults** for more information on these events and see **11.2.1 - Event Log** for more information on the Event Log and definitions of the fields displayed in the Event Log screen.

Figure 75 Event log

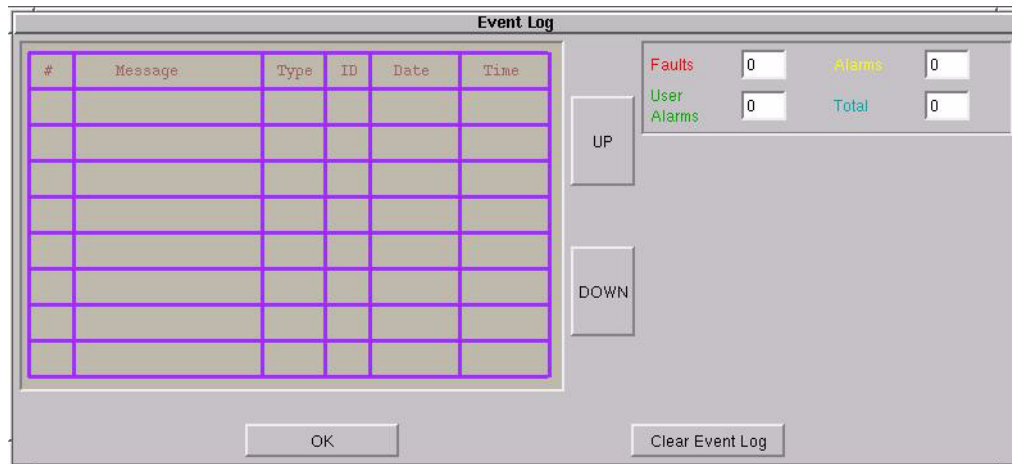

To use the Event Log:

1. Select LOGS from the menu bar to open the Logs menu.
2. Select EVENT LOG from the menu.
3. Use the UP and DOWN buttons to scroll through the event list.
4. Select OK to close the Event Log. The data remains in the log.

History Log

Two History Logs are available to track major alarms. If so configured, an alarm freezes the history buffer. When the History Status buffer is frozen, a History Log is created that can be accessed from the HISTORY LOG x choices in the LOGS menu.

See **11.2.2 - History Log** for more information on the History Logs and definitions of the fields displayed in the History Log screen.

Figure 76 History log

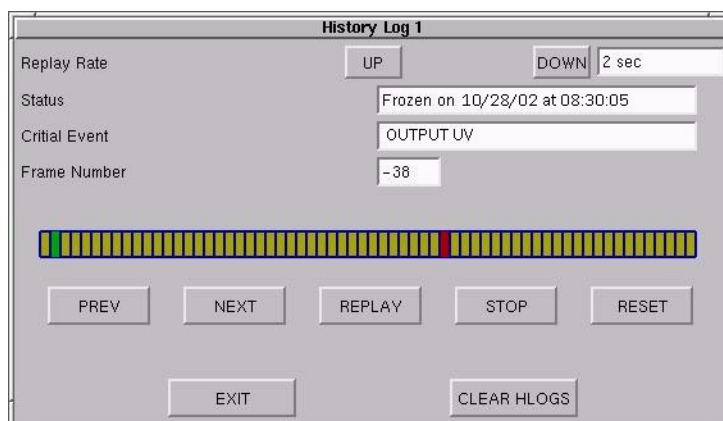

To use the History Log:

1. Select LOGS from the menu bar to open the Logs menu.
2. Select either HISTORY LOG 1 or HISTORY LOG 2 from the menu.
3. Select the appropriate buttons to replay the log:
 - Select PREV to go to the previous frame in the sequence.
 - Select NEXT to go to the next frame in the sequence.
 - Move the green cursor to the location from which you would like to play the sequence of events.
 - Select REPLAY to play the frames automatically from the point of the cursor.
 - Select STOP to halt the replay.
 - Select RESET to return to the first frame in the log.
4. Select EXIT to close the History Log. The data remains in the log.
 - Use CLEAR HLOGS to remove the data from both history logs.

**NOTE**

Event and History Logs are protected by security. The password or a disabled key lockout is required on such equipped units to clear these logs.

13.7.2 Source Transfers

The Source Transfer choice (SOURCE XFERS) allows you to manually select a preferred source.

To switch the primary source, refer to **10.2 - Manual Transfer / Preferred Source Selection**.

13.7.3 Startup Procedure

You can access instructions for starting the Liebert STS2/PDU from the menu bar.

- From the menu bar, select STARTUP PROC.

These instructions are also provided on **10.1 - Normal System Turn-On**.

13.7.4 Bypass Procedure

You can access instructions for bypassing the Liebert STS2/PDU from the menu bar.

- From the menu bar, select BYP. PROC.

The instructions are provided in the display panel.

Bypass procedures are also discussed in **10.4 - Maintenance Bypass**.

13.7.5 Help

You can select an event in the Event Display to display more information about that event in the Display Panel. This same help is also available in **15.0 - Event Message Help Text**.

13.7.6 Logo

The Logo menu choice shows the Liebert and Emerson logo in the Display panel.

13.8 Cleaning the LCD Touch Screen

If the touch screen requires cleaning, use a pre-moistened towelette designed for cleaning CRTs or dampen a soft, non-abrasive cloth with a very mild cleaning solution.

Do not spray the cleaner directly onto the touch screen, as drips may run down into the screen and damage the equipment.

Close all menus and dialog boxes before cleaning the touch screen.

14.0 SPECIFICATIONS

14.1 System Configuration

The Liebert STS2/PDU can be set in several different configurations, according to the model and location. The configuration is set at the factory and does not need to be changed by the customer.

14.1.1 Frequency

The Liebert STS2/PDU accepts input frequencies of 50 Hz or 60 Hz, depending on the model ordered. The frequency shall be within +/- 0.5 Hz of the nominal frequency.

14.1.2 Input Voltage

The Liebert STS2/PDU models are available to handle various voltages.

The input voltage must be three phase AC (3 wire-plus-ground).

The voltage shall be within +/- 10% of the nominal voltage.

The following table provides nominal voltages, listed according to frequency.

Table 19 Input voltage

60 Hz (L-L)	50 Hz (L-L)
208V	208V
380V	380V
400V	400V
415V	415V
480V	-
600V	-

14.1.3 Output Voltage

The output voltage shall be three phase AC (4 wire-plus-ground).

Table 20 Output voltage

60 Hz (L-L/L-N)	50 Hz (L-L/L-N)
208/120V	208/120V
380/220V	380/220V
400/230V	400/230V
415/240V	415/240V

14.1.4 System Current Ratings

These ratings are based upon continuous switch current rating. All units are 100% continuous current rated. Some ratings are not available in certain voltages.

Table 21 System current ratings

Current
250A
400A
600A
800A

14.1.5 Grounding

Refer to 4.2 - **System Grounding** for specifications and instructions regarding grounding.

14.1.6 Electrical Requirements

Table 22 Electrical requirements

Item	Requirement
Maximum Continuous Current	250, 400, 600, 800 amps
Load Power Factor Range	0.75 to 1.0, leading or lagging
Load Crest Factor	Up to 3.5
Source Voltage Distortion	Up to 10% THD with notches and ringing transients
Overload Capability	125% for 30 minutes 250A-400A
	125% for 10 minutes 600A-800A
	150% for 2 minutes
	500% for 0.25 sec

Table 23 Unit short circuit withstand capability

Unit Voltage	Unit Amps	Withstand Capability
208-240V	250A	125kA
	400-600A	100kA
	800A	100kA
380-480V	250A	100kA
	400-600A	100kA
	800A	65kA
600V	250A	50kA
	400-600A	25kA
	800A	25kA

14.1.7 Surge Suppression

The static transfer switch is equipped with transient voltage surge suppression on each input for surge suppression. The surge suppression is capable of protecting the static transfer switch from operating outside of tolerances due to surges as defined by IEC 1000-4-5 (1.2/50uS surge, 2kV CM and 1kV DM) as required under EN 50091-2. Optional surge suppression modules (TVSS) are available for each input of the Liebert STS2/PDU for surge protection of the transformers.

14.1.8 Response Time

A dual level fast/slow transfer threshold is used for under voltage detection to allow the Liebert STS2/PDU to be compatible with UPSs and generators. The voltage thresholds and the slow transfer delay time is user-adjustable. The fast transfer delay time is less than 4 ms.

The over voltage detection uses a single threshold, with programmable level and delay time. See **User Settings on page 100** for instructions on configuring these settings.

14.1.9 Environmental Requirements

See **3.0 - Locating the Liebert STS2/PDU** for details concerning environmental requirements for the Liebert STS2/PDU.

14.2 System Components

All Liebert STS2/PDU models provide two isolation transformers connected to a solid-state, three-pole dual-position static transfer switch within one enclosure, with the ability to transfer between two input sources to a single output.

All Liebert STS2/PDUs are configured with an LCD Color Graphical Interface touch screen display for monitoring and configuring the unit.

14.2.1 Frame and Enclosure

The complete Liebert STS2/PDU is housed in a freestanding enclosure. The cabinet is a NEMA type 1 enclosure. The cabinet is structurally designed to handle lifting from the base. The frame is designed to accommodate floor stands.

Table 24 Frame sizes

Rating	Width x Depth x Height in. (mm)
250A	60 x 32 x 77 (152 x 81 x 196)*
400 – 600A	73 x 49 x 77 (186 x 125 x 196)
800A	96 x 49 x 77 (244 x 125 x 196)

* Width is 76.8 in (195 cm) with output distribution cabinet

The distributed floor weight for Liebert STS2/PDU is less than 260 lb./sq. ft. (118 kg/m²).

The required service access is front and one side of the unit, 250A without output cabinet is front access only. Side access depends on which side the output cabinet is mounted, can be left or right.

The Liebert STS2/PDU can be tipped 15° in any direction without falling over.

14.2.2 Caster and Leveling - 250A only

The 250A unit frame includes heavy-duty swivel casters for ease of installation, plus permanent leveling feet for final installation.

14.2.3 Cooling

The Liebert STS2/PDU 250A units utilize convection air cooling for the enclosure with forced air cooling of the heat sinks.

The 400-800A units are fan cooled using low-velocity fans to minimize audible noise. All fans are redundant so that a single fan failure cannot cause temperatures to increase beyond acceptable limits.

Air intake is through screened protective openings in the front of the unit. A standard furnace filter is installed behind the openings.

By opening the front door, the filter can be changed easily without exposing personnel to high voltage. The size of the filter is 1 in. x 25 in. x 25 in. (2.54 cm x 63.5 cm x 63.5 cm).

The air exhaust is through the top of the unit.

14.2.4 Access

The Liebert STS2/PDU is designed so repairs and maintenance can be done from the front, side or top of the unit. All components that may need repair or replacement during routine field maintenance are safely accessed with the units in bypass without removing power from the unit. These components include:

- All electronic PCB assemblies
- Power supply assemblies
- All control fuses
- All circuit breaker plug-in modules
- Fans
- SCRs

All power connections are designed to maintain proper connection torque over the lifetime of the unit without any maintenance. The integrity of the connections can be checked via infrared scanning safely from the front or top of the unit.

All other components including transformers, power cables and connections, circuit breaker bases, etc., are replaceable from the front, rear or top of the unit, but this requires all power to be removed from the unit for safety. Although routine re-torquing of the power connections is not required, if maintenance of these connections is needed, complete removal of power is required from the unit for safety reasons.



WARNING

Risk of electric shock. Can cause injury or death.

Lethal voltages exist inside the unit during normal operation. Only properly trained and qualified service personnel should perform maintenance on the Liebert STS2/PDU.

The unit is supplied by more than one power source. The unit contains hazardous voltages if any of the input sources is on, even when the unit is in bypass. To isolate the unit, turn off and lock out all input power sources.

Verify that all input power sources are de-energized and locked out before making connections inside unit.

14.2.5 Circuit Breakers

The Liebert STS2/PDU is equipped with two input plug-in circuit breakers and five or six (if CB3A is used) molded-case, plug-in, non-automatic circuit breakers. The breakers are UL listed for use up to 600VAC and CE marked. The plug-in feature of the breaker includes an interlock, which prevents the breaker from being unplugged without being in the OFF (open) position.

Mechanical interlocks are provided on the breakers to prevent improper maintenance bypassing of the solid-state switch. A bypass breaker cannot be closed unless the solid-state switch is connected to the same input source and only one bypass breaker can be closed at a time. All breakers are equipped with N.O. and N.C. auxiliary switches for monitoring of the breaker positions. The two solid-state static switch input breakers are equipped with 48 VDC shunt trips to allow for control by the Liebert STS2/PDU logic. See **Tables 8 through 10**.

14.2.6 Cable Entrance

Removable conduit termination plates are provided in the top and bottom of the Liebert STS2/PDU for termination of the two source input conduits or raceways and/or the output conduits or raceways. On units with inline panelboards, output conduit or raceways are bottom exit only.

14.2.7 Doors

A removable key lock hinged front door provides access to the circuit breakers.

14.2.8 Color Graphical Display

The display is located in the front of the unit. Front panel display is an LCD touch screen display for monitoring and configuring the unit. See **Figure 56** for a drawing of the touch screen display.

14.2.9 RS-232 Port

The unit is equipped with an RS-232 port for connecting a terminal or PC. See **Figure 54** for the port's location. See **12.1 - Using the RS-232 Port** for instructions on using a PC terminal with the unit.

14.2.10 Terminal Port Connections

The system has an asynchronous serial port configured as Data Terminal Equipment for terminal access only (half duplex). The CPU services the terminal port with no handshaking. The serial port conforms to RS-232 levels with a data format of 9600 Baud, 1 start bit, 8 data bits and no parity bits. The serial port is 1000VDC isolated (non-SELV) and ESD protected to 15kV air discharge.

The connector is a 6 Pin MTA plug with connections shown below.

Table 25 MTA plug pinout

Pin	Signal Name	Function / Comments
1	ISO_GND	Isolated service terminal ground
2	ISO_TXD	Isolated service terminal transmit output
3	ISO_RXD	Isolated service terminal receive input
4	NC	No Connection
5	NC	No Connection
6	NC	No Connection

A DB9 male connector is added and connected parallel to the 6 position header. It is configured as DTE.

Table 26 DB9 pinout

Pin	Signal Name	Function / Comments
1	NC	No Connection
2	ISO_RXD	Isolated service terminal transmit output
3	ISO_TXD	Isolated service terminal receive input
4	NC	No Connection
5	ISO_GND	Isolated service terminal ground
6	NC	No Connection
7	NC	No Connection
8	NC	No Connection
9	NC	No Connection

14.2.11 RS-232 Interface Parameters

The service terminal interface parameters are the following settings and cannot be changed.

Table 27 RS-232 settings

Parameter	Setting
Interface	RS-232 Using EIA Voltage Levels
Baud Rate	9600
Parity	None
Number of Data Bits	8
Number of Stop Bits	1
Hardware Flow Control	Off
Terminator	<CR> <LF>
Handshaking	Not supported
Structure	Full duplex
Local Echo	Off

14.2.12 Maintenance Bypass

The Liebert STS2/PDU is configured to allow the unit's electronics to be bypassed to either input source for maintenance without interruption of power to the load.

The Liebert STS2/PDU is furnished with key-interlocked maintenance bypass breakers to configure the bypass.

Liebert STS2/PDU units have all electronics isolated from the input, output and bypass connections to allow safe servicing of any components without access to hazardous voltages when the unit is in maintenance bypass.

See **10.4 - Maintenance Bypass** for instructions.

14.2.13 Fuseless Design

All Liebert STS2/PDU units are fuseless.

14.2.14 Options

The following options are available for the Liebert STS2/PDU:

- Panelboards
- Subfeed Breakers
- K-Factor Transformers
- Surge Suppression System (TVSS)
- Redundant Static Switch Output Breaker
- Programmable Relay Board
- Comms Board w/Liebert SiteScan and Modem Interface
- Input Contact Isolator Board
- Liebert IntelliSlot Web/485 Card With Adapter
- Remote Source Selection
- Key Lockout Switch
- Export Crating

See **6.0 - Options** for more information.

15.0 EVENT MESSAGE HELP TEXT

Key

ALL CAPS = Event message displayed in the Event Display panel in the lower left corner of the LCD.

Indented text = Help text shown in the Display Panel in the lower right corner of LCD.

BOLD = Commands that are sent through the RS-232 port.

S1 SCR SHORT

Source 1 SCR Short

One or more of the SCRs for Source 1 has shorted. Transferring between sources has been inhibited.

Contact technical support; in the United States, call 1-800-LIEBERT (1-800-543-2378). Outside the 48 contiguous United States contact Liebert Services, if available in your area. For international areas not covered by Liebert Services, the Liebert authorized distributor can provide technical support.

Press SILENCE on the touch screen to turn off the audible alarm, if so configured. If you are accessing the Liebert STS2/PDU system from a terminal, type **SH** and press RETURN on your keyboard to turn off the audible alarm.

This event and the system status surrounding it have been written to a History Log if the History Logs were not already full. This event was also written to the Event Log, if so configured.

The alarm has triggered a message to be sent to the modem, if so configured.

S2 SCR SHORT

Source 2 SCR Short.

One or more of the SCRs for Source 2 has shorted. Transferring between sources has been inhibited.

Press SILENCE on the touch screen to turn off the audible alarm, if so configured. If you are accessing the Liebert STS2/PDU system from a terminal, type **SH** and press RETURN on your keyboard to turn off the audible alarm.

This event and the system status surrounding it have been written to a History Log if the History Logs were not already full. This event was also written to the Event Log, if so configured.

The alarm has triggered a message to be sent to the modem, if so configured.

S1 SCR OPEN

Source 1 SCR Open.

One or more SCRs on Source 1 is open. Transferring between sources has been inhibited.

Contact technical support; in the United States, call 1-800-LIEBERT (1-800-543-2378). Outside the 48 contiguous United States contact Liebert Services, if available in your area. For international areas not covered by Liebert Services, the Liebert authorized distributor can provide technical support.

Liebert STS2/PDU output has been transferred to Source 2.

Press SILENCE on the touch screen to turn off the audible alarm, if so configured. If you are accessing the Liebert STS2/PDU system from a terminal, type **SH** and press RETURN on your keyboard to turn off the audible alarm.

This event and the system status surrounding it have been written to a History Log if the History Logs were not already full. This event was also written to the Event Log, if so configured.

The alarm has triggered a message to be sent to the modem, if so configured.

S2 SCR OPEN

Source 2 SCR Open.

One or more SCRs on Source 2 is open. Transferring between sources has been inhibited.

Liebert STS2/PDU output has been transferred to Source 1.

Contact technical support; in the United States, call 1-800-LIEBERT (1-800-543-2378). Outside the 48 contiguous United States contact Liebert Services, if available in your area. For international areas not covered by Liebert Services, the Liebert authorized distributor can provide technical support.

Press SILENCE on the touch screen to turn off the audible alarm, if so configured. If you are accessing the Liebert STS2/PDU system from a terminal, type **SH** and press RETURN on your keyboard to turn off the audible alarm.

This event and the system status surrounding it have been written to a History Log if the History Logs were not already full. This event was also written to the Event Log, if so configured.

The alarm has triggered a message to be sent to the modem, if so configured.

PRIMARY FAN FAIL

Primary Fan Failure

One of the primary cooling fans for the Liebert STS2/PDU has failed. The alternate fans are now running. The alternate fans are not monitored.

Contact technical support; in the United States, call 1-800-LIEBERT (1-800-543-2378). Outside the 48 contiguous United States contact Liebert Services, if available in your area. For international areas not covered by Liebert Services, the Liebert authorized distributor can provide technical support.

Press SILENCE on the touch screen to turn off the audible alarm, if so configured. If you are accessing the Liebert STS2/PDU system from a terminal, type **SH** and press RETURN on your keyboard to turn off the audible alarm.

This event was written to the Event Log, if so configured.

The alarm has triggered a message to be sent to the modem, if so configured.

CONTROL MODULE FAIL

Control logic module has failed.

One of the control modules on the control board has failed.

Contact technical support; in the United States, call 1-800-LIEBERT (1-800-543-2378). Outside the 48 contiguous United States contact Liebert Services, if available in your area. For international areas not covered by Liebert Services, the Liebert authorized distributor can provide technical support.

Press SILENCE on the touch screen to turn off the audible alarm, if so configured. If you are accessing the Liebert STS2/PDU system from a terminal, type **SH** and press RETURN on your keyboard to turn off the audible alarm.

This event was written to the Event Log, if so configured.

The alarm has triggered a message to be sent to the modem, if so configured.

If configured to be a latching alarm, press RESET on the display. If you are accessing the unit from a terminal, type **CA** and press RETURN on your keyboard.

PWR SPLY DC A FAIL

Power Supply DC Bus A Failed

The primary power supply is no longer providing DC power to the control board and the touch screen.

Contact technical support; in the United States, call 1-800-LIEBERT (1-800-543-2378). Outside the 48 contiguous United States contact Liebert Services, if available in your area. For international areas not covered by Liebert Services, the Liebert authorized distributor can provide technical support.

Press SILENCE on the touch screen to turn off the audible alarm, if so configured. If you are accessing the Liebert STS2/PDU system from a terminal, type **SH** and press RETURN on your keyboard to turn off the audible alarm.

This event was written to the Event Log, if so configured.

The alarm has triggered a message to be sent to the modem, if so configured.

If configured to be a latching alarm, press RESET on the display. If you are accessing the unit from a terminal, type **CA** and press RETURN on your keyboard.

PWR SPLY DC B FAIL

Power Supply DC Bus B Failed

The secondary power supply is no longer providing DC power to the control board and CAN options.

Contact technical support; in the United States, call 1-800-LIEBERT (1-800-543-2378). Outside the 48 contiguous United States contact Liebert Services, if available in your area. For international areas not covered by Liebert Services, the Liebert authorized distributor can provide technical support.

Press SILENCE on the touch screen to turn off the audible alarm, if so configured. If you are accessing the Liebert STS2/PDU system from a terminal, type **SH** and press RETURN on your keyboard to turn off the audible alarm.

This event was written to the Event Log, if so configured.

The alarm has triggered a message to be sent to the modem, if so configured.

If configured to be a latching alarm, press RESET on the display. If you are accessing the unit from a terminal, type **CA** and press RETURN on your keyboard.

PWR SPLY S1 AC FAIL

Power Supply Source 1 AC Failed

The AC input power to the power supplies from Source 1 has failed. The power supplies are now operating on AC power from Source 2. The AC input from Source 1 is still good.

Contact technical support; in the United States, call 1-800-LIEBERT (1-800-543-2378). Outside the 48 contiguous United States contact Liebert Services, if available in your area. For international areas not covered by Liebert Services, the Liebert authorized distributor can provide technical support.

Press SILENCE on the touch screen to turn off the audible alarm, if so configured. If you are accessing the Liebert STS2/PDU system from a terminal, type **SH** and press RETURN on your keyboard to turn off the audible alarm.

This event was written to the Event Log, if so configured.

The alarm has triggered a message to be sent to the modem, if so configured.

If configured to be a latching alarm, press RESET on the display. If you are accessing the unit from a terminal, type **CA** and press RETURN on your keyboard.

PWR SPLY S2 AC FAIL

Power Supply Source 2 AC Failed

The AC input power to the power supplies from Source 2 has failed.

The power supplies are now operating on AC power from Source 1. The AC input from Source 2 is still good.

Contact technical support; in the United States, call 1-800-LIEBERT (1-800-543-2378). Outside the 48 contiguous United States contact Liebert Services, if available in your area. For international areas not covered by Liebert Services, the Liebert authorized distributor can provide technical support.

Press SILENCE on the touch screen to turn off the audible alarm, if so configured. If you are accessing the Liebert STS2/PDU system from a terminal, type **SH** and press RETURN on your keyboard to turn off the audible alarm.

This event was written to the Event Log, if so configured.

The alarm has triggered a message to be sent to the modem, if so configured.

If configured to be a latching alarm, press RESET on the display. If you are accessing the unit from a terminal, type **CA** and press RETURN on your keyboard.

PWR SPLY LOGIC FAIL

Power Supply Module Failed

The power supply logic module contained in the primary power supply has failed.

Contact technical support; in the United States, call 1-800-LIEBERT (1-800-543-2378). Outside the 48 contiguous United States contact Liebert Services, if available in your area. For international areas not covered by Liebert Services, the Liebert authorized distributor can provide technical support.

Press SILENCE on the touch screen to turn off the audible alarm, if so configured. If you are accessing the Liebert STS2/PDU system from a terminal, type **SH** and press RETURN on your keyboard to turn off the audible alarm.

This event was written to the Event Log, is so configured.

The alarm has triggered a message to be sent to the modem, if so configured.

If configured to be a latching alarm, press RESET on the display. If you are accessing the unit from a terminal, type **CA** and press RETURN on your keyboard.

OUT VOLT SENSE FAIL

Output Voltage Sense Module Failed

The module contained on the snubber monitoring the output voltage has failed.

Press SILENCE on the touch screen to turn off the audible alarm, if so configured. If you are accessing the Liebert STS2/PDU system from a terminal, type **SH** and press RETURN on your keyboard to turn off the audible alarm.

Contact technical support; in the United States, call 1-800-LIEBERT (1-800-543-2378). Outside the 48 contiguous United States contact Liebert Services, if available in your area. For international areas not covered by Liebert Services, the Liebert authorized distributor can provide technical support.

This event was written to the Event Log, if so configured.

The alarm has triggered a message to be sent to the modem, if so configured.

If configured to be a latching alarm, press RESET on the display. If you are accessing the unit from a terminal, type **CA** and press RETURN on your keyboard.

S1 VOLT SENSE FAIL

Source 1 Voltage Sense Module Failed

The module contained on the snubber monitoring the input voltage from Source 1 has failed.

Press SILENCE on the touch screen to turn off the audible alarm, if so configured. If you are accessing the Liebert STS2/PDU system from a terminal, type **SH** and press RETURN on your keyboard to turn off the audible alarm.

Contact technical support; in the United States, call 1-800-LIEBERT (1-800-543-2378). Outside the 48 contiguous United States contact Liebert Services, if available in your area. For international areas not covered by Liebert Services, the Liebert authorized distributor can provide technical support.

This event was written to the Event Log, if so configured.

The alarm has triggered a message to be sent to the modem, if so configured.

If configured to be a latching alarm, press RESET on the display. If you are accessing the unit from a terminal, type **CA** and press RETURN on your keyboard.

S2 VOLT SENSE FAIL

Source 2 Voltage Sense Module Failed

The module contained on the snubber monitoring the input voltage from Source 2 has failed.

Press SILENCE on the touch screen to turn off the audible alarm, if so configured. If you are accessing the Liebert STS2/PDU system from a terminal, type **SH** and press RETURN on your keyboard to turn off the audible alarm.

Contact technical support; in the United States, call 1-800-LIEBERT (1-800-543-2378). Outside the 48 contiguous United States contact Liebert Services, if available in your area. For international areas not covered by Liebert Services, the Liebert authorized distributor can provide technical support.

This event was written to the Event Log, if so configured.

The alarm has triggered a message to be sent to the modem, if so configured.

If configured to be a latching alarm, press RESET on the display. If you are accessing the Liebert STS2/PDU system from a terminal, type **CA** and press RETURN on your keyboard.

S1 SCR SENSE FAIL

Source 1 SCR Sense Module Failed

The module contained on the snubber monitoring the SCRs for Source 1 has failed.

Press SILENCE on the touch screen to turn off the audible alarm, if so configured. If you are accessing the Liebert STS2/PDU system from a terminal, type **SH** and press RETURN on your keyboard to turn off the audible alarm.

Contact technical support; in the United States, call 1-800-LIEBERT (1-800-543-2378). Outside the 48 contiguous United States contact Liebert Services, if available in your area. For international areas not covered by Liebert Services, the Liebert authorized distributor can provide technical support.

This event was written to the Event Log, if so configured.

The alarm has triggered a message to be sent to the modem, if so configured.

If configured to be a latching alarm, press RESET on the display. If you are accessing the Liebert STS2/PDU system from a terminal, type **CA** and press RETURN on your keyboard.

S2 SCR SENSE FAIL

Source 2 SCR Sense Module Failed

The module contained on the snubber monitoring the SCRs for Source 2 has failed.

Press SILENCE on the touch screen to turn off the audible alarm, if so configured. If you are accessing the Liebert STS2/PDU system from a terminal, type **SH** and press RETURN on your keyboard to turn off the audible alarm.

Contact technical support; in the United States, call 1-800-LIEBERT (1-800-543-2378). Outside the 48 contiguous United States contact Liebert Services, if available in your area. For international areas not covered by Liebert Services, the Liebert authorized distributor can provide technical support.

This event was written to the Event Log, if so configured.

The alarm has triggered a message to be sent to the modem, if so configured.

If configured to be a latching alarm, press RESET on the display. If you are accessing the Liebert STS2/PDU system from a terminal, type **CA** and press RETURN on your keyboard.

S1 CURR SENSE FAIL

Source 1 Current Sense Failure

The module monitoring the current from Source 1 has failed. This module is contained on the left side gate driver board.

Press SILENCE on the touch screen to turn off the audible alarm, if so configured. If you are accessing the Liebert STS2/PDU system from a terminal, type **SH** and press RETURN on your keyboard to turn off the audible alarm.

This event was written to the Events Log, is so configured.

The alarm has triggered a message to be sent to the modem, if so configured.

If configured to be a latching alarm, press RESET on the display. If you are accessing the Liebert STS2/PDU system from a terminal, type **CA** and press RETURN on your keyboard.

S2 CURR SENSE FAIL

Source 2 Current Sense Failure

The module monitoring the current from Source 2 has failed. This module is contained on the right side gate driver board.

Press SILENCE on the touch screen to turn off the audible alarm, if so configured. If you are accessing the Liebert STS2/PDU system from a terminal, type **SH** and press RETURN on your keyboard to turn off the audible alarm.

This event was written to the Events Log, is so configured.

The alarm has triggered a message to be sent to the modem, if so configured.

If configured to be a latching alarm, press RESET on the display. If you are accessing the Liebert STS2/PDU system from a terminal, type **CA** and press RETURN on your keyboard.

S1 GATE DRIVE FAIL

Source 1 Gate Drive Failure

The gate drive module for an SCR for Source 1 has failed. This module is contained on the right side gate driver board.

Press SILENCE on the touch screen to turn off the audible alarm, if so configured. If you are accessing the Liebert STS2/PDU system from a terminal, type **SH** and press RETURN on your keyboard to turn off the audible alarm.

Contact technical support; in the United States, call 1-800-LIEBERT (1-800-543-2378). Outside the 48 contiguous United States contact Liebert Services, if available in your area. For international areas not covered by Liebert Services, the Liebert authorized distributor can provide technical support.

This event was written to the Event Log, if so configured.

The alarm has triggered a message to be sent to the modem, if so configured.

If configured to be a latching alarm, press RESET on the display. If you are accessing the Liebert STS2/PDU system from a terminal, type **CA** and press RETURN on your keyboard.

S2 GATE DRIVE FAIL

Source 1 Gate Drive Failure

The gate drive module for an SCR for Source 2 has failed. This module is contained on the left side gate driver board.

Press SILENCE on the touch screen to turn off the audible alarm, if so configured. If you are accessing the Liebert STS2/PDU system from a terminal, type **SH** and press RETURN on your keyboard to turn off the audible alarm.

Contact technical support; in the United States, call 1-800-LIEBERT (1-800-543-2378). Outside the 48 contiguous United States contact Liebert Services, if available in your area. For international areas not covered by Liebert Services, the Liebert authorized distributor can provide technical support.

This event was written to the Event Log, if so configured.

The alarm has triggered a message to be sent to the modem, if so configured.

If configured to be a latching alarm, press RESET on the display. If you are accessing the unit from a terminal, type **CA** and press RETURN on your keyboard.

INTERNAL COMM FAIL

Internal CAN Communications Failed

Communications have failed in the CAN bus between the control board and the touch screen control.

Press SILENCE on the touch screen to turn off the audible alarm, if so configured. If you are accessing the Liebert STS2/PDU system from a terminal, type **SH** and press RETURN on your keyboard to turn off the audible alarm.

Contact technical support; in the United States, call 1-800-LIEBERT (1-800-543-2378). Outside the 48 contiguous United States contact Liebert Services, if available in your area. For international areas not covered by Liebert Services, the Liebert authorized distributor can provide technical support.

This event was written to the Event Log, if so configured.

The alarm has triggered a message to be sent to the modem, if so configured.

If configured to be a latching alarm, press RESET on the display. If you are accessing the unit from a terminal, type **CA** and press RETURN on your keyboard.

CB1 SHUNT TRIP FAIL

Circuit Breaker 1 Shunt Trip Failure

Circuit Breaker 1 failed to trip open when the control issued a command for the circuit breaker to trip.

Press SILENCE on the touch screen to turn off the audible alarm, if so configured. If you are accessing the Liebert STS2/PDU system from a terminal, type **SH** and press RETURN on your keyboard to turn off the audible alarm.

Contact technical support; in the United States, call 1-800-LIEBERT (1-800-543-2378). Outside the 48 contiguous United States contact Liebert Services, if available in your area. For international areas not covered by Liebert Services, the Liebert authorized distributor can provide technical support.

This event was written to the Event Log, if so configured.

The alarm has triggered a message to be sent to the modem, if so configured.

If configured to be a latching alarm, press RESET on the display. If you are accessing the unit from a terminal, type **CA** and press RETURN on your keyboard.

CB2 SHUNT TRIP FAIL

Circuit Breaker 2 Shunt Trip Failure

Circuit Breaker 2 failed to trip open when the control issued a command for the circuit breaker to trip.

Press SILENCE on the touch screen to turn off the audible alarm, if so configured. If you are accessing the Liebert STS2/PDU system from a terminal, type **SH** and press RETURN on your keyboard to turn off the audible alarm.

Contact technical support; in the United States, call 1-800-LIEBERT (1-800-543-2378). Outside the 48 contiguous United States contact Liebert Services, if available in your area. For international areas not covered by Liebert Services, the Liebert authorized distributor can provide technical support.

This event was written to the Event Log, if so configured.

The alarm has triggered a message to be sent to the modem, if so configured.

If configured to be a latching alarm, press RESET on the display. If you are accessing the unit from a terminal, type **CA** and press RETURN on your keyboard.

EQUIPMENT FAN FAILURE

Equipment Fan Failure

One of the equipment fans has failed.

Contact technical support; in the United States, call 1-800-LIEBERT (1-800-543-2378). Outside the 48 contiguous United States contact Liebert Services, if available in your area. For international areas not covered by Liebert Services, the Liebert authorized distributor can provide technical support.

Press SILENCE on the touch screen to turn off the audible alarm, if so configured. If you are accessing the Liebert STS2/PDU system from a terminal, type **SH** and press RETURN on your keyboard to turn off the audible alarm.

This event and the system status surrounding it have been written to a History Log if the History Logs were not already full. This event was also written to the Event Log, if so configured.

The alarm has triggered a message to be sent to the modem, if so configured.

INPUT 1 SURGE FAILURE

Input 1 Surge Failure

Source 1 input surge suppression module has failed.

Contact technical support; in the United States, call 1-800-LIEBERT (1-800-543-2378). Outside the 48 contiguous United States contact Liebert Services, if available in your area. For international areas not covered by Liebert Services, the Liebert authorized distributor can provide technical support.

Press SILENCE on the touch screen to turn off the audible alarm, if so configured. If you are accessing the Liebert STS2/PDU system from a terminal, type **SH** and press RETURN on your keyboard to turn off the audible alarm.

This event and the system status surrounding it have been written to a History Log if the History Logs were not already full. This event was also written to the Event Log, if so configured.

The alarm has triggered a message to be sent to the modem, if so configured.

INPUT 2 SURGE FAILURE

Input 2 Surge Failure

Source 2 input surge suppression module has failed.

Contact technical support; in the United States, call 1-800-LIEBERT (1-800-543-2378). Outside the 48 contiguous United States contact Liebert Services, if available in your area. For international areas not covered by Liebert Services, the Liebert authorized distributor can provide technical support.

Press SILENCE on the touch screen to turn off the audible alarm, if so configured. If you are accessing the Liebert STS2/PDU system from a terminal, type **SH** and press RETURN on your keyboard to turn off the audible alarm.

This event and the system status surrounding it have been written to a History Log if the History Logs were not already full. This event was also written to the Event Log, if so configured.

The alarm has triggered a message to be sent to the modem, if so configured.

HEAT SINK OVERTEMP

Heat Sink Over Temperature

The system heat sink temperature has exceeded the design limits.

Take immediate steps to cool the unit. Remove obstructions from the air inlet in the front of the unit. Remove and replace the air filter behind the front door. A standard furnace filter can be used.

Press SILENCE on the touch screen to turn off the audible alarm, if so configured. If you are accessing the Liebert STS2/PDU system from a terminal, type **SH** and press RETURN on your keyboard to turn off the audible alarm.

This event was written to the Event Log, if so configured.

The alarm has triggered a message to be sent to the modem, if so configured.

EQUIPMENT OVERTEMP

Equipment Over Temperature

Cabinet has exceeded the recommended temperature.

Contact technical support; in the United States, call 1-800-LIEBERT (1-800-543-2378). Outside the 48 contiguous United States contact Liebert Services, if available in your area. For international areas not covered by Liebert Services, the Liebert authorized distributor can provide technical support.

Press SILENCE on the touch screen to turn off the audible alarm, if so configured. If you are accessing the Liebert STS2/PDU system from a terminal, type **SH** and press RETURN on your keyboard to turn off the audible alarm.

This event and the system status surrounding it have been written to a History Log if the History Logs were not already full. This event was also written to the Event Log, if so configured.

S1 UV

Source 1 Under Voltage (fast detection).

The input voltage from Source 1 dropped below a set percentage of the nominal voltage, as set in the Fast UV setpoint under the User Settings. An S1 Fail alarm was also issued and source transfer has been inhibited.

The load of the Liebert STS2/PDU has been transferred to Source 2.

Press SILENCE on the touch screen to turn off the audible alarm, if so configured. If you are accessing the Liebert STS2/PDU system from a terminal, type **SH** and press RETURN on your keyboard to turn off the audible alarm.

This event was written to the Event Log, if so configured.

The alarm has triggered a message to be sent to the modem, if so configured.

If configured to be a latching alarm, press RESET on the display. If you are accessing the unit from a terminal, type **CA** and press RETURN on your keyboard.

S1 UV (RMS)

Source 1 Under Voltage (slow detection).

The input voltage from Source 1 remained below a set percentage of the nominal voltage for a designated period, as set in the Slow UV Setting and Slow UV Detection Delay setpoints configured under the User Settings. An S1 Fail alarm was also issued and source transfer has been inhibited.

The load of the Liebert STS2/PDU has been transferred to Source 2.

Press SILENCE on the touch screen to turn off the audible alarm, if so configured. If you are accessing the Liebert STS2/PDU system from a terminal, type **SH** and press RETURN on your keyboard to turn off the audible alarm.

The alarm is latched and must be reset after the voltage returns to the nominal voltage. If the Reset option is not configured for AUTO (automatic reset), then the reset action must be done manually. When the voltage is within acceptable parameters, touch the RESET button on the touch screen. If you are accessing the unit from a terminal, type **CA** and press RETURN on your keyboard.

This event was written to the Event Log, if so configured.

The alarm has triggered a message to be sent to the modem, if so configured.

S1 OV

Source 1 Over Voltage.

The input voltage from Source 1 exceeded a set percentage of the nominal voltage, as set in the OV Setting and OV Detection Delay setpoints configured under the User Settings. An S1 Fail alarm was also issued and source transfer has been inhibited.

The load of the Liebert STS2/PDU has been transferred to Source 2.

Press SILENCE on the touch screen to turn off the audible alarm, if so configured. If you are accessing the Liebert STS2/PDU system from a terminal, type **SH** and press RETURN on your keyboard to turn off the audible alarm.

This event was written to the Event Log, if so configured.

The alarm has triggered a message to be sent to the modem, if so configured.

If configured to be a latching alarm, press RESET on the display. If you are accessing the unit from a terminal, type **CA** and press RETURN on your keyboard.

S1 OF/UF

Source 1 Over Frequency/Under Frequency

The frequency for Source 1 is running outside the acceptable operating range, as set in the Frequency Trip Point under User Settings. An S1 Fail alarm was also issued and source transfer has been inhibited.

Press SILENCE on the touch screen to turn off the audible alarm, if so configured. If you are accessing the Liebert STS2/PDU system from a terminal, type **SH** and press RETURN on your keyboard to turn off the audible alarm.

This event was written to the Event Log, if so configured.

The alarm has triggered a message to be sent to the modem, if so configured.

If configured to be a latching alarm, press RESET on the display. If you are accessing the unit from a terminal, type **CA** and press RETURN on your keyboard.

S1 FAIL

Source 1 Failure

Source 1 has failed due to under voltage (UV), over voltage (OV) or from running over or under frequency (OF/UF). This alarm is a companion to S1 UV, S1 UV (RMS), S1 OV and S1 OF/UF.

The load of the Liebert STS2/PDU has been transferred to Source 2.

Press SILENCE on the touch screen to turn off the audible alarm, if so configured. If you are accessing the Liebert STS2/PDU system from a terminal, type **SH** and press RETURN on your keyboard to turn off the audible alarm.

This event has been written to the Event Log, if so configured.

The alarm has triggered a message to be sent to the modem, if so configured.

If configured to be a latching alarm, press RESET on the display. If you are accessing the unit from a terminal, type **CA** and press RETURN on your keyboard.

S2 UV

Source 2 Under Voltage (fast detection).

The input voltage from Source 2 dropped below a set percentage of the nominal voltage, as set in the Fast UV setpoint under the User Settings. An S2 Fail alarm was also issued and source transfer has been inhibited.

The load of the Liebert STS2/PDU has been transferred to Source 1.

Press SILENCE on the touch screen to turn off the audible alarm, if so configured. If you are accessing the Liebert STS2/PDU system from a terminal, type **SH** and press RETURN on your keyboard to turn off the audible alarm.

This event was written to the Event Log, if so configured.

The alarm has triggered a message to be sent to the modem, if so configured.

If configured to be a latching alarm, press RESET on the display. If you are accessing the unit from a terminal, type **CA** and press RETURN on your keyboard.

S2 UV (RMS)

Source 2 Under Voltage (slow detection).

The input voltage from Source 2 remained below a set percentage of the nominal voltage for a designated period, as set in the Slow UV Setting and Slow UV Detection Delay setpoints configured under the User Settings. An S2 Fail alarm was also issued and source transfer has been inhibited.

The load of the Liebert STS2/PDU has been transferred to Source 1.

Press SILENCE on the touch screen to turn off the audible alarm, if so configured. If you are accessing the Liebert STS2/PDU system from a terminal, type **SH** and press RETURN on your keyboard to turn off the audible alarm.

The alarm is latched and must be reset after the voltage returns to the nominal voltage. If the Reset option is not configured for AUTO (automatic reset), then the reset action must be done manually. When the voltage is within acceptable parameters, touch the RESET button on the touch screen. If you are accessing the unit from a terminal, type **CA** and press RETURN on your keyboard.

This event was written to the Event Log, if so configured.

S2 OV

Source 2 Over Voltage.

The input voltage from Source 2 exceeded a set percentage of the nominal voltage, as set in the OV Setting and OV Detection Delay setpoints configured under the User Settings. An S2 Fail alarm was also issued and source transfer has been inhibited.

The load of the Liebert STS2/PDU has been transferred to Source 1.

Press SILENCE on the touch screen to turn off the audible alarm, if so configured. If you are accessing the Liebert STS2/PDU system from a terminal, type **SH** and press RETURN on your keyboard to turn off the audible alarm.

This event was written to the Event Log, if so configured.

The alarm has triggered a message to be sent to the modem, if so configured.

If configured to be a latching alarm, press RESET on the display. If you are accessing the unit from a terminal, type **CA** and press RETURN on your keyboard.

S2 UF/OF

Source 2 Under Frequency/Over Frequency

The frequency for Source 2 is running outside the acceptable operating range, as set in the Frequency Trip Point under User Settings. An S2 Fail alarm was also issued and source transfer has been inhibited.

Press SILENCE on the touch screen to turn off the audible alarm, if so configured. If you are accessing the Liebert STS2/PDU system from a terminal, type **SH** and press RETURN on your keyboard to turn off the audible alarm.

This event was written to the Event Log, if so configured.

The alarm has triggered a message to be sent to the modem, if so configured.

If configured to be a latching alarm, press RESET on the display. If you are accessing the unit from a terminal, type **CA** and press RETURN on your keyboard.

S2 FAIL

Source 2 Failure

Source 2 has failed due to under voltage (UV), over voltage (OV) or running with an over or under frequency (OF/UF).

This alarm is a companion to S2 UV, S2 UV (RMS), S2 OV and S2 OF/UF.

The load of the Liebert STS2/PDU has been transferred to Source 1.

Press SILENCE on the touch screen to turn off the audible alarm, if so configured. If you are accessing the Liebert STS2/PDU system from a terminal, type **SH** and press RETURN on your keyboard to turn off the audible alarm.

This event was written to the Event Log, if so configured.

The alarm has triggered a message to be sent to the modem, if so configured.

If configured to be a latching alarm, press RESET on the display. If you are accessing the unit from a terminal, type **CA** and press RETURN on your keyboard.

S1 OVERCURRENT

Source 1 Overcurrent

Liebert STS2/PDU is running on Source 1 and an overload condition has occurred on one or more phases.

Note: The overload setpoint is a single fixed number—101%. An overload condition is detected when the measured load current is equal to or greater than the setpoint.

Press SILENCE on the touch screen to turn off the audible alarm, if so configured. If you are accessing the Liebert STS2/PDU system from a terminal, type **SH** and press RETURN on your keyboard to turn off the audible alarm.

This event was written to the Event Log, if so configured.

The alarm has triggered a message to be sent to the modem, if so configured.

If configured to be a latching alarm, press RESET on the display. If you are accessing the unit from a terminal, type **CA** and press RETURN on your keyboard.

S2 OVERCURRENT

Source 1 Overcurrent

Liebert STS2/PDU is running on Source 2 and an overload condition has occurred on one or more phases.

Note: The overload setpoint is a single fixed number—101%. An overload condition is detected when the measured load current is equal to or greater than the setpoint.

Press SILENCE on the touch screen to turn off the audible alarm, if so configured. If you are accessing the Liebert STS2/PDU system from a terminal, type **SH** and press RETURN on your keyboard to turn off the audible alarm.

This event was written to the Event Log, if so configured.

The alarm has triggered a message to be sent to the modem, if so configured.

If configured to be a latching alarm, press RESET on the display. If you are accessing the unit from a terminal, type **CA** and press RETURN on your keyboard.

S1 I-PEAK

Current Peak on Source 1

The peak current from Source 1 has exceeded the setpoint as defined in the I-PK Xfer Lockout setting under User Settings.

Transferring to Source 2 has been inhibited.

Press SILENCE on the touch screen to turn off the audible alarm, if so configured. If you are accessing the Liebert STS2/PDU system from a terminal, type **SH** and press RETURN on your keyboard to turn off the audible alarm.

This event and the system status surrounding it have been written to a History Log if the History Logs were not already full. This event was also written to the Event Log, if so configured.

If this alarm is configured to automatically reset under the setpoints for User Settings, the alarm clears itself when the I-Peak condition clears.

If this alarm is set for manual reset mode, the alarm continues to show as active after the current returns to nominal, still inhibiting transfers. You will need to manually reset the alarm. If configured to be a latching alarm, press RESET on the display. If you are accessing the unit from a terminal, type **CA** and press RETURN on your keyboard.

The alarm has triggered a message to be sent to the modem, if so configured.

S2 I-PEAK

Current Peak on Source 2

The peak current from Source 2 has exceeded the setpoint as defined in the I-PK Xfer Lockout setting under User Settings.

Transferring to Source 1 has been inhibited.

Press SILENCE on the touch screen to turn off the audible alarm, if so configured. If you are accessing the Liebert STS2/PDU system from a terminal, type **SH** and press RETURN on your keyboard to turn off the audible alarm.

This event and the system status surrounding it have been written to a History Log if the History Logs were not already full. This event was also written to the Event Log, if so configured.

If this alarm is configured to automatically reset under the setpoints for User Settings, the alarm clears itself when the I-Peak condition clears.

If this alarm is set for manual reset mode, the alarm continues to show as active after the current returns to nominal,

still inhibiting transfers. You will need to manually reset the alarm. If configured to be a latching alarm, press RESET on the display. If you are accessing the unit from a terminal, type **CA** and press RETURN on your keyboard.

The alarm has triggered a message to be sent to the modem, if so configured.

SOURCES OUT OF SYNC

Sources out of synchronization.

The phase difference between Source 1 and Source 2 has exceeded the deviation as set for MANUAL MAX XFER PHASE ANGLE under User Settings.

A manual transfer cannot take place while the sources are not synchronized.

Press SILENCE on the touch screen to turn off the audible alarm, if so configured. If you are accessing the Liebert STS2/PDU system from a terminal, type **SH** and press RETURN on your keyboard to turn off the audible alarm.

The event was written to the Event Log, if so configured.

The alarm has triggered a message to be sent to the modem, if so configured.

If configured to be a latching alarm, press RESET on the display. If you are accessing the unit from a terminal, type **CA** and press RETURN on your keyboard.

LOAD ON ALT SOURCE

Liebert STS2/PDU load on the alternate source.

The Liebert STS2/PDU is running on the alternate power source. Check the Event Log to determine the reason for the transfer from the preferred source.

Another event has caused the system to transfer to the alternate source. The system returns the load to the preferred source either automatically or manually, depending on how the system is configured.

In automatic reset mode, the Liebert STS2/PDU automatically retransfers to the preferred source after the causal condition clears.

In manual reset mode, the system remains on the alternate source after the causal event clears until you select RESET from the touchscreen or enter CA (Clear Alarms) from a service terminal.



NOTE

Pressing the RESET button returns the unit to the preferred source. Ensure that the condition that triggered the switch has been rectified before returning to the preferred source.

Press SILENCE on the touch screen to turn off the audible alarm, if so configured. If you are accessing the Liebert STS2/PDU system from a terminal, type **SH** and press RETURN on your keyboard to turn off the audible alarm.

This event was written to the Event Log, if so configured.

The alarm has triggered a message to be sent to the modem, if so configured.

AUTO REXFER INHIBIT

Automatic Retransfer Inhibited.

The system made five transfers from the preferred source to the alternate source in the last five minutes. As a result, automatic retransfers back to the preferred source is now disabled.

To clear this alarm condition, assign the alternate source as the preferred source.

This alarm also is cleared if the unit transfers to the preferred source due to an alternate source AC volt failure (i.e., an emergency transfer.)

Press SILENCE on the touch screen to turn off the audible alarm, if so configured. If you are accessing the Liebert STS2/PDU system from a terminal, type **SH** and press RETURN on your keyboard to turn off the audible alarm.

The event was written to the Event Log, if so configured.

The alarm has triggered a message to be sent to the modem, if so configured.

If configured to be a latching alarm, press RESET on the display. If you are accessing the unit from a terminal, type **CA** and press RETURN on your keyboard.

CB1 (S1) OPEN

Circuit Breaker 1 (for Source 1) Open

Circuit Breaker 1 is not closed. CB1 is only assigned to Source 1.

Check that the Circuit Breaker 1 switch is in the desired position.

Press SILENCE on the touch screen to turn off the audible alarm, if so configured. If you are accessing the Liebert STS2/PDU system from a terminal, type **SH** and press RETURN on your keyboard to turn off the audible alarm.

This event was written to the Event Log, if so configured.

The alarm has triggered a message to be sent to the modem, if so configured.

If configured to be a latching alarm, press RESET on the display. If you are accessing the unit from a terminal, type **CA** and press RETURN on your keyboard.

CB2 (S2) OPEN

Circuit Breaker 2 (for Source 2) Open

Circuit Breaker 2 is not closed. CB1 is only assigned to Source 2.

Check that the Circuit Breaker 2 switch is in the desired position.

Press SILENCE on the touch screen to turn off the audible alarm, if so configured. If you are accessing the Liebert STS2/PDU system from a terminal, type **SH** and press RETURN on your keyboard to turn off the audible alarm.

This event was written to the Event Log, if so configured.

The alarm has triggered a message to be sent to the modem, if so configured.

If configured to be a latching alarm, press RESET on the display. If you are accessing the unit from a terminal, type **CA** and press RETURN on your keyboard.

CB4 (S1 BYP) CLOSED

Circuit Breaker 4 (Source 1 Bypass Breaker) Closed

Circuit breaker 4 is not open. The input from Source 1 is bypassing the Liebert STS2/PDU.

Press SILENCE on the touch screen to turn off the audible alarm, if so configured. If you are accessing the Liebert STS2/PDU system from a terminal, type **SH** and press RETURN on your keyboard to turn off the audible alarm.

This event was written to the Event Log, if so configured.

The alarm has triggered a message to be sent to the modem, if so configured.

If configured to be a latching alarm, press RESET on the display. If you are accessing the unit from a terminal, type **CA** and press RETURN on your keyboard.

CB5 (S1 BYP) CLOSED

Circuit Breaker 5 (Source 2 Bypass Breaker) Closed

Circuit breaker 5 is not open. The input from Source 2 is bypassing the Liebert STS2/PDU.

Press SILENCE on the touch screen to turn off the audible alarm, if so configured. If you are accessing the Liebert STS2/PDU system from a terminal, type **SH** and press RETURN on your keyboard to turn off the audible alarm.

This event was written to the Event Log, if so configured.

The alarm has triggered a message to be sent to the modem, if so configured.

If configured to be a latching alarm, press RESET on the display. If you are accessing the unit from a terminal, type **CA** and press RETURN on your keyboard.

CB3 (OUTPUT) OPEN

Circuit Breaker 3 (Output breaker) Open

Circuit breaker 3 is not closed. This circuit breaker is assigned to the output load. The power flow to the load cannot flow through the Liebert STS2/PDU.

Press SILENCE on the touch screen to turn off the audible alarm, if so configured. If you are accessing the Liebert STS2/PDU system from a terminal, type **SH** and press RETURN on your keyboard to turn off the audible alarm.

This event was written to the Event Log, if so configured.

The alarm has triggered a message to be sent to the modem, if so configured.

If configured to be a latching alarm, press RESET on the display. If you are accessing the unit from a terminal, type **CA** and press RETURN on your keyboard.

CB3A (OUTPUT) OPEN

Circuit Breaker 3A (Output breaker) is Open (Optional)

Circuit breaker 3A is not closed. This circuit breaker is assigned to the output load. The power flow to the load cannot flow through the Liebert STS2/PDU.

Press SILENCE on the touch screen to turn off the audible alarm, if so configured. If you are accessing the Liebert STS2/PDU system from a terminal, type **SH** and press RETURN on your keyboard to turn off the audible alarm.

This event was written to the Event Log, if so configured.

The alarm has triggered a message to be sent to the modem, if so configured.

If configured to be a latching alarm, press RESET on the display. If you are accessing the unit from a terminal, type **CA** and press RETURN on your keyboard.

S1 PHASE ROT ERROR

Source 1 Phase Rotation Error

A phase rotation error condition exists on Source 1. Check the phase sequence (ABC) of Source 1.

Transferring to Source 1 has been inhibited.

Press SILENCE on the touch screen to turn off the audible alarm, if so configured. If you are accessing the Liebert STS2/PDU system from a terminal, type **SH** and press RETURN on your keyboard to turn off the audible alarm.

This event was written to the Event Log, if so configured.

The alarm has triggered a message to be sent to the modem, if so configured.

If configured to be a latching alarm, press RESET on the display. If you are accessing the unit from a terminal, type **CA** and press RETURN on your keyboard.

S2 PHASE ROT ERROR

Source 2 Phase Rotation Error

A phase rotation error condition exists on Source 2. Check the phase sequence (ABC) of Source 2.

Transferring to Source 1 has been inhibited.

Press SILENCE on the touch screen to turn off the audible alarm, if so configured. If you are accessing the Liebert STS2/PDU system from a terminal, type **SH** and press RETURN on your keyboard to turn off the audible alarm.

This event was written to the Event Log, if so configured.

The alarm has triggered a message to be sent to the modem, if so configured.

If configured to be a latching alarm, press RESET on the display. If you are accessing the unit from a terminal, type **CA** and press RETURN on your keyboard.

TRANSFER INHIBITED

Transfer Inhibited

Uninterrupted transfer between sources is inhibited due to input source failure, sources out of sync, switch failure or the unit is in bypass mode.

Check the Event Log for the event or events that may have caused the alarm.

Press SILENCE on the touch screen to turn off the audible alarm, if so configured. If you are accessing the Liebert STS2/PDU system from a terminal, type **SH** and press RETURN on your keyboard to turn off the audible alarm.

This event was written to the Event Log, if so configured.

The alarm has triggered a message to be sent to the modem, if so configured.

If configured to be a latching alarm, press RESET on the display. If you are accessing the unit from a terminal, type **CA** and press RETURN on your keyboard.

OUTPUT UV

Output Undervoltage

The voltage being supplied to the load has dropped below the acceptable nominal voltage. Check the input voltage from both sources.

This event and the system status surrounding it have been written to a History Log if the History Logs were not already full. This event was also written to the Event Log, if so configured.

Press SILENCE on the touch screen to turn off the audible alarm, if so configured. If you are accessing the Liebert STS2/PDU system from a terminal, type **SH** and press RETURN on your keyboard to turn off the audible alarm.

The alarm has triggered a message to be sent to the modem, if so configured.

If configured to be a latching alarm, press RESET on the display. If you are accessing the unit from a terminal, type **CA** and press RETURN on your keyboard.

HISTORY LOG FROZEN

History Log Frozen

Both History Logs have been written and no more history logs can be written without clearing one of the logs.

Contact technical support; in the United States, call 1-800-LIEBERT (1-800-543-2378). Outside the 48 contiguous United States contact Liebert Services, if available in your area. For international areas not covered by Liebert Services, the Liebert authorized distributor can provide technical support.

Press SILENCE on the touch screen to turn off the audible alarm, if so configured. If you are accessing the Liebert STS2/PDU system from a terminal, type **SH** and press RETURN on your keyboard to turn off the audible alarm.

This event and the system status surrounding it have been written to a History Log if the History Logs were not already full. This event was also written to the Event Log, if so configured.

INPUT 1 OVERVOLTAGE

Input 1 Overvoltage

Source 1 is over voltage.

Contact technical support; in the United States, call 1-800-LIEBERT (1-800-543-2378). Outside the 48 contiguous United States contact Liebert Services, if available in your area. For international areas not covered by Liebert Services, the Liebert authorized distributor can provide technical support.

Press SILENCE on the touch screen to turn off the audible alarm, if so configured. If you are accessing the Liebert STS2/PDU system from a terminal, type **SH** and press RETURN on your keyboard to turn off the audible alarm.

This event and the system status surrounding it have been written to a History Log if the History Logs were not already full. This event was also written to the Event Log, if so configured.

INPUT 1 UNDERVOLTAGE

Input 1 Undervoltage

Source 1 is under voltage.

Contact technical support; in the United States, call 1-800-LIEBERT (1-800-543-2378). Outside the 48 contiguous United States contact Liebert Services, if available in your area. For international areas not covered by Liebert Services, the Liebert authorized distributor can provide technical support.

Press SILENCE on the touch screen to turn off the audible alarm, if so configured. If you are accessing the Liebert STS2/PDU system from a terminal, type **SH** and press RETURN on your keyboard to turn off the audible alarm.

This event and the system status surrounding it have been written to a History Log if the History Logs were not already full. This event was also written to the Event Log, if so configured.

INPUT 2 OVERVOLTAGE

Input 2 Overvoltage

Source 2 is over voltage.

Contact technical support; in the United States, call 1-800-LIEBERT (1-800-543-2378). Outside the 48 contiguous United States contact Liebert Services, if available in your area. For international areas not covered by Liebert Services, the Liebert authorized distributor can provide technical support.

Press SILENCE on the touch screen to turn off the audible alarm, if so configured. If you are accessing the Liebert STS2/PDU system from a terminal, type **SH** and press RETURN on your keyboard to turn off the audible alarm.

This event and the system status surrounding it have been written to a History Log if the History Logs were not already full. This event was also written to the Event Log, if so configured.

INPUT 2 UNDERVOLTAGE

Input 2 Undervoltage

Source 2 is under voltage.

Contact technical support; in the United States, call 1-800-LIEBERT (1-800-543-2378). Outside the 48 contiguous United States contact Liebert Services, if available in your area. For international areas not covered by Liebert Services, the Liebert authorized distributor can provide technical support.

Press SILENCE on the touch screen to turn off the audible alarm, if so configured. If you are accessing the Liebert STS2/PDU system from a terminal, type **SH** and press RETURN on your keyboard to turn off the audible alarm.

This event and the system status surrounding it have been written to a History Log if the History Logs were not already full. This event was also written to the Event Log, if so configured.

LOAD OVERCURRENT

Load Overcurrent

Output is over current.

Contact technical support; in the United States, call 1-800-LIEBERT (1-800-543-2378). Outside the 48 contiguous United States contact Liebert Services, if available in your area. For international areas not covered by Liebert Services, the Liebert authorized distributor can provide technical support.

Press SILENCE on the touch screen to turn off the audible alarm, if so configured. If you are accessing the Liebert STS2/PDU system from a terminal, type **SH** and press RETURN on your keyboard to turn off the audible alarm.

This event and the system status surrounding it have been written to a History Log if the History Logs were not already full. This event was also written to the Event Log, if so configured.

GROUND OVERCURRENT

Ground Overcurrent

Ground is over current.

Contact technical support; in the United States, call 1-800-LIEBERT (1-800-543-2378). Outside the 48 contiguous United States contact Liebert Services, if available in your area. For international areas not covered by Liebert Services, the Liebert authorized distributor can provide technical support.

Press SILENCE on the touch screen to turn off the audible alarm, if so configured. If you are accessing the Liebert STS2/PDU system from a terminal, type **SH** and press RETURN on your keyboard to turn off the audible alarm.

This event and the system status surrounding it have been written to a History Log if the History Logs were not already full. This event was also written to the Event Log, if so configured.

NEUTRAL OVERCURRENT

Neutral Overcurrent

Neutral is over current.

Contact technical support; in the United States, call 1-800-LIEBERT (1-800-543-2378). Outside the 48 contiguous United States contact Liebert Services, if available in your area. For international areas not covered by Liebert Services, the Liebert authorized distributor can provide technical support.

Press SILENCE on the touch screen to turn off the audible alarm, if so configured. If you are accessing the Liebert STS2/PDU system from a terminal, type **SH** and press RETURN on your keyboard to turn off the audible alarm.

This event was also written to the Event Log, if so configured.

LOAD VOLTAGE THD

Load Voltage Total Harmonic Distortion

Voltage THD has exceeded the set limit.

Contact technical support; in the United States, call 1-800-LIEBERT (1-800-543-2378). Outside the 48 contiguous United States contact Liebert Services, if available in your area. For international areas not covered by Liebert Services, the Liebert authorized distributor can provide technical support.

Press SILENCE on the touch screen to turn off the audible alarm, if so configured. If you are accessing the Liebert STS2/PDU system from a terminal, type **SH** and press RETURN on your keyboard to turn off the audible alarm.

This event was also written to the Event Log, if so configured.

INPUT 1 CB6 OPEN

Input 1 CB6 Open

Source 1 input Circuit Breaker 6 is open.

Contact technical support; in the United States, call 1-800-LIEBERT (1-800-543-2378). Outside the 48 contiguous United States contact Liebert Services, if available in your area. For international areas not covered by Liebert Services, the Liebert authorized distributor can provide technical support.

Press SILENCE on the touch screen to turn off the audible alarm, if so configured. If you are accessing the Liebert STS2/PDU system from a terminal, type **SH** and press RETURN on your keyboard to turn off the audible alarm.

This event was also written to the Event Log, if so configured.

INPUT 2 CB7 OPEN

Input 2 CB7 Open

Source 2 Input Circuit Breaker 7 is open.

Contact technical support; in the United States, call 1-800-LIEBERT (1-800-543-2378). Outside the 48 contiguous United States contact Liebert Services, if available in your area. For international areas not covered by Liebert Services, the Liebert authorized distributor can provide technical support.

Press SILENCE on the touch screen to turn off the audible alarm, if so configured. If you are accessing the Liebert STS2/PDU system from a terminal, type **SH** and press RETURN on your keyboard to turn off the audible alarm.

This event was also written to the Event Log, if so configured.

INPUT 1 OF/UF

Input 1 Over Frequency/Under Frequency

Source 1 is over frequency/under frequency

Contact technical support; in the United States, call 1-800-LIEBERT (1-800-543-2378). Outside the 48 contiguous United States contact Liebert Services, if available in your area. For international areas not covered by Liebert Services, the Liebert authorized distributor can provide technical support.

Press SILENCE on the touch screen to turn off the audible alarm, if so configured. If you are accessing the Liebert STS2/PDU system from a terminal, type **SH** and press RETURN on your keyboard to turn off the audible alarm.

This event was also written to the Event Log, if so configured.

INPUT 2 OF/UF

Input 2 Over Frequency/Under Frequency

Source 2 is over frequency/under frequency.

Contact technical support; in the United States, call 1-800-LIEBERT (1-800-543-2378). Outside the 48 contiguous United States contact Liebert Services, if available in your area. For international areas not covered by Liebert Services, the Liebert authorized distributor can provide technical support.

Press SILENCE on the touch screen to turn off the audible alarm, if so configured. If you are accessing the Liebert STS2/PDU system from a terminal, type **SH** and press RETURN on your keyboard to turn off the audible alarm.

This event was also written to the Event Log, if so configured.

INPUT CONTACT #1

Input Contact Isolator #1

Occurrence of the indicated external event has been detected by Input Contact Isolator #1 of the Open Comms Digital Input option board.

Press SILENCE on the touch screen to turn off the audible alarm, if so configured. If you are accessing the Liebert STS2/PDU system from a terminal, type **SH** and press RETURN on your keyboard to turn off the audible alarm.

The event, with its assigned name, was written to the Event Log, if so configured.

The alarm has triggered a message to be sent to the modem, if so configured.

If configured to be a latching alarm, press RESET on the display. If you are accessing the unit from a terminal, type **CA** and press RETURN on your keyboard.

INPUT CONTACT #2

Input Contact Isolator #2

Occurrence of the indicated external event has been detected by Input Contact Isolator #2 of the Open Comms Digital Input option board.

Press SILENCE on the touch screen to turn off the audible alarm, if so configured. If you are accessing the Liebert STS2/PDU system from a terminal, type **SH** and press RETURN on your keyboard to turn off the audible alarm.

The event, with its assigned name, was written to the Event Log, if so configured.

The alarm has triggered a message to be sent to the modem, if so configured.

If configured to be a latching alarm, press RESET on the display. If you are accessing the unit from a terminal, type **CA** and press RETURN on your keyboard.

INPUT CONTACT #3

Input Contact Isolator #3

Occurrence of the indicated external event has been detected by Input Contact Isolator #3 of the Open Comms Digital Input option board.

Press SILENCE on the touch screen to turn off the audible alarm, if so configured. If you are accessing the Liebert STS2/PDU system from a terminal, type **SH** and press RETURN on your keyboard to turn off the audible alarm.

The event, with its assigned name, was written to the Event Log, if so configured.

The alarm has triggered a message to be sent to the modem, if so configured.

If configured to be a latching alarm, press RESET on the display. If you are accessing the unit from a terminal, type **CA** and press RETURN on your keyboard.

INPUT CONTACT #4

Input Contact Isolator #4

Occurrence of the indicated external event has been detected by Input Contact Isolator #4 of the Open Comms Digital Input option board.

Press SILENCE on the touch screen to turn off the audible alarm, if so configured. If you are accessing the Liebert STS2/PDU system from a terminal, type **SH** and press RETURN on your keyboard to turn off the audible alarm.

The event, with its assigned name, was written to the Event Log, if so configured.

The alarm has triggered a message to be sent to the modem, if so configured.

If configured to be a latching alarm, press RESET on the display. If you are accessing the unit from a terminal, type **CA** and press RETURN on your keyboard.

INPUT CONTACT #5

Input Contact Isolator #5

Occurrence of the indicated external event has been detected by Input Contact Isolator #5 of the Open Comms Digital Input option board.

Press SILENCE on the touch screen to turn off the audible alarm, if so configured. If you are accessing the Liebert STS2/PDU system from a terminal, type **SH** and press RETURN on your keyboard to turn off the audible alarm.

The event, with its assigned name, was written to the Event Log, if so configured.

The alarm has triggered a message to be sent to the modem, if so configured.

If configured to be a latching alarm, press RESET on the display. If you are accessing the unit from a terminal, type **CA** and press RETURN on your keyboard.

INPUT CONTACT #6

Input Contact Isolator #6

Occurrence of the indicated external event has been detected by Input Contact Isolator #6 of the Open Comms Digital Input option board.

Press SILENCE on the touch screen to turn off the audible alarm, if so configured. If you are accessing the Liebert STS2/PDU system from a terminal, type **SH** and press RETURN on your keyboard to turn off the audible alarm.

The event, with its assigned name, was written to the Event Log, if so configured.

The alarm has triggered a message to be sent to the modem, if so configured.

If configured to be a latching alarm, press RESET on the display. If you are accessing the unit from a terminal, type **CA** and press RETURN on your keyboard.

INPUT CONTACT #7

Input Contact Isolator #7

Occurrence of the indicated external event has been detected by Input Contact Isolator #7 of the Open Comms Digital Input option board.

Press SILENCE on the touch screen to turn off the audible alarm, if so configured. If you are accessing the Liebert STS2/PDU system from a terminal, type **SH** and press RETURN on your keyboard to turn off the audible alarm.

The event, with its assigned name, was written to the Event Log, if so configured.

The alarm has triggered a message to be sent to the modem, if so configured.

If configured to be a latching alarm, press RESET on the display. If you are accessing the unit from a terminal, type **CA** and press RETURN on your keyboard.

INPUT CONTACT #8

Input Contact Isolator #8

Occurrence of the indicated external event has been detected by Input Contact Isolator #8 of the Open Comms Digital Input option board.

Press SILENCE on the touch screen to turn off the audible alarm, if so configured. If you are accessing the Liebert STS2/PDU system from a terminal, type **SH** and press RETURN on your keyboard to turn off the audible alarm.

The event, with its assigned name, was written to the Event Log, if so configured.

The alarm has triggered a message to be sent to the modem, if so configured.

If configured to be a latching alarm, press RESET on the display. If you are accessing the unit from a terminal, type **CA** and press RETURN on your keyboard.

CONFIG MODIFIED

Configuration Modified

A setpoint has been updated and saved.

The event was written to the Event Log, if so configured.

PASSWORD CHANGED

Access Password Changed

The password for accessing the HMI (touch screen) options has been updated and saved.

The event was written to the Event Log, if so configured.

TIME REPROGRAMMED

System Time Reprogrammed

The system's time setting has been updated and saved.

The event was written to the Event Log, if so configured.

DATE REPROGRAMMED

System Date Reprogrammed

The system's date setting has been updated and saved.

The event was written to the Event Log, if so configured.

EVENT LOG CLEARED

Event Log Cleared

All past alarms and faults are no longer recorded in the system's event log.

This event was written to the Event Log, if so configured.

HIST LOGS CLEARED

History Logs Cleared

Both History Logs have been erased and the logs are now available to record future events.

The event was written to the Event Log, if so configured.

TRANSFER COUNTER CLEARED

Transfer Counter Cleared

Transfer counter reset to 0

Contact technical support; in the United States, call 1-800-LIEBERT (1-800-543-2378). Outside the 48 contiguous United States contact Liebert Services, if available in your area. For international areas not covered by Liebert Services, the Liebert authorized distributor can provide technical support.

This event was also written to the Event Log, if so configured.

KW-HRS COUNTER CLEARED

KW-HRS counter cleared

KW-Hrs counter reset to 0

Contact technical support; in the United States, call 1-800-LIEBERT (1-800-543-2378). Outside the 48 contiguous United States contact Liebert Services, if available in your area. For international areas not covered by Liebert Services, the Liebert authorized distributor can provide technical support.

This event was also written to the Event Log, if so configured.

16.0 MAINTENANCE



WARNING

Risk of electric shock. Can cause injury or death.

Only properly trained and qualified service personnel should perform maintenance on the Liebert STS2/PDU.

Lethal voltages exist inside the unit during normal operation.

The unit is supplied by multiple AC power sources. Disconnect and lock out all power sources before working inside unit.

Minimal periodic maintenance of the Liebert STS2/PDU is required. As with all electrical distribution components, the system should be regularly inspected for electrical connection integrity, signs of excessive temperatures, dirt accumulation and proper system operation.

16.1 Proper Tightening of Nuts and Bolts

The recommended tightening torque for all nuts and bolts is as shown below, unless otherwise labeled. All power connections are designed to remain at proper torque throughout the lifetime of the unit.

Table 28 Torque tightening

Bolt Shaft Size	Grade 5 - Imperial Grade 8.8 - Metric		Electrical Connections with Belleville Washers	
	in-lb (pound-inch)	N-m (Newton-meter)	in-lb (pound-inch)	N-m (Newton-meter)
10-32	25	3	35	4
1/4-20	53	6	80	9.0
5/16-18	107	12	180	20.4
3/8-16	192	22	240	27.1
1/2-13	428	48	480	54.3

Table 29 Branch circuit breakers

Current Rating	in-lb (pound-inch)	N-m (Newton-meter)
Up to 30 Amp	35	4.0
40 to 100 Amp	45	5.1

16.2 Testing the Liebert STS2/PDU

The Liebert STS2/PDU includes comprehensive system alarms and fault detection to identify operational problems. To increase the degree of confidence of proper system operation, periodic transfer tests can be easily performed. For instructions for changing the preferred source and switching sources, see **10.2 - Manual Transfer / Preferred Source Selection**.

16.3 Changing the Air Filter

A standard furnace filter is installed behind the air intake in the front door. The air intake allows air to circulate to cool the unit. Replace the filter when it becomes dirty and impedes air flow. The frequency of changing or cleaning the filter depends on the location in which the unit is located. The size of the filter is 1 x 25 x 25 in. (254 x 635 x 635mm).

17.0 CUSTOMER SETTINGS

17.1 Programmable Relay Board Settings

The optional programmable relay board (PRB) has eight channels to report events to an external device. Up to ten (10) events can be programmed to each channel. See **6.1 - Programmable Relay Board** for more information on the PRB.

If your Liebert STS2/PDU has the PRB option installed, list the settings below for future reference. If control power is lost in the Liebert STS2/PDU, the settings are not saved.

Table 30 Programmable relay board settings record

Channel 1

Channel 2

Channel 3

Channel 4

Channel 5

Channel 6

Table 30 Programmable relay board settings record (continued)

Channel 7

Channel 8

Channel 9

Channel 10

PRB Notes

17.2 Input Contact Isolator Settings

The Input Contact Isolator board (ICI) provides a Liebert STS2/PDU module interface for up to eight external user alarm or message inputs to be routed through the Liebert STS2/PDU's alarm network. See **6.2 - Input Contact Isolator Board** for more information on the ICI.

If your Liebert STS2/PDU has the ICI option installed, list the settings below for future reference. If control power is lost in the Liebert STS2/PDU, the settings are not saved.

Table 31 Input contact isolator settings record

Channel 1	_____
Channel 2	_____
Channel 3	_____
Channel 4	_____
Channel 5	_____
Channel 6	_____
Channel 7	_____
Channel 8	_____

Ensuring The High Availability Of Mission-Critical Data And Applications.

Emerson Network Power, the global leader in enabling business-critical continuity, ensures network resiliency and adaptability through a family of technologies—including Liebert power and cooling technologies—that protect and support business-critical systems. Liebert solutions employ an adaptive architecture that responds to changes in criticality, density and capacity. Enterprises benefit from greater IT system availability, operational flexibility and reduced capital equipment and operating costs.

Technical Support / Service Web Site

www.liebert.com

Monitoring

800-222-5877

monitoring@emersonnetworkpower.com

Outside the US: 614-841-6755

Single-Phase UPS

800-222-5877

upstech@emersonnetworkpower.com

Outside the US: 614-841-6755

Three-Phase UPS

800-543-2378

powertech@emersonnetworkpower.com

Environmental Systems

800-543-2778

Outside the United States

614-888-0246

Locations

United States

1050 Dearborn Drive

P.O. Box 29186

Columbus, OH 43229

Europe

Via Leonardo Da Vinci 8

Zona Industriale Tognana

35028 Piove Di Sacco (PD) Italy

+39 049 9719 111

Fax: +39 049 5841 257

Asia

7/F, Dah Sing Financial Centre

108 Gloucester Road, Wanchai

Hong Kong

852 2572220

Fax: 852 28029250

While every precaution has been taken to ensure the accuracy and completeness of this literature, Liebert Corporation assumes no responsibility and disclaims all liability for damages resulting from use of this information or for any errors or omissions.

© 2007 Liebert Corporation

All rights reserved throughout the world. Specifications subject to change without notice.

® Liebert is a registered trademark of Liebert Corporation.

All names referred to are trademarks

or registered trademarks of their respective owners.

SL-20730_REV03_03-08

Emerson Network Power.

The global leader in enabling *Business-Critical Continuity*.

■ AC Power

■ Embedded Computing

■ Outside Plant

■ Racks & Integrated Cabinets

■ Connectivity

■ Embedded Power

■ Power Switching & Controls

■ Services

■ DC Power

■ Monitoring

■ Precision Cooling

■ Surge Protection

EmersonNetworkPower.com

Business-Critical Continuity, Emerson Network Power and the Emerson Network Power logo are trademarks and service marks of Emerson Electric Co.

©2007 Emerson Electric Co.